

- Package Options Include Plastic and Ceramic DIPs and Ceramic Flat Packages
- Dependable Texas Instruments Quality and Reliability

SN54128 . . . J OR W PACKAGE  
SN74128 . . . N PACKAGE  
(TOP VIEW)

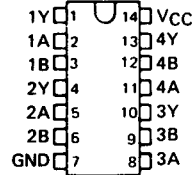

### description

These devices contain four independent 2-input-NOR line drivers. They perform the Boolean function  $Y = A + B$  or  $Y = \bar{A} \cdot \bar{B}$ . The SN54128 is designed to drive 75 ohm lines. The SN74128 is designed to drive 50 ohm lines.

The SN54128 is characterized for operation over the full military temperature range of  $-55^{\circ}\text{C}$  to  $125^{\circ}\text{C}$ . The SN74128 is characterized for operation from  $0^{\circ}\text{C}$  to  $70^{\circ}\text{C}$ .

### logic diagram (each driver)



### logic symbol†

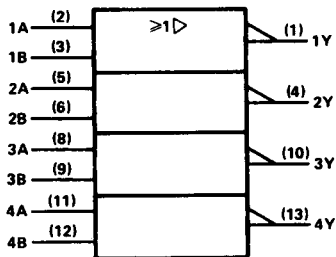

†This symbol is in accordance with ANSI/IEEE Std 91-1984 and IEC Publication 617-12.

### schematic (each driver)

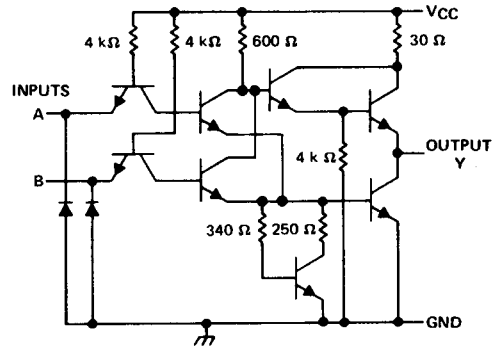

Resistor values shown are nominal.

2  
TTL Devices

### absolute maximum ratings over operating free-air temperature range (unless otherwise noted)

Supply voltage, $V_{CC}$ (see Note 1)	7 V
Input voltage	5.5 V
Operating free-air temperature range: SN54'	$-55^{\circ}\text{C}$ to $125^{\circ}\text{C}$
SN74'	$0^{\circ}\text{C}$ to $70^{\circ}\text{C}$
Storage temperature range	$-65^{\circ}\text{C}$ to $150^{\circ}\text{C}$

NOTE 1: Voltage values are with respect to network ground terminal.

**SN54128, SN74128**  
**LINE DRIVERS**

**recommended operating conditions**

	SN54128			SN74128			UNIT
	MIN	NOM	MAX	MIN	NOM	MAX	
V <sub>CC</sub> Supply voltage	4.5	5	5.5	4.75	5	5.25	V
V <sub>IH</sub> High-level input voltage	2			2			V
V <sub>IL</sub> Low-level input voltage	0.8			0.8			V
I <sub>OH</sub> High-level output current	-29			-42.4			mA
I <sub>OL</sub> Low-level output current	48			48			mA
T <sub>A</sub> Operating free-air temperature	-55			0			70 °C

**electrical characteristics over recommended operating free-air temperature range (unless otherwise noted)**

PARAMETER	TEST CONDITIONS †	MIN	TYP ‡	MAX	UNIT
V <sub>IK</sub>	V <sub>CC</sub> = MIN, I <sub>I</sub> = -12 mA			-1.5	V
V <sub>OH</sub>	V <sub>CC</sub> = MIN, V <sub>IL</sub> = 0.8 V, I <sub>OH</sub> = -2.4 mA	2.4	3.4		V
	V <sub>CC</sub> = MIN, V <sub>IL</sub> = 0.4 V, I <sub>OH</sub> = -13.2 mA	2.4			
	V <sub>CC</sub> = MIN, V <sub>IL</sub> = 0.4 V, I <sub>OH</sub> = MAX	2			
V <sub>OL</sub>	V <sub>CC</sub> = MIN, V <sub>IH</sub> = 2 V, I <sub>OL</sub> = 48 mA		0.26	0.4	V
I <sub>I</sub>	V <sub>CC</sub> = MAX, V <sub>I</sub> = 5.5 V			1	mA
I <sub>IH</sub>	V <sub>CC</sub> = MAX, V <sub>I</sub> = 2.4 V			40	μA
I <sub>IL</sub>	V <sub>CC</sub> = MAX, V <sub>I</sub> = 0.4 V			-1.6	mA
I <sub>OS</sub> §	V <sub>CC</sub> = MAX	-70		-180	mA
I <sub>CCH</sub>	V <sub>CC</sub> = MAX		12	21	mA
I <sub>CCL</sub>	V <sub>CC</sub> = MAX		33	57	mA

† For conditions shown as MIN or MAX, use the appropriate value specified under recommended operating conditions.

‡ All typical values are at V<sub>CC</sub> = 5 V, T<sub>A</sub> = 25° C.

§ Not more than one output should be shorted at a time.

**switching characteristics, V<sub>CC</sub> = 5 V, T<sub>A</sub> = 25° C (see note 2)**

PARAMETER	FROM (INPUT)	TO (OUTPUT)	TEST CONDITIONS	MIN	TYP	MAX	UNIT
t <sub>PLH</sub>	A or B	Y	R <sub>L</sub> = 133 Ω, C <sub>L</sub> = 50 pF	6	9	ns	
t <sub>PHL</sub>				8	12	ns	
t <sub>PLH</sub>			R <sub>L</sub> = 133 Ω, C <sub>L</sub> = 150 pF	10	15	ns	
t <sub>PHL</sub>				12	18	ns	

NOTE 2: Load circuits and voltage waveforms are shown in Section 1.

**2 TTL Devices**