



QUAD 2-INPUT NAND GATE

DESCRIPTION

The T54LS01/T74LS01 is a high speed QUAD 2-INPUT NAND GATE (with open collector output) fabricated in LOW POWER SCHOTTKY technology.

B1
Plastic Package

D1/D2
Ceramic Package

M1
Micro Package

C1
Plastic Chip Carrier

ORDERING NUMBERS:
 T54LS01 D2 T74LS01 C1
 T74LS01 D1 T74LS01 M1
 T74LS01 B1

PIN CONNECTION (top view)

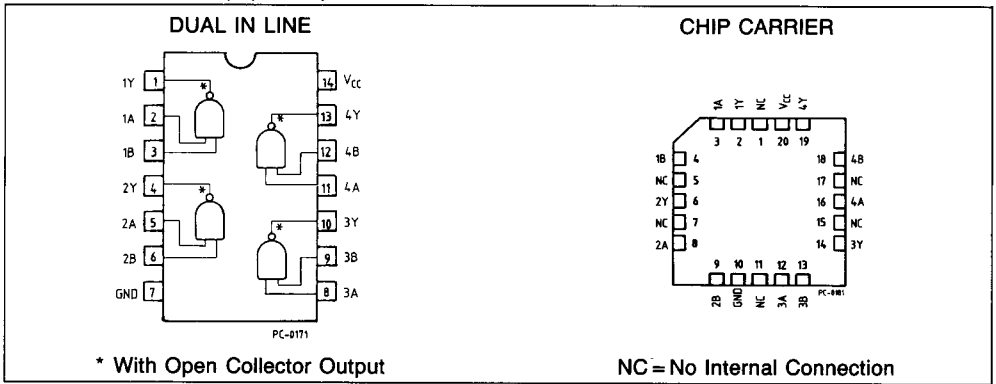

SCHEMATIC

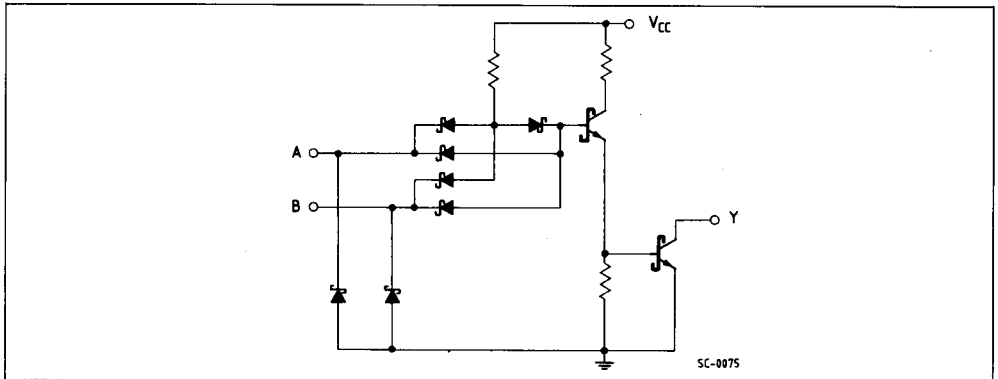



LOGIC DIAGRAM AND TRUTH TABLE



A	B	Y
L	X	H
X	L	H
H	H	L

L = LOW Voltage level
H = HIGH Voltage Level
X = Don't Care

ABSOLUTE MAXIMUM RATINGS

Symbol	Parameter	Value	Unit
V_{CC}	Supply Voltage	-0.5 to 7	V
V_I	Input Voltage, Applied to Input	-0.5 to 15	V
V_O	Output Voltage, Applied to Output	0 to 10	V
I_I	Input Current, Into Inputs	-30 to 5	mA
I_O	Output Current, Into Outputs	50	mA

Stresses in excess of those listed under "Absolute Maximum Ratings" may cause permanent damage to the device. This is a stress rating only and functional operation of the device at these or any other conditions in excess of those indicated in the operational sections of this specification is not implied. Exposure to absolute maximum rating conditions for extended periods may affect device reliability.

GUARANTEED OPERATING RANGES

Part Numbers	Supply Voltage			Temperature
	Min	Typ	Max	
T54LS01D2	4.5 V	5.0 V	5.5 V	-55°C to +125°C
T74LS01XX	4.75 V	5.0 V	5.25 V	0°C to +70°C

XX = package type.

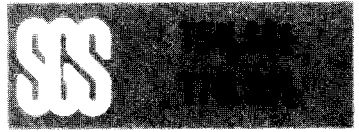

DC CHARACTERISTICS OVER OPERATING TEMPERATURE RANGE

Symbol	Parameter		Limits			Test Conditions (Note 1)		Units
			Min.	Typ.	Max.			
V _{IH}	Input HIGH Voltage		2.0			Guaranteed input HIGH Voltage for all Inputs		V
V _{IL}	Input LOW Voltage	54		0.7	Guaranteed input LOW Voltage for all Inputs		V	
		74		0.8				
V _{CD}	Input Clamp Diode Voltage			-0.65	-1.5	V _{CC} = MIN, I _{IN} = -18mA		V
I _{OH}	Output HIGH Current	54,74			100	V _{CC} = MIN, V _{OH} = 5.5mA		μA
V _{OL}	Output LOW Voltage	54,74		0.25	0.4	I _{OL} = 4.0mA V _{CC} = MIN, V _{IN} = V _{IH} or V _{IL} per Truth Table	V	
		74		0.35	0.5			I _{OL} = 8.0mA
I _{IH}	Input HIGH Current				20 0.1	V _{CC} = MAX, V _{IN} = 2.7V V _{CC} = MAX, V _{IN} = 7.0V		μA mA
I _{IL}	Input LOW Current				-0.4	V _{CC} = MAX, V _{IN} = 0.4V		mA
I _{CC}	Power Supply Current Total, Output HIGH Total, Output LOW				1.6 4.4	V _{CC} = MAX		mA

AC CHARACTERISTICS: T_A = 25°C (See page 576 for AC test circuit and waveforms)

Symbol	Parameter		Limits			Test Conditions		Units
			Min.	Typ.	Max.			
t _{PLH}	Turn Off Delay, Input to Output			17	32	V _{CC} = 5.0V C _L = 15pF, R _L = 2.0 kΩ		ns
t _{PHL}	Turn On Delay, Input to Output			15	28			ns

Notes:

- 1) For conditions shown as MIN or MAX, use the appropriate value specified under guaranteed operating ranges.
- 2) Typical values are at V_{CC} = 5.0V, T_A = 25°C