

DATA SHEET

74ABT377A

Octal D-type flip-flop with enable

Product specification
Replaces data sheet 74ABT377 of 1995 Sep 06
IC23 Data Handbook

1997 Feb 26

Octal D-type flip-flop with enable

74ABT377A

FEATURES

- Ideal for addressable register applications
- 8-bit positive edge-triggered register
- Enable for address and data synchronization applications
- Output capability: +64mA/-32mA
- Latch-up protection exceeds 500mA per Jedec JC40.2 Std 17
- ESD protection exceeds 2000V per MIL STD 883 Method 3015 and 200V per Machine Model
- Power-up reset

DESCRIPTION

The 74ABT377A high-performance BiCMOS device combines low static and dynamic power dissipation with high speed and high output drive.

The 74ABT377A has 8 edge-triggered D-type flip-flops with individual D inputs and Q outputs. The common buffered clock (CP) input loads all flip-flops simultaneously when the Enable (E) input is Low.

The register is fully edge triggered. The state of each D input, one set-up time before the Low-to-High clock transition, is transferred to the corresponding flip-flop's Q output.

The E input must be stable one setup time prior to the Low-to-High clock transition for predictable operation.

QUICK REFERENCE DATA

SYMBOL	PARAMETER	CONDITIONS $T_{amb} = 25^{\circ}\text{C}; \text{GND} = 0\text{V}$	TYPICAL	UNIT
t_{PLH} t_{PHL}	Propagation delay CP to Qn	$C_L = 50\text{pF}; V_{CC} = 5\text{V}$	3.1 3.6	ns
C_{IN}	Input capacitance	$V_I = 0\text{V or } V_{CC}$	4	pF
I_{CCH}	Total current supply	Outputs High; $V_{CC} = 5.5\text{V}$	500	nA

ORDERING INFORMATION

PACKAGES	TEMPERATURE RANGE	OUTSIDE NORTH AMERICA	NORTH AMERICA	DWG NUMBER
20-Pin Plastic DIP	-40°C to +85°C	74ABT377A N	74ABT377A N	SOT146-1
20-Pin plastic SO	-40°C to +85°C	74ABT377A D	74ABT377A D	SOT163-1
20-Pin Plastic SSOP Type II	-40°C to +85°C	74ABT377A DB	74ABT377A DB	SOT339-1
20-Pin Plastic TSSOP Type I	-40°C to +85°C	74ABT377A PW	74ABT377PWA DH	SOT360-1

PIN CONFIGURATION

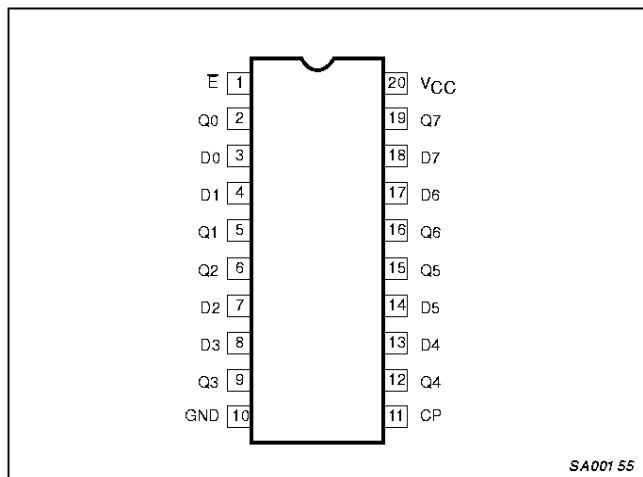

LOGIC SYMBOL

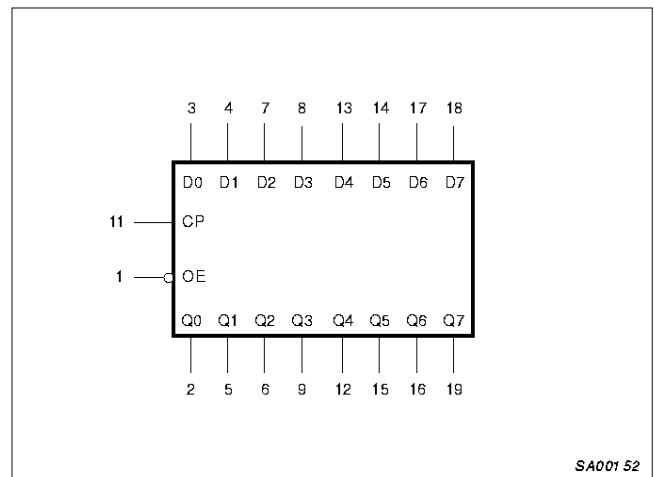

Octal D-type flip-flop with enable

74ABT377A

LOGIC SYMBOL (IEEE/IEC)

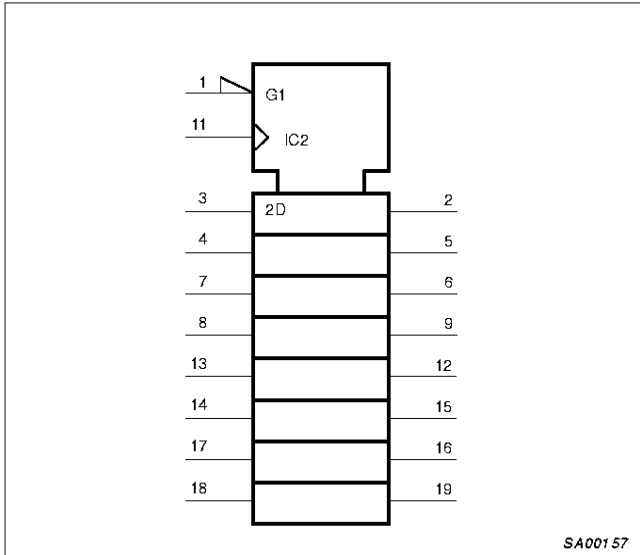

PIN DESCRIPTION

PIN NUMBER	SYMBOL	FUNCTION
1	E	Enable input (active-Low)
3, 4, 7, 8, 13, 14, 17, 18	D0-D7	Data inputs
2, 5, 6, 9, 12, 15, 16, 19	Q0-Q7	Data outputs
11	CP	Clock Pulse input (active rising edge)
10	GND	Ground (0V)
20	V _{CC}	Positive supply voltage

LOGIC DIAGRAM

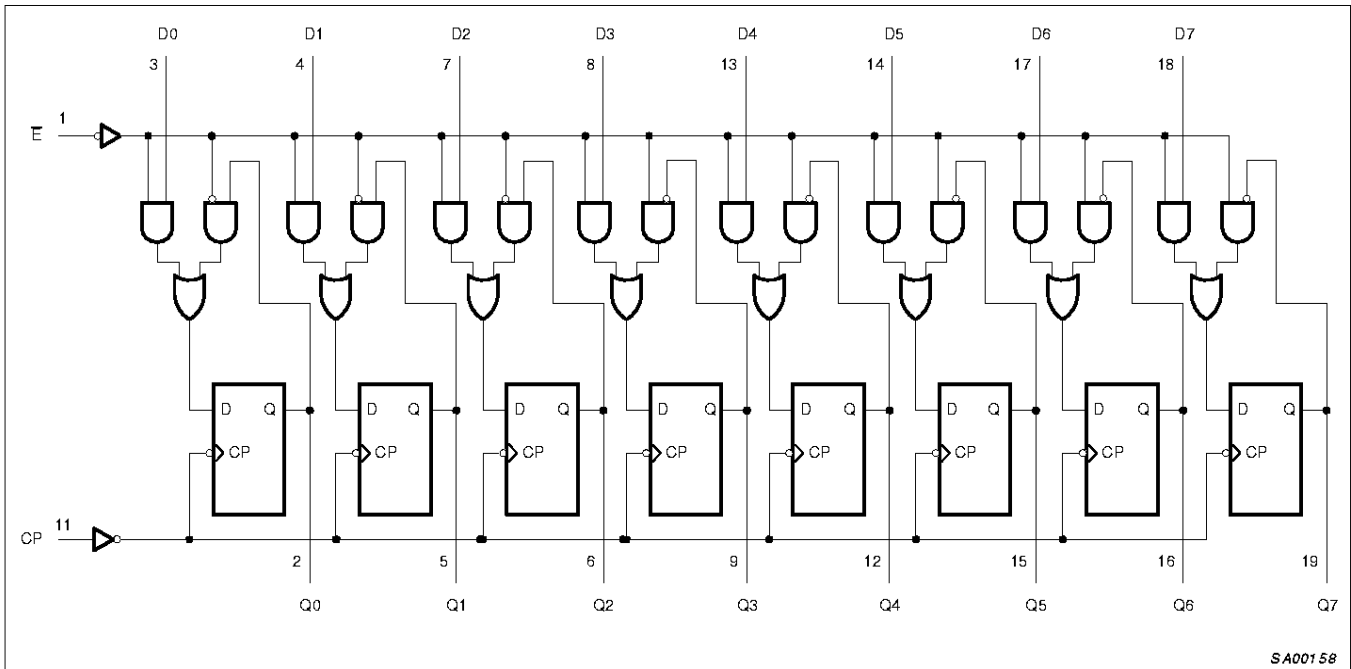

Octal D-type flip-flop with enable

74ABT377A

FUNCTION TABLE

INPUTS			OUTPUTS	OPERATING MODE
\bar{E}	CP	Dn	Qn	
l	↑	h	H	Load "1"
l	↑	l	L	Load "0"
h H	↑ X	X X	no change no change	Hold (do nothing)

H = High voltage level

h = High voltage level one set-up time prior to the Low-to-High clock transition

L = Low voltage level

l = Low voltage level one set-up time prior to the Low-to-High clock transition

X = Don't care

↑ = Low-to-High clock transition

ABSOLUTE MAXIMUM RATINGS^{1, 2}

SYMBOL	PARAMETER	CONDITIONS	RATING	UNIT
V _{CC}	DC supply voltage		-0.5 to +7.0	V
I _{IK}	DC input diode current	V _I < 0	-18	mA
V _I	DC input voltage ³		-1.2 to +7.0	V
I _{OK}	DC output diode current	V _O < 0	-50	mA
V _{OUT}	DC output voltage ³	output in Off or High state	-0.5 to +5.5	V
I _{OUT}	DC output current	output in Low state	128	mA
T _{stg}	Storage temperature range		-65 to 150	°C

NOTES:

- Stresses beyond those listed may cause permanent damage to the device. These are stress ratings only and functional operation of the device at these or any other conditions beyond those indicated under "recommended operating conditions" is not implied. Exposure to absolute-maximum-rated conditions for extended periods may affect device reliability.
- The performance capability of a high-performance integrated circuit in conjunction with its thermal environment can create junction temperatures which are detrimental to reliability. The maximum junction temperature of this integrated circuit should not exceed 150°C.
- The input and output voltage ratings may be exceeded if the input and output current ratings are observed.

RECOMMENDED OPERATING CONDITIONS

SYMBOL	PARAMETER	LIMITS		UNIT
		MIN	MAX	
V _{CC}	DC supply voltage	4.5	5.5	V
V _I	Input voltage	0	V _{CC}	V
V _{IH}	High-level input voltage	2.0		V
V _{IL}	Low-level input voltage		0.8	V
I _{OH}	High-level output current		-32	mA
I _{OL}	Low-level output current		64	mA
Δt/Δv	Input transition rise or fall rate	0	5	ns/V
T _{amb}	Operating free-air temperature range	-40	+85	°C

Octal D-type flip-flop with enable

74ABT377A

DC ELECTRICAL CHARACTERISTICS

SYMBOL	PARAMETER	TEST CONDITIONS	LIMITS					UNIT
			T _{amb} = +25°C			T _{amb} = -40°C to +85°C		
			MIN	TYP	MAX	MIN	MAX	
V _{IK}	Input clamp voltage	V _{CC} = 4.5V; I _{IK} = -18mA		-0.9	-1.2		-1.2	V
V _{OH}	High-level output voltage	V _{CC} = 4.5V; I _{OH} = -3mA; V _I = V _{IL} or V _{IH}	2.5	2.9		2.5		V
		V _{CC} = 5.0V; I _{OH} = -3mA; V _I = V _{IL} or V _{IH}	3.0	3.4		3.0		V
		V _{CC} = 4.5V; I _{OH} = -32mA; V _I = V _{IL} or V _{IH}	2.0	2.4		2.0		V
V _{OL}	Low-level output voltage	V _{CC} = 4.5V; I _{OL} = 64mA; V _I = V _{IL} or V _{IH}		0.42	0.55		0.55	V
V _{RST}	Power-up output low voltage ³	V _{CC} = 5.5V; I _O = 1mA; V _I = GND or V _{CC}		0.13	0.55		0.55	V
I _I	Input leakage current	V _{CC} = 5.5V; V _I = GND or 5.5V		±0.01	±1.0		±1.0	µA
I _{OFF}	Power-off leakage current	V _{CC} = 0.0V; V _O or V _I ≤ 4.5V		±5.0	±100		±100	µA
I _{CEX}	Output High leakage current	V _{CC} = 5.5V; V _O = 5.5V; V _I = GND or V _{CC}		5.0	50		50	µA
I _O	Output current ¹	V _{CC} = 5.5V; V _O = 2.5V	-50	-100	-180	-50	-180	mA
I _{CCH}	Quiescent supply current	V _{CC} = 5.5V; Outputs High, V _I = GND or V _{CC}		0.5	250		250	µA
I _{CCL}		V _{CC} = 5.5V; Outputs Low, V _I = GND or V _{CC}		24	30		30	mA
ΔI _{CC}	Additional supply current per input pin ²	V _{CC} = 5.5V; one input at 3.4V, other inputs at V _{CC} or GND		0.5	1.5		1.5	mA

NOTES:

- Not more than one output should be tested at a time, and the duration of the test should not exceed one second.
- This is the increase in supply current for each input at 3.4V.
- For valid test results, data must not be loaded into the flip-flops (or latches) after applying the power.

AC CHARACTERISTICS

GND = 0V, t_R = t_F = 2.5ns, C_L = 50pF, R_L = 500Ω

SYMBOL	PARAMETER	WAVEFORM	LIMITS ¹					UNIT
			T _{amb} = +25°C V _{CC} = +5.0V			T _{amb} = -40 to +85°C V _{CC} = +5.0V ±0.5V		
			MIN	TYP	MAX	MIN	MAX	
f _{MAX}	Maximum clock frequency	1	150	250		150		MHz
t _{PLH} t _{PHL}	Propagation delay CP to Qn	1	1.8 2.2	3.1 3.6	4.0 4.7	1.8 2.2	4.8 4.9	ns

NOTE:

- Limits may vary among suppliers.

Octal D-type flip-flop with enable

74ABT377A

AC SETUP REQUIREMENTS

GND = 0V, $t_R = t_F = 2.5\text{ns}$, $C_L = 50\text{pF}$, $R_L = 500\Omega$

SYMBOL	PARAMETER	WAVEFORM	LIMITS			UNIT
			$T_{amb} = +25^\circ\text{C}$ $V_{CC} = +5.0\text{V}$		$T_{amb} = -40 \text{ to } +85^\circ\text{C}$ $V_{CC} = +5.0\text{V} \pm 0.5\text{V}$	
			MIN	TYP	MIN	
$t_{s(H)}$ $t_{s(L)}$	Setup time, High or Low Dn to CP	2	1.5 1.5	0.7 0.5	1.5 1.5	ns
$t_{h(H)}$ $t_{h(L)}$	Hold time, High or Low Dn to CP	2	1.0 1.0	-0.4 -0.6	1.0 1.0	ns
$t_{s(H)}$ $t_{s(L)}$	Setup time, High or Low E to CP	2	2.0 2.0	1.1 1.0	2.0 2.0	ns
$t_{h(H)}$ $t_{h(L)}$	Hold time, High or Low E to CP	2	1.0 1.0	-0.9 -0.1	1.0 1.0	ns
$t_w(H)$ $t_w(L)$	Clock Pulse width High or Low	1	1.5 2.0	0.7 1.0	1.5 2.0	ns

AC WAVEFORMS

$V_M = 1.5\text{V}$, $V_{IN} = \text{GND to } 3.0\text{V}$

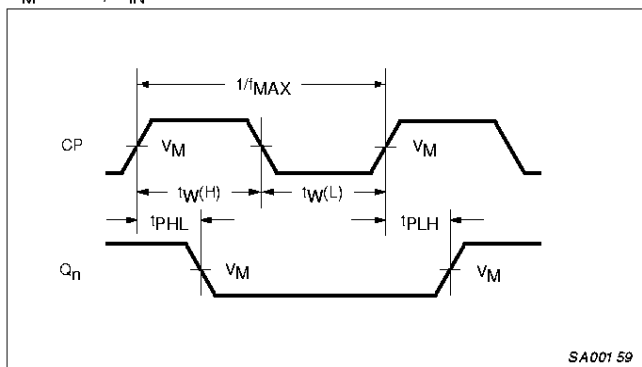

Waveform 1. Propagation Delay, Clock Input to Output, Clock Pulse Width and Maximum Clock Frequency

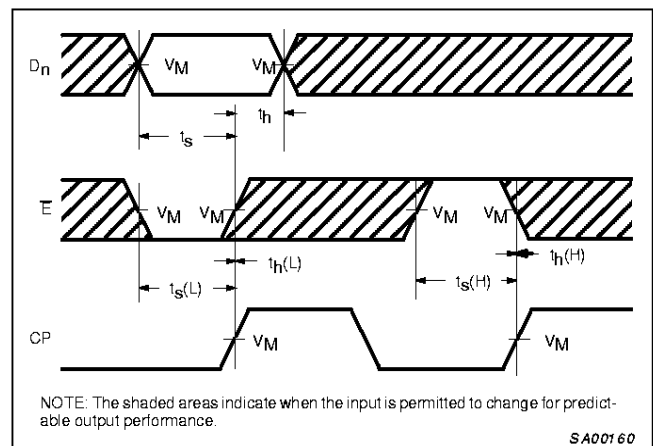

Waveform 2. Data and Enable Setup and Hold Times

Octal D-type flip-flop with enable

74ABT377A

TEST CIRCUIT AND WAVEFORM

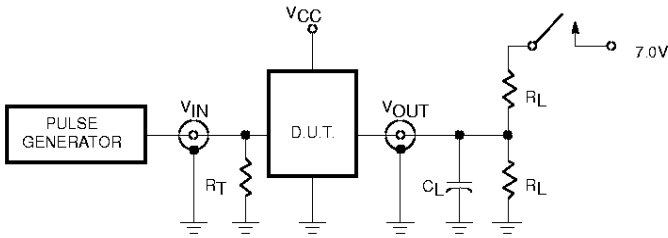

Test Circuit for 3-State Outputs

SWITCH POSITION

TEST	SWITCH
All	open

DEFINITIONS

- R_L = Load resistor; see AC CHARACTERISTICS for value.
- C_L = Load capacitance includes jig and probe capacitance; see AC CHARACTERISTICS for value.
- R_T = Termination resistance should be equal to Z_{OUT} of pulse generators.

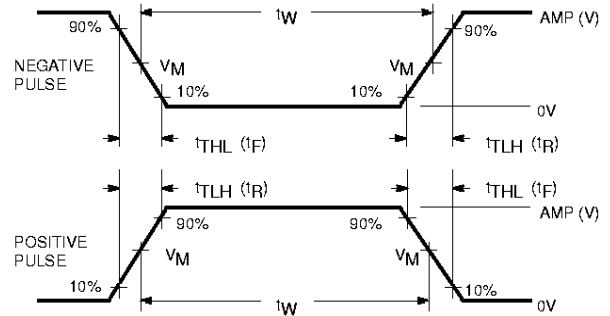

$V_M = 1.5V$

Input Pulse Definition

FAMILY	INPUT PULSE REQUIREMENTS				
	Amplitude	Rep. Rate	t_W	t_R	t_F
74ABT	3.0V	1MHz	500ns	2.5ns	2.5ns

SA00057

Octal D-type flip-flop with enable

74ABT377A

DIP20: plastic dual in-line package; 20 leads (300 mil)

SOT146-1

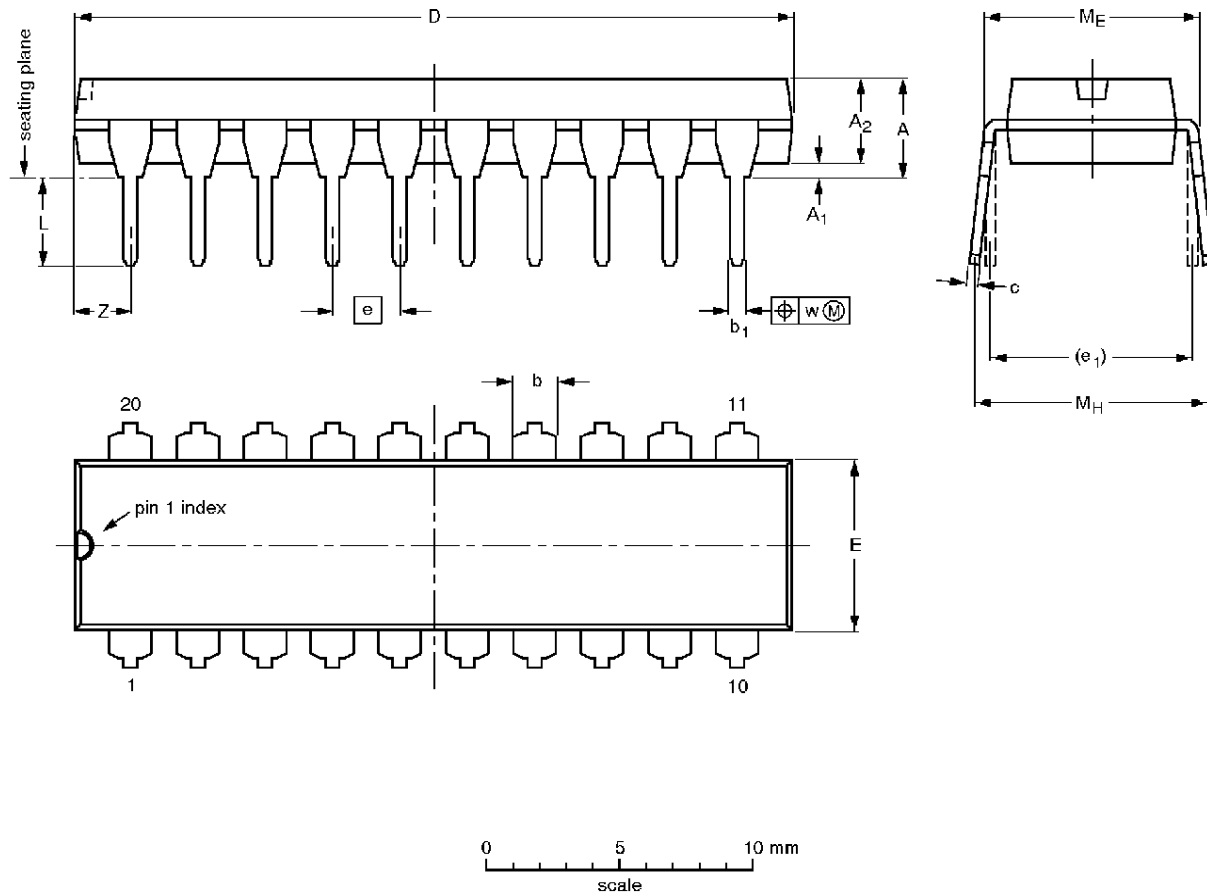

DIMENSIONS (inch dimensions are derived from the original mm dimensions)

UNIT	A max.	A ₁ min.	A ₂ max.	b	b ₁	c	D ⁽¹⁾	E ⁽¹⁾	e	e ₁	L	M _E	M _H	w	z ⁽¹⁾ max.
mm	4.2	0.51	3.2	1.73 1.30	0.53 0.38	0.36 0.23	26.92 26.54	6.40 6.22	2.54	7.62	3.60 3.05	8.25 7.80	10.0 8.3	0.254	2.0
inches	0.17	0.020	0.13	0.068 0.051	0.021 0.015	0.014 0.009	1.060 1.045	0.25 0.24	0.10	0.30	0.14 0.12	0.32 0.31	0.39 0.33	0.01	0.078

Note

1. Plastic or metal protrusions of 0.25 mm maximum per side are not included.

OUTLINE VERSION	REFERENCES				EUROPEAN PROJECTION	ISSUE DATE
	IEC	JEDEC	EIAJ			
SOT146-1			SC603			92-11-17 95-05-24

Octal D-type flip-flop with enable

74ABT377A

SO20: plastic small outline package; 20 leads; body width 7.5 mm

SOT163-1

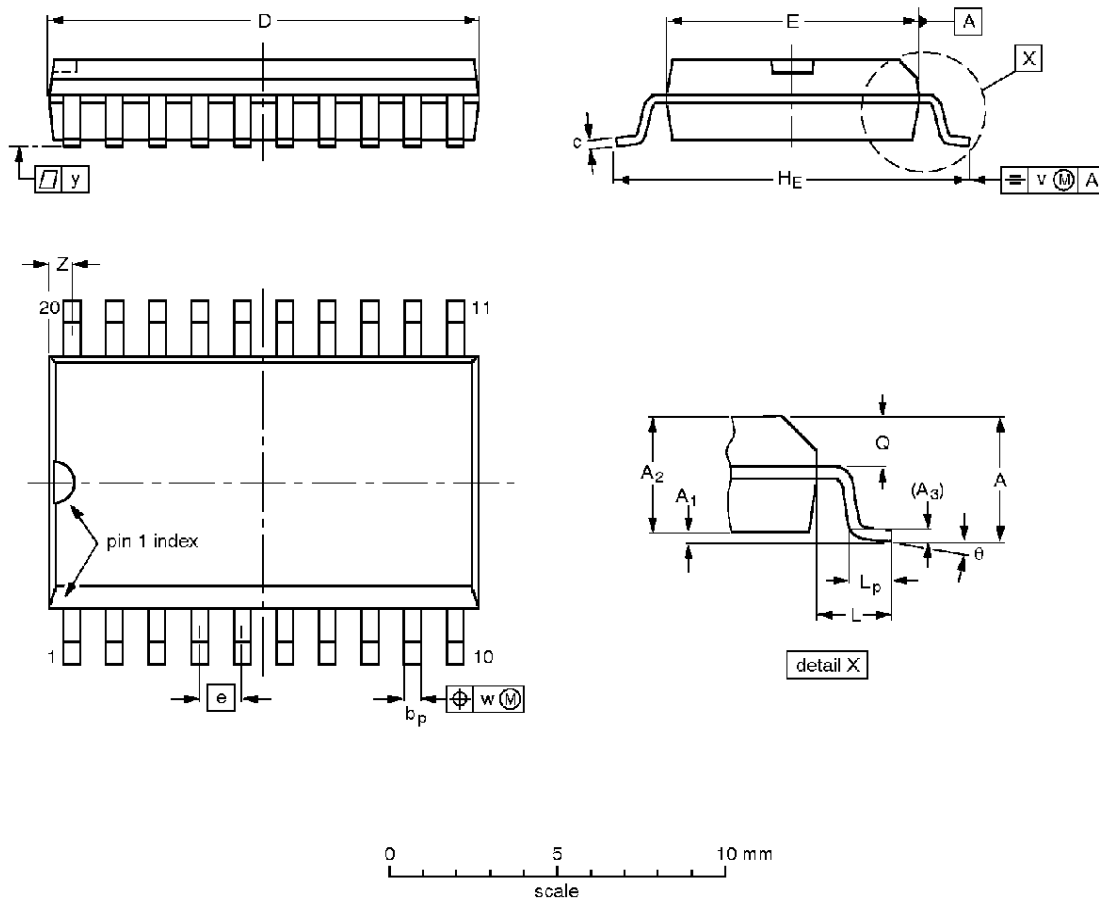

DIMENSIONS (inch dimensions are derived from the original mm dimensions)

UNIT	A max.	A ₁	A ₂	A ₃	b _p	c	D ⁽¹⁾	E ⁽¹⁾	e	H _E	L	L _p	Q	v	w	y	Z ⁽¹⁾	θ
mm	2.65	0.30 0.10	2.45 2.25	0.25	0.49 0.36	0.32 0.23	13.0 12.6	7.6 7.4	1.27	10.85 10.00	1.4	1.1 0.4	1.1 1.0	0.25	0.25	0.1	0.9 0.4	8° 0°
inches	0.10	0.012 0.004	0.096 0.089	0.01	0.019 0.014	0.013 0.009	0.51 0.49	0.30 0.29	0.050	0.42 0.39	0.055	0.043 0.016	0.043 0.039	0.01	0.01	0.004	0.035 0.016	

Note

1. Plastic or metal protrusions of 0.15 mm maximum per side are not included.

OUTLINE VERSION	REFERENCES				EUROPEAN PROJECTION	ISSUE DATE
	IEC	JEDEC	EIAJ			
SOT163-1	075E04	MS-013AC				92-11-17 95-01-24

Octal D-type flip-flop with enable

74ABT377A

SSOP20: plastic shrink small outline package; 20 leads; body width 5.3 mm

SOT339-1

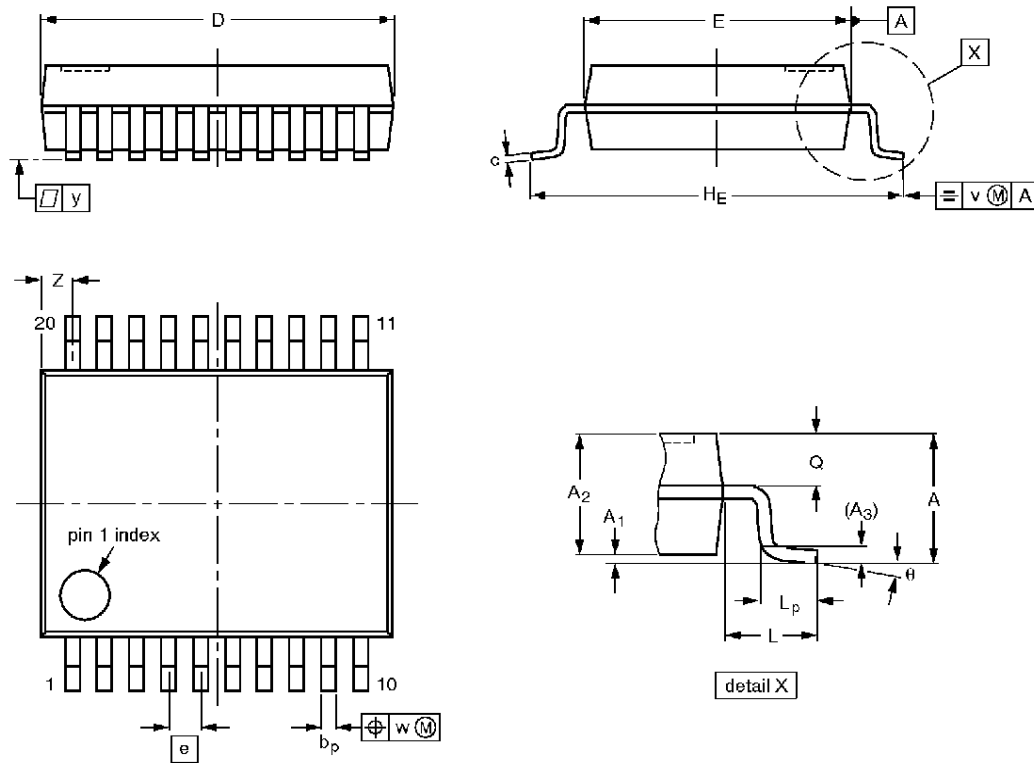

DIMENSIONS (mm are the original dimensions)

UNIT	A max.	A ₁	A ₂	A ₃	b _p	c	D ⁽¹⁾	E ⁽¹⁾	e	HE	L	L _p	Q	v	w	y	Z ⁽¹⁾	θ
mm	2.0	0.21 0.05	1.80 1.65	0.25	0.38 0.25	0.20 0.09	7.4 7.0	5.4 5.2	0.65	7.9 7.6	1.25	1.03 0.63	0.9 0.7	0.2	0.13	0.1	0.9 0.5	8° 0°

Note

1. Plastic or metal protrusions of 0.20 mm maximum per side are not included.

OUTLINE VERSION	REFERENCES				EUROPEAN PROJECTION	ISSUE DATE
	IEC	JEDEC	EIAJ			
SOT339-1		MO-150AE				93-09-08 95-02-04

Octal D-type flip-flop with enable

74ABT377A

TSSOP20: plastic thin shrink small outline package; 20 leads; body width 4.4 mm

SOT360-1

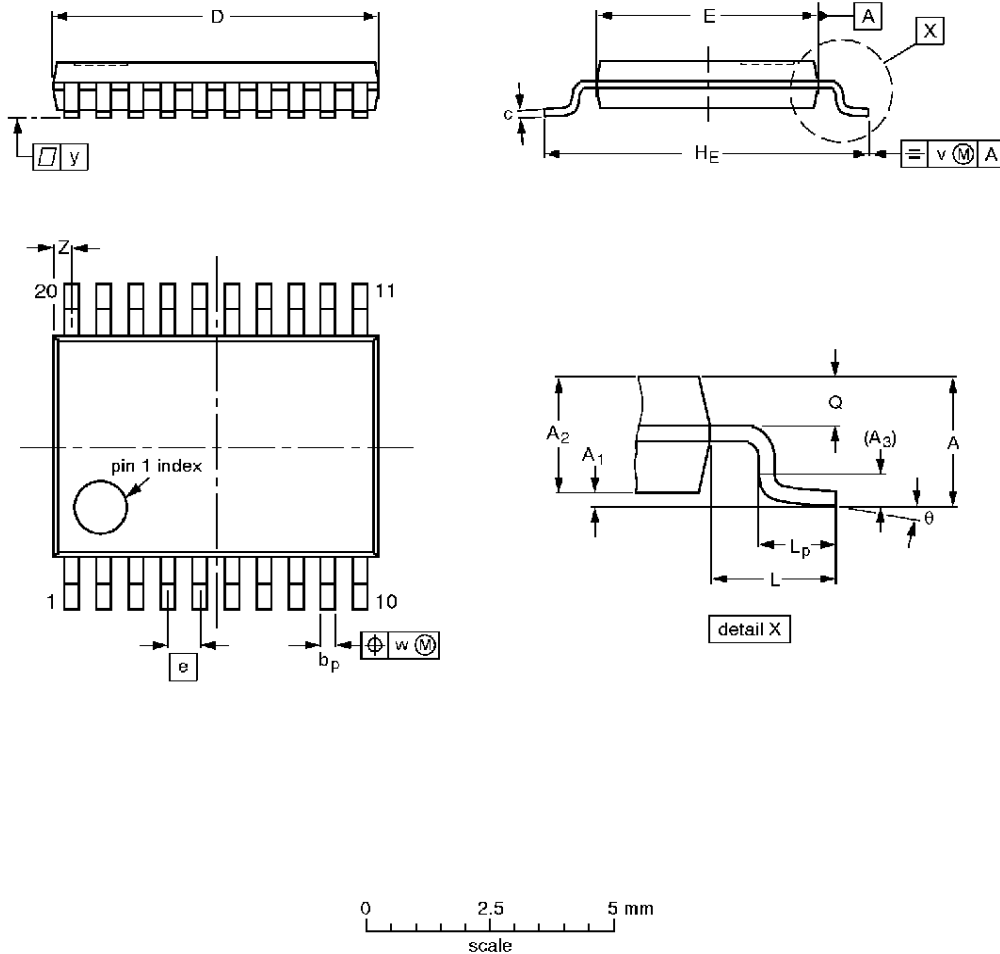

DIMENSIONS (mm are the original dimensions)

UNIT	A max.	A ₁	A ₂	A ₃	b _p	c	D ⁽¹⁾	E ⁽²⁾	e	H _E	L	L _p	Q	v	w	y	Z ⁽¹⁾	θ
mm	1.10	0.15 0.05	0.95 0.80	0.25	0.30 0.19	0.2 0.1	6.6 6.4	4.5 4.3	0.65	6.6 6.2	1.0	0.75 0.50	0.4 0.3	0.2	0.13	0.1	0.5 0.2	8° 0°

Notes

1. Plastic or metal protrusions of 0.15 mm maximum per side are not included.
2. Plastic interlead protrusions of 0.25 mm maximum per side are not included.

OUTLINE VERSION	REFERENCES				EUROPEAN PROJECTION	ISSUE DATE
	IEC	JEDEC	EIAJ			
SOT360-1		MO-153AC				-93-06-16 95-02-04

Octal D-type flip-flop with enable

74ABT377A

DEFINITIONS

Data Sheet Identification	Product Status	Definition
<i>Objective Specification</i>	Formative or In Design	This data sheet contains the design target or goal specifications for product development. Specifications may change in any manner without notice.
<i>Preliminary Specification</i>	Preproduction Product	This data sheet contains preliminary data, and supplementary data will be published at a later date. Philips Semiconductors reserves the right to make changes at any time without notice in order to improve design and supply the best possible product.
<i>Product Specification</i>	Full Production	This data sheet contains Final Specifications. Philips Semiconductors reserves the right to make changes at any time without notice, in order to improve design and supply the best possible product.

Philips Semiconductors and Philips Electronics North America Corporation reserve the right to make changes, without notice, in the products, including circuits, standard cells, and/or software, described or contained herein in order to improve design and/or performance. Philips Semiconductors assumes no responsibility or liability for the use of any of these products, conveys no license or title under any patent, copyright, or mask work right to these products, and makes no representations or warranties that these products are free from patent, copyright, or mask work right infringement, unless otherwise specified. Applications that are described herein for any of these products are for illustrative purposes only. Philips Semiconductors makes no representation or warranty that such applications will be suitable for the specified use without further testing or modification.

LIFE SUPPORT APPLICATIONS

Philips Semiconductors and Philips Electronics North America Corporation Products are not designed for use in life support appliances, devices, or systems where malfunction of a Philips Semiconductors and Philips Electronics North America Corporation Product can reasonably be expected to result in a personal injury. Philips Semiconductors and Philips Electronics North America Corporation customers using or selling Philips Semiconductors and Philips Electronics North America Corporation Products for use in such applications do so at their own risk and agree to fully indemnify Philips Semiconductors and Philips Electronics North America Corporation for any damages resulting from such improper use or sale.

Philips Semiconductors
 811 East Arques Avenue
 P.O. Box 3409
 Sunnyvale, California 94088-3409
 Telephone 800-234-7381

© Copyright Philips Electronics North America Corporation 1997
 All rights reserved. Printed in U.S.A.

Let's make things better.

**Philips
 Semiconductors**



PHILIPS