



FAST CMOS 12-BIT SYNCHRONOUS BUS EXCHANGER

IDT74FCT162H272AT/CT

FEATURES:

- 0.5 MICRON CMOS Technology
- Typical $t_{sk(o)}$ (Output Skew) < 250ps
- Low input and output leakage $\leq 1\mu A$ (max.)
- ESD > 2000V per MIL-STD-883, Method 3015; > 200V using machine model (C = 200pF, R = 0)
- Balanced Output Drivers: $\pm 24mA$
- Reduced system switching noise
- Typical VOLP (Output Ground Bounce) < 0.6V at $V_{cc} = 5V$, $T_A = 25^\circ C$
- Bus Hold retains last active bus state during 3-state
- Eliminates the need for external pull up resistors
- Available in SSOP and TSSOP packages

DESCRIPTION:

The FCT162H272T synchronous tri-port bus exchangers are high-speed, bidirectional, 12-bit, registered, bus multiplexers for use in synchronous memory interleaving applications. All registers have a common clock and use a clock enable (\overline{CE}_{xxx}) on each data register to control data sequencing. The output enables and mux select (\overline{OEA} , \overline{OEB} and SEL) are also under synchronous control allowing direction changes to be edge triggered events.

The tri-port bus exchanger has three 12-bit ports. Data may be transferred between the A port and either/both of the B ports. The clock enable (\overline{CE}_{1B} , \overline{CE}_{2B} , \overline{CE}_{A1B} and \overline{CE}_{A2B}) inputs control the data storage. Both B ports have a common output enable (\overline{OEB}) to aid in synchronously loading the B registers from the B port.

The FCT162H272T has balanced output drive with current limiting resistors. This offers low ground bounce, minimal undershoot, and controlled output fall times-reducing the need for external series terminating resistors.

The FCT162H272T has "Bus Hold" which retains the input's last state whenever the input goes to high impedance. This prevents "floating" inputs and eliminates the need for pull-up/down resistors.

FUNCTIONAL BLOCK DIAGRAM

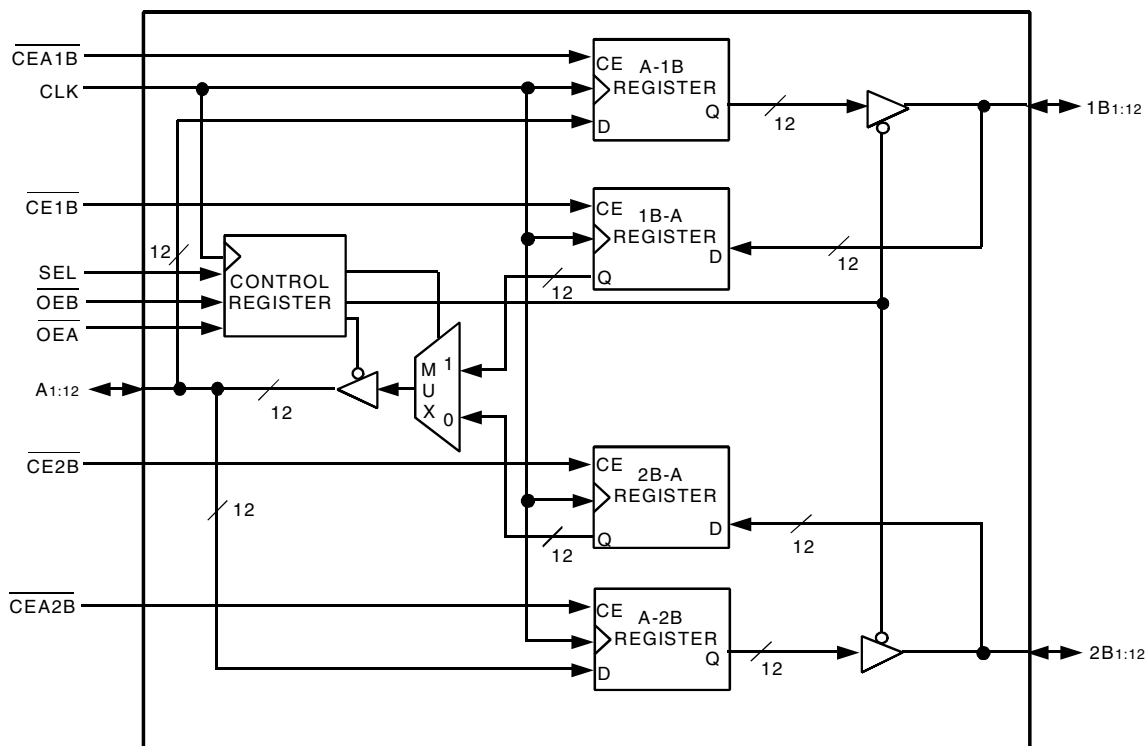

The IDT logo is a registered trademark of Integrated Device Technology, Inc.

INDUSTRIAL TEMPERATURE RANGE

NOVEMBER 2002

PIN CONFIGURATION

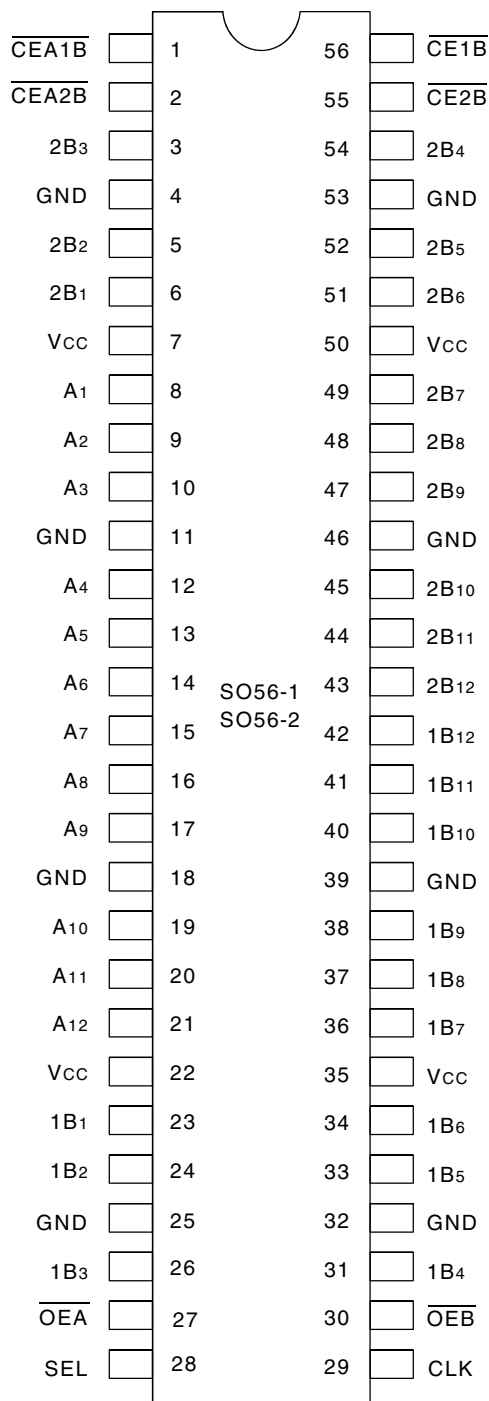

SSOP/ TSSOP
TOP VIEW

ABSOLUTE MAXIMUM RATINGS⁽¹⁾

Symbol	Description	Max	Unit
VTERM ⁽²⁾	Terminal Voltage with Respect to GND	-0.5 to 7	V
VTERM ⁽³⁾	Terminal Voltage with Respect to GND	-0.5 to VCC+0.5	V
TSTG	Storage Temperature	-65 to +150	°C
IOUT	DC Output Current	-60 to +120	mA

NOTES:

1. Stresses greater than those listed under ABSOLUTE MAXIMUM RATINGS may cause permanent damage to the device. This is a stress rating only and functional operation of the device at these or any other conditions above those indicated in the operational sections of this specification is not implied. Exposure to absolute maximum rating conditions for extended periods may affect reliability.
2. All device terminals except FCT162XXX Output and I/O terminals.
3. Output and I/O terminals for FCT162XXXT.

CAPACITANCE (TA = +25°C, f = 1.0MHz)

Symbol	Parameter ⁽¹⁾	Conditions	Typ.	Max.	Unit
CIN	Input Capacitance	VIN = 0V	3.5	6	pF
COUT	Output Capacitance	VOUT = 0V	3.5	8	pF

NOTE:

1. This parameter is measured at characterization but not tested.

PIN DESCRIPTION

Signal	I/O	Description
A(1:12)	I/O	Bidirectional Data Port A. Usually connected to the CPU's Address/Data bus. ⁽¹⁾
1B(1:12)	I/O	Bidirectional Data Port 1B. Usually connected to the even path or even bank of memory. ⁽¹⁾
2B(1:12)	I/O	Bidirectional Data Port 2B. Usually connected to the odd path or odd bank of memory. ⁽¹⁾
CLK	I	Clock Input
$\overline{\text{CEA1B}}$	I	Clock Enable Input for the A-1B Register. If CEA1B is LOW during the rising edge of CLK, data will be clocked into register A-1B (Active LOW).
$\overline{\text{CEA2B}}$	I	Clock Enable Input for the A-2B Register. If CEA2B is LOW during the rising edge of CLK, data will be clocked into register A-2B (Active LOW).
$\overline{\text{CE1B}}$	I	Clock Enable Input for the 1B-A Register. If CE1B is LOW during the rising edge of CLK, data will be clocked into register 1B-A (Active LOW).
$\overline{\text{CE2B}}$	I	Clock Enable Input for the 2B-A Register. If CE2B is LOW during the rising edge of CLK, data will be clocked into register 2B-A (Active LOW).
SEL	I	1B or 2B Path Selection. When HIGH during the rising edge of CLK, SEL enables data transfer from 1B Port to A Port. When LOW during the rising edge of CLK, SEL enables data transfer from 2B Port to A Port.
$\overline{\text{OE}}\overline{\text{A}}$	I	Synchronous Output Enable for A Port (Active LOW).
$\overline{\text{OE}}\overline{\text{B}}$	I	Synchronous Output Enable for 1B Port and 2B Port (Active LOW).

NOTE:

1. On FCT162H272T these pins have "Bus Hold". All other pins are standard inputs, outputs or I/Os.

FUNCTION TABLES⁽²⁾

Inputs							Output
1B	2B	SEL	$\overline{\text{CE1B}}$	$\overline{\text{CE2B}}$	$\overline{\text{OE}}\overline{\text{A}}$	CLK	A
H	X	H	L	X	L	↑	H
L	X	H	L	X	L	↑	L
X	X	H	H	X	L	↑	A ⁽¹⁾
X	H	L	X	L	L	↑	H
X	L	L	X	L	L	↑	L
X	X	L	X	H	L	↑	A ⁽¹⁾
X	X	X	X	X	H	↑	Z

Inputs					Outputs	
A	$\overline{\text{CEA1B}}$	$\overline{\text{CEA2B}}$	$\overline{\text{OE}}\overline{\text{B}}$	CLK	1B	2B
H	L	L	L	↑	H	H
L	L	L	L	↑	L	L
H	L	H	L	↑	H	B ⁽¹⁾
L	L	H	L	↑	L	B ⁽¹⁾
H	H	L	L	↑	B ⁽¹⁾	H
L	H	L	L	↑	B ⁽¹⁾	L
X	H	H	L	↑	B ⁽¹⁾	B ⁽¹⁾
X	X	X	H	↑	Z	Z
X	X	X	L	↑	Active	Active

NOTES:

1. Output level before the indicated steady-state input conditions were established.

2. H = HIGH Voltage Level

L = LOW Voltage Level

X = Don't Care

Z = High-Impedance

↑ = LOW-to-HIGH Transition

DC ELECTRICAL CHARACTERISTICS OVER OPERATING RANGE (BUS HOLD)

Following Conditions Apply Unless Otherwise Specified:

Industrial: $T_A = -40^{\circ}\text{C}$ to $+85^{\circ}\text{C}$, $V_{CC} = 5.0\text{V} \pm 10\%$

Symbol	Parameter		Test Conditions ⁽¹⁾		Min.	Typ. ⁽²⁾	Max.	Unit
V_{IH}	Input HIGH Level		Guaranteed Logic HIGH Level		2	—	—	V
V_{IL}	Input LOW Level		Guaranteed Logic LOW Level		—	—	0.8	V
I_{IH}	Input HIGH Current ⁽⁴⁾	Standard Input ⁽⁵⁾	$V_{CC} = \text{Max.}$	$V_I = V_{CC}$	—	—	± 1	μA
		Standard I/O ⁽⁵⁾			—	—	± 1	
		Bus-hold Input			—	—	± 100	
		Bus-hold I/O			—	—	± 100	
I_{IL}	Input LOW Current ⁽⁴⁾	Standard Input ⁽⁵⁾	$V_{CC} = \text{Max.}$	$V_I = \text{GND}$	—	—	± 1	μA
		Standard I/O ⁽⁵⁾			—	—	± 1	
		Bus-hold Input			—	—	± 100	
		Bus-hold I/O			—	—	± 100	
I_{BHH} I_{BHL}	Bus-hold Sustain Current ⁽⁴⁾	Bus-hold Input	$V_{CC} = \text{Min.}$	$V_I = 2\text{V}$ $V_I = 0.8\text{V}$	-50 50	— —	— —	μA
I_{OZH} I_{OZL}	High Impedance Output Current (3-State Output pins) ^(5,6)		$V_{CC} = \text{Max.}$	$V_O = 2.7\text{V}$ $V_O = 0.5\text{V}$	— —	— —	± 1 ± 1	μA
V_{IK}	Clamp Diode Voltage		$V_{CC} = \text{Min.}, I_{IN} = -18\text{mA}$		—	-0.7	-1.2	V
I_{OS}	Short Circuit Current		$V_{CC} = \text{Max.}, V_O = \text{GND}^{(3)}$		-80	-140	-250	mA
V_H	Input Hysteresis		—		—	100	—	mV
I_{CCL} I_{CCH} I_{CCZ}	Quiescent Power Supply Current		$V_{CC} = \text{Max.}$ $V_{IN} = \text{GND or } V_{CC}$		—	5	500	μA

OUTPUT DRIVE CHARACTERISTICS

Symbol	Parameter	Test Conditions ⁽¹⁾		Min.	Typ. ⁽²⁾	Max.	Unit
I_{ODL}	Output LOW Current	$V_{CC} = 5\text{V}, V_{IN} = V_{IH} \text{ or } V_{IL}, V_O = 1.5\text{V}^{(3)}$		60	115	200	mA
I_{ODH}	Output HIGH Current	$V_{CC} = 5\text{V}, V_{IN} = V_{IH} \text{ or } V_{IL}, V_O = 1.5\text{V}^{(3)}$		-60	-115	-200	mA
V_{OH}	Output HIGH Voltage	$V_{CC} = \text{Min.}$ $V_{IN} = V_{IH} \text{ or } V_{IL}$	$I_{OH} = -24\text{mA}$	2.4	3.3	—	V
V_{OL}	Output LOW Voltage	$V_{CC} = \text{Min.}$ $V_{IN} = V_{IH} \text{ or } V_{IL}$	$I_{OH} = 24\text{mA}$	—	0.3	0.55	V

NOTES:

- For conditions shown as Min. or Max., use appropriate value specified under Electrical Characteristics for the applicable device type.
- Typical values are at $V_{CC} = 5.0\text{V}$, $+25^{\circ}\text{C}$ ambient.
- Not more than one output should be shorted at one time. Duration of the test should not exceed one second.
- Duration of the condition can not exceed one second.
- This test limit for this parameter is $\pm 5\mu\text{A}$ at $T_A = -55^{\circ}\text{C}$.
- Does not include Bus-Hold I/O pins.

POWER SUPPLY CHARACTERISTICS

Symbol	Parameter	Test Conditions ⁽¹⁾		Min.	Typ. ⁽²⁾	Max.	Unit
ΔI_{CC}	Quiescent Power Supply Current TTL Inputs HIGH	V _{CC} = Max. V _{IN} = 3.4V ⁽³⁾		—	0.5	1.5	mA
I _{CCD}	Dynamic Power Supply Current ⁽⁴⁾	V _{CC} = Max. Outputs Open One Output Port Enabled \overline{CE}_{EX} = GND One Input Bit Toggling One Output Bit Toggling 50% Duty Cycle	V _{IN} = V _{CC} V _{IN} = GND	—	60	100	μA/ MHz
I _C	Total Power Supply Current ⁽⁶⁾	V _{CC} = Max. Outputs Open f _{CP} = 10MHz 50% Duty Cycle \overline{OE}_{EX} = \overline{CE}_{EX} = GND One Input Bit Toggling One Output Bit Toggling f _i = 5MHz 50% Duty Cycle	V _{IN} = V _{CC} V _{IN} = GND	—	0.6	1	mA
			V _{IN} = 3.4V V _{IN} = GND	—	1.1	2.5	
		V _{CC} = Max. Outputs Open f _{CP} = 10MHz 50% Duty Cycle \overline{OE}_{EX} = \overline{CE}_{EX} = GND Twelve Input Bits Toggling Twelve Output Bits Toggling f _i = 2.5MHz 50% Duty Cycle	V _{IN} = V _{CC} V _{IN} = GND	—	2.1	3.5 ⁽⁵⁾	
			V _{IN} = 3.4V V _{IN} = GND	—	5.4	13.3 ⁽⁵⁾	

NOTES:

- For conditions shown as Min. or Max., use appropriate value specified under Electrical Characteristics for the applicable device type.
- Typical values are at V_{CC} = 5.0V, +25°C ambient.
- Per TTL driven input (V_{IN} = 3.4V). All other inputs at V_{CC} or GND.
- This parameter is not directly testable, but is derived for use in Total Power Supply Calculations.
- Values for these conditions are examples of the I_{CC} formula. These limits are guaranteed but not tested.
- I_C = I_{QUIESCENT} + I_{INPUTS} + I_{DYNAMIC}
 $I_C = I_{CC} + \Delta I_{CC} D_H N_T + I_{CCD} (f_{CP} N_{CP} / 2 + f_i N_i)$
 I_{CC} = Quiescent Current (I_{CC1}, I_{CC2} and I_{CC3})
 ΔI_{CC} = Power Supply Current for a TTL High Input (V_{IN} = 3.4V)
 D_H = Duty Cycle for TTL Inputs High
 N_T = Number of TTL Inputs at D_H
 I_{CCD} = Dynamic Current caused by an Input Transition Pair (HLH or LHL)
 f_{CP} = Clock Frequency for Register Devices (Zero for Non-Register Devices)
 N_{CP} = Number of Clock Inputs at f_{CP}
 f_i = Input Frequency
 N_i = Number of Inputs at f_i

SWITCHING CHARACTERISTICS OVER OPERATING RANGE

Symbol	Parameter		Condition ⁽¹⁾	FCT162H272AT		FCT162H272CT		Unit
				Min. ⁽²⁾	Max.	Min. ⁽²⁾	Max.	
t _{PLH} t _{PHL}	Propagation Delay CLK to 1Bx or CLK to 2Bx		C _L = 50pF R _L = 500Ω	1.5	5.8	1.5	5.2	ns
t _{PLH} t _{PHL}	Propagation Delay CLK to Ax	SEL Stable $\overline{\text{CE}}\text{xB}$ Enabled		1.5	6	1.5	5.4	ns
		SEL Changing $\overline{\text{CE}}\text{xB}$ Disabled		1.5	6	1.5	5.4	ns
		SEL Changing $\overline{\text{CE}}\text{xB}$ Enabled		1.5	7.6	1.5	6.6	ns
t _{PZH} t _{PZL}	Output Enable Time CLK to Ax, CLK to 1Bx, or CLK to 2Bx			1.5	7.7	1.5	6.8	ns
t _{PHZ} t _{PLZ}	Output Disable Time CLK to Ax, CLK to 1Bx, or CLK to 2Bx			1.5	6.4	1.5	6	ns
t _{SU}	Set-Up Time, HIGH or LOW Data to CLK			2	—	2	—	ns
t _{SU}	Set-Up Time, $\overline{\text{OE}}\text{A}$ to CLK, $\overline{\text{OE}}\text{B}$ to CLK			2	—	2	—	ns
t _{SU}	Set-Up Time, SEL to CLK			2	—	2	—	ns
t _{SU}	Set-Up Time, $\overline{\text{CE}}\text{A1B}$ to CLK, $\overline{\text{CE}}\text{1B}$ to CLK, $\overline{\text{CE}}\text{2B}$ to CLK, or $\overline{\text{CE}}\text{A2B}$ to CLK			2	—	2	—	ns
t _H	Hold Time, CLK to Data			0	—	0	—	ns
t _H	Hold Time, CLK to $\overline{\text{OE}}\text{A}$, CLK to $\overline{\text{OE}}\text{B}$, CLK to SEL			0.5	—	0.5	—	ns
t _H	Hold Time, CLK to $\overline{\text{CE}}\text{A1B}$, CLK to $\overline{\text{CE}}\text{1B}$, CLK to $\overline{\text{CE}}\text{2B}$, CLK to $\overline{\text{CE}}\text{A2B}$			0	—	0	—	ns
t _w	Pulse Width, CLK HIGH ⁽³⁾			3	—	3	—	ns
t _{SK(o)}	Output Skew ⁽⁴⁾		—	0.5	—	0.5	ns	

NOTES:

1. See test circuits and waveforms.
2. Minimum limits are guaranteed but not tested on Propagation Delays.
3. This parameter is guaranteed but not tested.
4. Skew between any two outputs of the same package switching in the same direction. This parameter is guaranteed by design.

TEST CIRCUITS AND WAVEFORMS

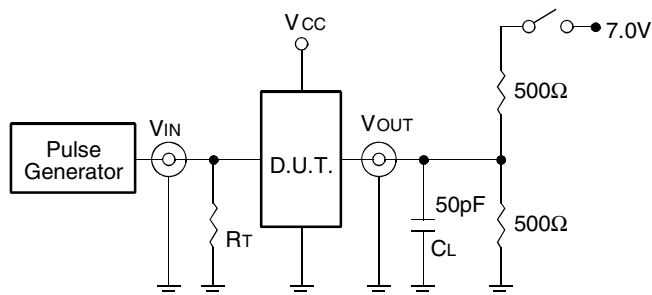

Test Circuits for All Outputs

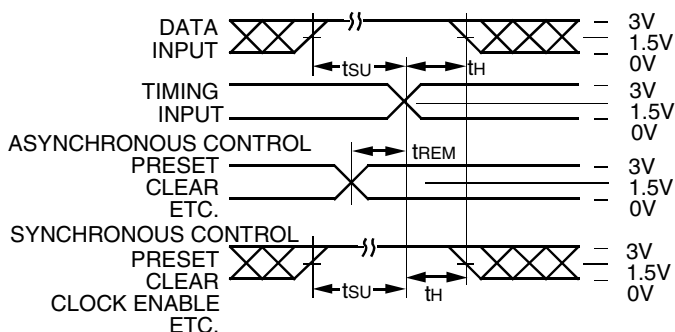

Set-up, Hold, and Release Times

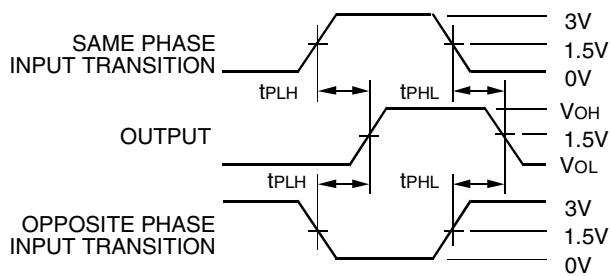

Propagation Delay

SWITCH POSITION

Test	Switch
Open Drain Disable Low Enable Low	Closed
All Other Tests	Open

DEFINITIONS:

CL = Load capacitance: includes jig and probe capacitance.
RT = Termination resistance: should be equal to Zout of the Pulse Generator.

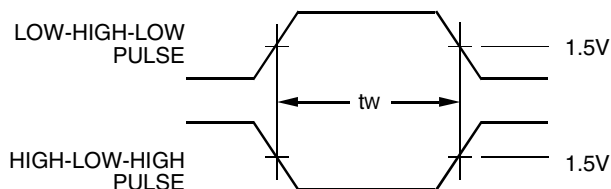

Pulse Width

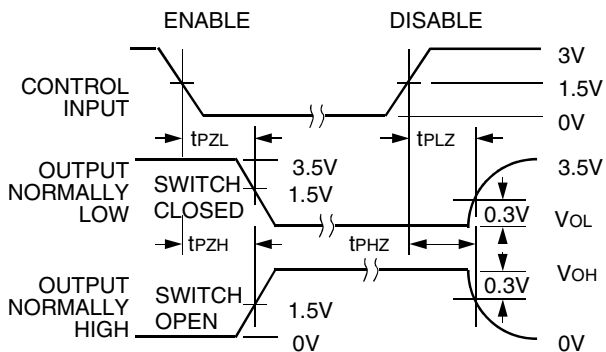

Enable and Disable Times

NOTES:

1. Diagram shown for input Control Enable-LOW and input Control Disable-HIGH.
2. Pulse Generator for All Pulses: Rate ≤ 1.0MHz; tr ≤ 2.5ns; tr ≤ 2.5ns.

ORDERING INFORMATION

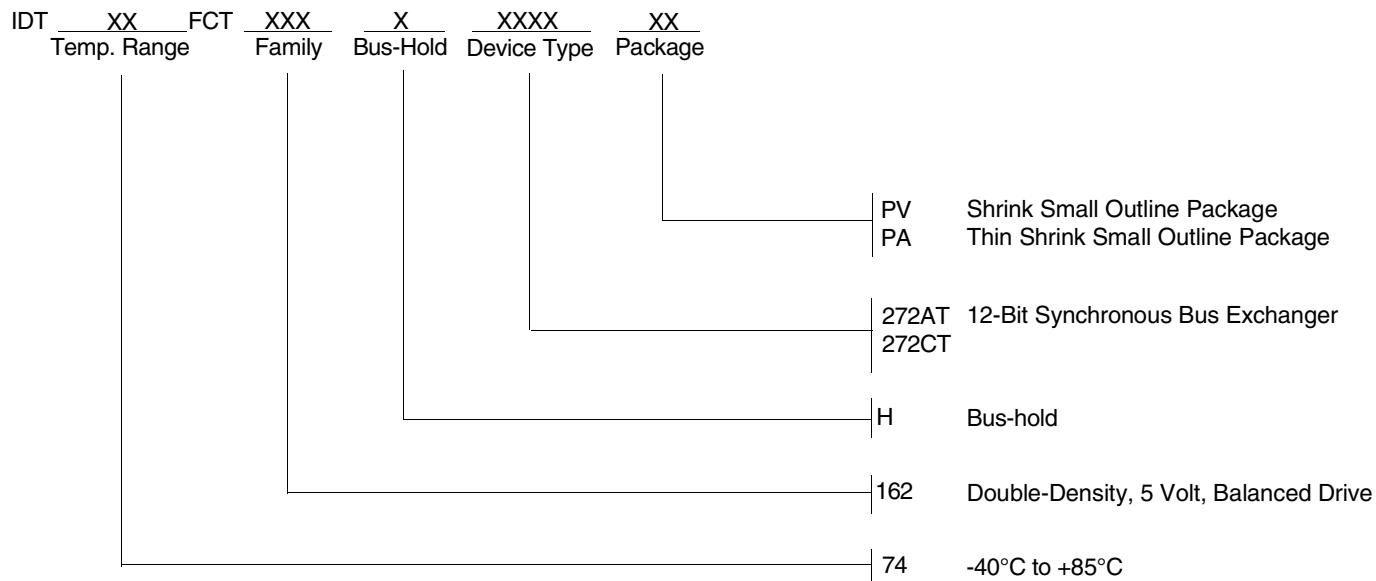

CORPORATE HEADQUARTERS
 6024 Silver Creek Valley Road
 San Jose, CA 95138

for SALES:
 800-345-7015 or 408-284-8200
 fax: 408-284-2775
 www.idt.com

for Tech Support:
 logichelp@idt.com