

DATA SHEET

74AHC3G04; 74AHCT3G04

Inverter

Product specification

2003 Nov 06

Inverter

74AHC3G04; 74AHCT3G04

FEATURES

- Symmetrical output impedance
- High noise immunity
- ESD protection:
 - HBM EIA/JESD22-A114-A exceeds 2000 V
 - MM EIA/JESD22-A115-A exceeds 200 V
 - CDM EIA/JESD22-C101 exceeds 1000 V.
- Low power dissipation
- Balanced propagation delays
- SOT505-2 and SOT765-1 package
- Specified from -40 to +85 °C and -40 to +125 °C.

DESCRIPTION

The 74AHC3G04/74AHCT3G04 are high-speed Si-gate CMOS devices.

The 74AHC3G04/74AHCT3G04 provides three inverting buffer.

QUICK REFERENCE DATA

GND = 0 V; T_{amb} = 25 °C; t_r = t_f ≤ 3.0 ns.

SYMBOL	PARAMETER	CONDITIONS	TYPICAL		UNIT
			74AHC3G04	74AHCT3G04	
t _{PHL} /t _{PLH}	propagation delay input A to output Y	C _L = 15 pF; V _{CC} = 5 V	3.1	3.4	ns
C _I	input capacitance		1.5	1.5	pF
C _{PD}	power dissipation capacitance	C _L = 50 pF; f = 1 MHz; notes 1 and 2	9	10	pF

Notes

1. C_{PD} is used to determine the dynamic power dissipation (P_D in μW).

$$P_D = C_{PD} \times V_{CC}^2 \times f_i \times N + \sum(C_L \times V_{CC}^2 \times f_o) \text{ where:}$$

f_i = input frequency in MHz;

f_o = output frequency in MHz;

C_L = output load capacitance in pF;

V_{CC} = supply voltage in Volts;

N = total load switching outputs;

∑(C_L × V_{CC}² × f_o) = sum of outputs.

2. The condition is V_I = GND to V_{CC}.

FUNCTION TABLE

See note 1.

INPUT	OUTPUT
nA	nY
L	H
H	L

Note

1. H = HIGH voltage level;
L = LOW voltage level.

Inverter

74AHC3G04; 74AHCT3G04

ORDERING AND PACKAGE INFORMATION

TYPE NUMBER	PACKAGES					
	TEMPERATURE RANGE	PINS	PACKAGE	MATERIAL	CODE	MARKING
74AHC3G04DP	-40 to +125 °C	8	TSSOP8	plastic	SOT505-2	A04
74AHCT3G04DP	-40 to +125 °C	8	TSSOP8	plastic	SOT505-2	C04
74AHC3G04DC	-40 to +125 °C	8	VSSOP8	plastic	SOT765-1	A04
74AHCT3G04DC	-40 to +125 °C	8	VSSOP8	plastic	SOT765-1	C04

PINNING

PIN	SYMBOL	DESCRIPTION
1	1A	data input
2	3Y	data output
3	2A	data input
4	GND	ground (0 V)
5	2Y	data output
6	3A	data input
7	1Y	data output
8	V _{CC}	supply voltage

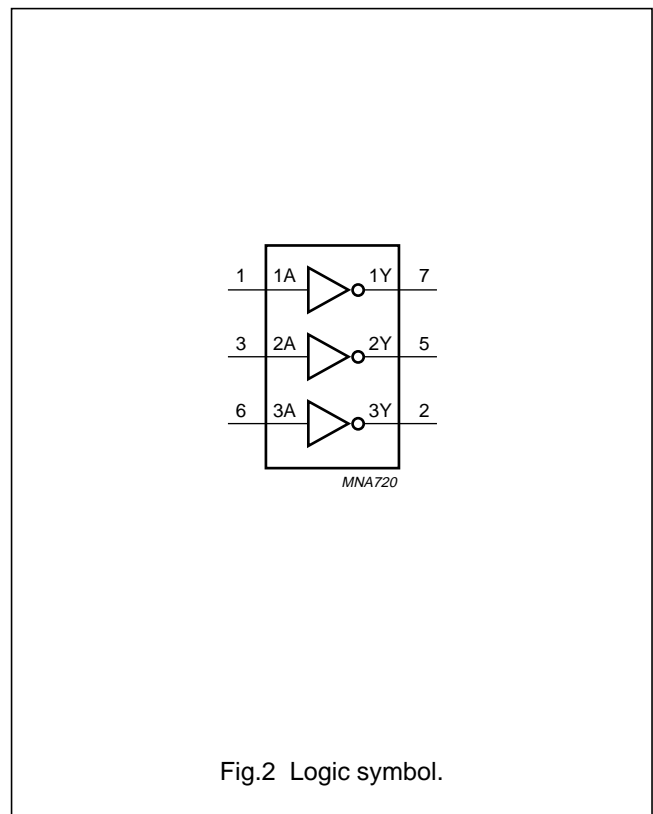
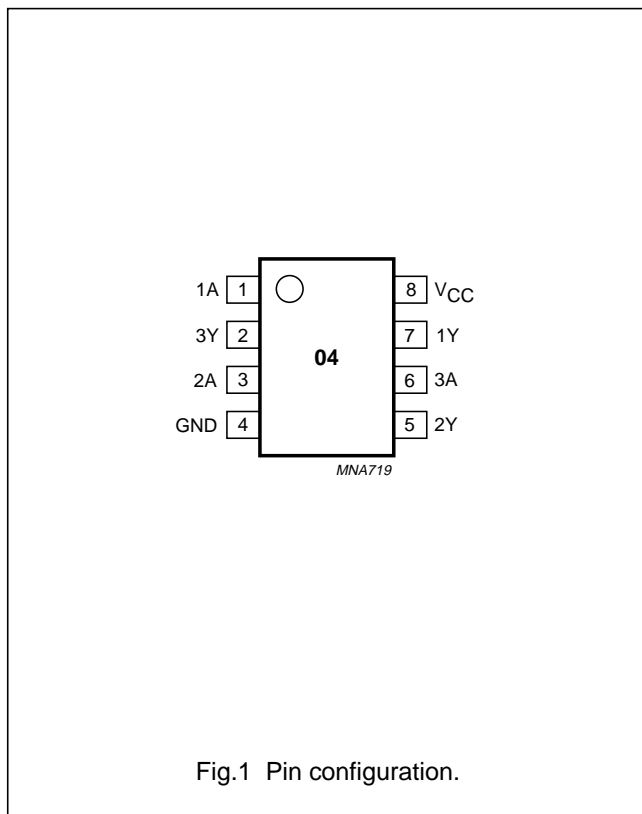

Inverter

74AHC3G04; 74AHCT3G04

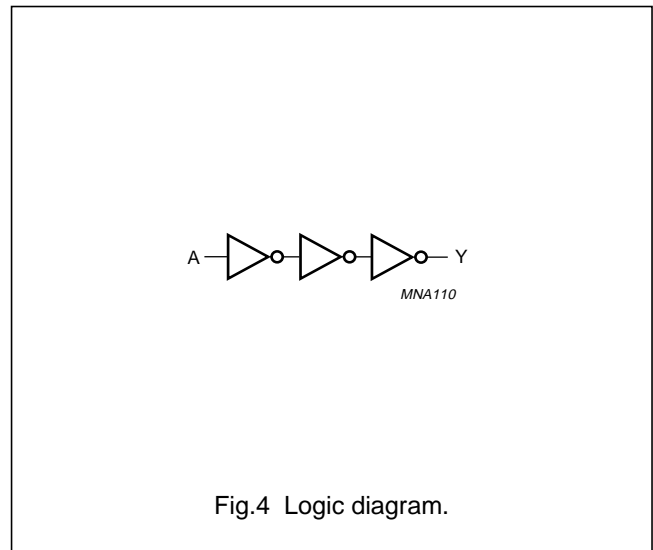
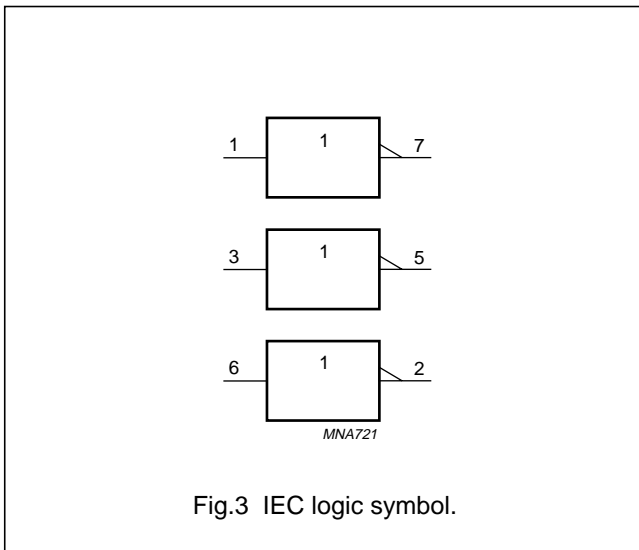

RECOMMENDED OPERATING CONDITIONS

SYMBOL	PARAMETER	CONDITIONS	74AHC3G04			74AHCT3G04			UNIT
			MIN.	TYP.	MAX.	MIN.	TYP.	MAX.	
V_{CC}	supply voltage		2.0	5.0	5.5	4.5	5.0	5.5	V
V_I	input voltage		0	–	5.5	0	–	5.5	V
V_O	output voltage		0	–	V_{CC}	0	–	V_{CC}	V
T_{amb}	operating ambient temperature	see DC and AC characteristics per device	–40	+25	+125	–40	+25	+125	°C
$t_r, t_f (\Delta t/\Delta f)$	input rise and fall times	$V_{CC} = 3.3 \pm 0.3 V$	–	–	100	–	–	–	ns/V
		$V_{CC} = 5 \pm 0.5 V$	–	–	20	–	–	20	ns/V

LIMITING VALUES

In accordance with the Absolute Maximum Rating System (IEC 60134); voltages are referenced to GND (ground = 0 V).

SYMBOL	PARAMETER	CONDITIONS	MIN.	MAX.	UNIT
V_{CC}	supply voltage		–0.5	+7.0	V
V_I	input voltage		–0.5	+7.0	V
I_{IK}	input diode current	$V_I < -0.5 V$	–	–20	mA
I_{OK}	output diode current	$-0.5 V < V_O < V_{CC} + 0.5 V$; note 1	–	± 20	mA
I_O	output source or sink current	$-0.5 V < V_O < V_{CC} + 0.5 V$	–	± 25	mA
I_{CC}, I_{GND}	V_{CC} or GND current		–	± 75	mA
T_{stg}	storage temperature		–65	+150	°C
P_D	power dissipation	$T_{amb} = -40 \text{ to } +125 \text{ }^\circ\text{C}$	–	250	mW

Note

1. The input and output voltage ratings may be exceeded if the input and output current ratings are observed.

Inverter

74AHC3G04; 74AHCT3G04

DC CHARACTERISTICS

Type 74AHC3G04

At recommended operating conditions; voltages are referenced to GND (ground = 0 V).

SYMBOL	PARAMETER	TEST CONDITIONS		MIN.	TYP.	MAX.	UNIT
		OTHER	V _{CC} (V)				
T_{amb} = 25 °C							
V _{IH}	HIGH-level input voltage		2.0	1.5	–	–	V
			3.0	2.1	–	–	V
			5.5	3.85	–	–	V
V _{IL}	LOW-level input voltage		2.0	–	–	0.5	V
			3.0	–	–	0.9	V
			5.5	–	–	1.65	V
V _{OH}	HIGH-level output voltage	V _I = V _{IH} or V _{IL} I _O = –50 µA	2.0	1.9	2.0	–	V
		I _O = –50 µA	3.0	2.9	3.0	–	V
		I _O = –50 µA	4.5	4.4	4.5	–	V
		I _O = –4.0 mA	3.0	2.58	–	–	V
		I _O = –8.0 mA	4.5	3.94	–	–	V
V _{OL}	LOW-level output voltage	V _I = V _{IH} or V _{IL} I _O = 50 µA	2.0	–	0	0.1	V
		I _O = 50 µA	3.0	–	0	0.1	V
		I _O = 50 µA	4.5	–	0	0.1	V
		I _O = 4.0 mA	3.0	–	–	0.36	V
		I _O = 8.0 mA	4.5	–	–	0.36	V
I _{LI}	input leakage current	V _I = V _{CC} or GND	5.5	–	–	0.1	µA
I _{CC}	quiescent supply current	V _I = V _{CC} or GND; I _O = 0	5.5	–	–	10	µA
C _I	input capacitance		–	–	1.5	10	pF

Inverter

74AHC3G04; 74AHCT3G04

SYMBOL	PARAMETER	TEST CONDITIONS		MIN.	TYP.	MAX.	UNIT
		OTHER	V _{CC} (V)				
T_{amb} = -40 to +85 °C							
V _{IH}	HIGH-level input voltage		2.0	1.5	–	–	V
			3.0	2.1	–	–	V
			5.5	3.85	–	–	V
V _{IL}	LOW-level input voltage		2.0	–	–	0.5	V
			3.0	–	–	0.9	V
			5.5	–	–	1.65	V
V _{OH}	HIGH-level output voltage	V _I = V _{IH} or V _{IL} I _O = -50 µA	2.0	1.9	–	–	V
		I _O = -50 µA	3.0	2.9	–	–	V
		I _O = -50 µA	4.5	4.4	–	–	V
		I _O = -4.0 mA	3.0	2.48	–	–	V
		I _O = -8.0 mA	4.5	3.8	–	–	V
V _{OL}	LOW-level output voltage	V _I = V _{IH} or V _{IL} I _O = 50 µA	2.0	–	–	0.1	V
		I _O = 50 µA	3.0	–	–	0.1	V
		I _O = 50 µA	4.5	–	–	0.1	V
		I _O = 4.0 mA	3.0	–	–	0.44	V
		I _O = 8.0 mA	4.5	–	–	0.44	V
I _{LI}	input leakage current	V _I = V _{CC} or GND	5.5	–	–	1.0	µA
I _{CC}	quiescent supply current	V _I = V _{CC} or GND; I _O = 0	5.5	–	–	10	µA
C _I	input capacitance		–	–	–	10	pF

Inverter

74AHC3G04; 74AHCT3G04

SYMBOL	PARAMETER	TEST CONDITIONS		MIN.	TYP.	MAX.	UNIT
		OTHER	V _{CC} (V)				
T_{amb} = -40 to +125 °C							
V _{IH}	HIGH-level input voltage		2.0	1.5	–	–	V
			3.0	2.1	–	–	V
			5.5	3.85	–	–	V
V _{IL}	LOW-level input voltage		2.0	–	–	0.5	V
			3.0	–	–	0.9	V
			5.5	–	–	1.65	V
V _{OH}	HIGH-level output voltage	V _I = V _{IH} or V _{IL} I _O = -50 µA	2.0	1.9	–	–	V
		I _O = -50 µA	3.0	2.9	–	–	V
		I _O = -50 µA	4.5	4.4	–	–	V
		I _O = -4.0 mA	3.0	2.40	–	–	V
		I _O = -8.0 mA	4.5	3.70	–	–	V
V _{OL}	LOW-level output voltage	V _I = V _{IH} or V _{IL} I _O = 50 µA	2.0	–	–	0.1	V
		I _O = 50 µA	3.0	–	–	0.1	V
		I _O = 50 µA	4.5	–	–	0.1	V
		I _O = 4.0 mA	3.0	–	–	0.55	V
		I _O = 8.0 mA	4.5	–	–	0.55	V
I _{LI}	input leakage current	V _I = V _{CC} or GND	5.5	–	–	2.0	µA
I _{CC}	quiescent supply current	V _I = V _{CC} or GND; I _O = 0	5.5	–	–	40	µA
C _I	input capacitance		–	–	–	10	pF

Inverter

74AHC3G04; 74AHCT3G04

Type 74AHCT3G04

At recommended operating conditions; voltages are referenced to GND (ground = 0 V).

SYMBOL	PARAMETER	TEST CONDITIONS		MIN.	TYP.	MAX.	UNIT
		OTHER	V _{CC} (V)				
T_{amb} = 25 °C							
V _{IH}	HIGH-level input voltage		4.5 to 5.5	2.0	–	–	V
V _{IL}	LOW-level input voltage		4.5 to 5.5	–	–	0.8	V
V _{OH}	HIGH-level output voltage	V _I = V _{IH} or V _{IL} I _O = –50 µA	4.5	4.4	4.5	–	V
		I _O = –8.0 mA	4.5	3.94	–	–	V
V _{OL}	LOW-level output voltage	V _I = V _{IH} or V _{IL} I _O = 50 µA	4.5	–	0	0.1	V
		I _O = 8.0 mA	4.5	–	–	0.36	V
I _{LI}	input leakage current	V _I = V _{IH} or V _{IL}	5.5	–	–	0.1	µA
I _{CC}	quiescent supply current	V _I = V _{CC} or GND; I _O = 0	5.5	–	–	1.0	µA
ΔI _{CC}	additional quiescent supply current per input pin	V _I = 3.4 V; other inputs at V _{CC} or GND; I _O = 0	5.5	–	–	1.35	mA
C _I	input capacitance			–	1.5	10	pF
T_{amb} = –40 to +85 °C							
V _{IH}	HIGH-level input voltage		4.5 to 5.5	2.0	–	–	V
V _{IL}	LOW-level input voltage		4.5 to 5.5	–	–	0.8	V
V _{OH}	HIGH-level output voltage	V _I = V _{IH} or V _{IL} I _O = –50 µA	4.5	4.4	–	–	V
		I _O = –8.0 mA	4.5	3.8	–	–	V
V _{OL}	LOW-level output voltage	V _I = V _{IH} or V _{IL} I _O = 50 µA	4.5	–	–	0.1	V
		I _O = 8.0 mA	4.5	–	–	0.44	V
I _{LI}	input leakage current	V _I = V _{IH} or V _{IL}	5.5	–	–	1.0	µA
I _{CC}	quiescent supply current	V _I = V _{CC} or GND; I _O = 0	5.5	–	–	10	µA
ΔI _{CC}	additional quiescent supply current per input pin	V _I = 3.4 V; other inputs at V _{CC} or GND; I _O = 0	5.5	–	–	1.5	mA
C _I	input capacitance		–	–	–	10	pF

Inverter

74AHC3G04; 74AHCT3G04

SYMBOL	PARAMETER	TEST CONDITIONS		MIN.	TYP.	MAX.	UNIT
		OTHER	V _{CC} (V)				
T_{amb} = -40 to +125 °C							
V _{IH}	HIGH-level input voltage		4.5 to 5.5	2.0	–	–	V
V _{IL}	LOW-level input voltage		4.5 to 5.5	–	–	0.8	V
V _{OH}	HIGH-level output voltage	V _I = V _{IH} or V _{IL}	4.5	4.4	–	–	V
		I _O = -50 μA I _O = -8.0 mA	4.5	3.70	–	–	V
V _{OL}	LOW-level output voltage	V _I = V _{IH} or V _{IL}	4.5	–	–	0.1	V
		I _O = 50 μA I _O = 8.0 mA	4.5	–	–	0.55	V
I _{LI}	input leakage current	V _I = V _{IH} or V _{IL}	5.5	–	–	2.0	μA
I _{CC}	quiescent supply current	V _I = V _{CC} or GND; I _O = 0	5.5	–	–	40	μA
ΔI _{CC}	additional quiescent supply current per input pin	V _I = 3.4 V; other inputs at V _{CC} or GND; I _O = 0	5.5	–	–	1.5	mA
C _I	input capacitance		–	–	–	10	pF

Inverter

74AHC3G04; 74AHCT3G04

AC CHARACTERISTICS

Type 74AHC3G04

GND = 0 V; $t_r = t_f \leq 3.0$ ns.

SYMBOL	PARAMETER	TEST CONDITIONS			MIN.	TYP.	MAX.	UNIT
		WAVEFORMS	C_L (pF)	V_{CC} (V)				
$T_{amb} = 25\text{ }^\circ\text{C}$								
t_{PHL}/t_{PLH}	propagation delay input nA to output nY	see Figs 5 and 6	15	3.0 to 3.6	–	–	7.1	ns
				3.3	–	4.3	–	ns
				4.5 to 5.5	–	–	5.5	ns
				5	–	3.1	–	ns
		50	3.0 to 3.6	–	–	10.6	ns	
			3.3	–	6.1	–	ns	
			4.5 to 5.5	–	–	7.5	ns	
			5	–	4.5	–	ns	
$T_{amb} = -40\text{ to }+85\text{ }^\circ\text{C}$								
t_{PHL}/t_{PLH}	propagation delay input nA to output nY	see Figs 5 and 6	15	3.0 to 3.6	1.0	–	8.5	ns
				4.5 to 5.5	1.0	–	6.5	ns
		50	3.0 to 3.6	1.0	–	12	ns	
			4.5 to 5.5	1.0	–	8.5	ns	
$T_{amb} = -40\text{ to }+125\text{ }^\circ\text{C}$								
t_{PHL}/t_{PLH}	propagation delay input nA to output nY	see Figs 5 and 6	15	3.0 to 3.6	1.0	–	11.0	ns
				4.5 to 5.5	1.0	–	7.0	ns
		50	3.0 to 3.6	1.0	–	14.5	ns	
			4.5 to 5.5	1.0	–	9.5	ns	

Type 74AHCT3G04

GND = 0 V; $t_r = t_f \leq 3.0$ ns.

SYMBOL	PARAMETER	TEST CONDITIONS			MIN.	TYP.	MAX.	UNIT
		WAVEFORMS	C_L (pF)	V_{CC} (V)				
$T_{amb} = 25\text{ }^\circ\text{C}$								
t_{PHL}/t_{PLH}	propagation delay input nA to output nY	see Figs 5 and 6	15	4.5 to 5.5	–	–	6.7	ns
				5	–	3.4	–	ns
		50	4.5 to 5.5	–	–	7.7	ns	
			5	–	4.9	–	ns	
$T_{amb} = -40\text{ to }+85\text{ }^\circ\text{C}$								
t_{PHL}/t_{PLH}	propagation delay input nA to output nY	see Figs 5 and 6	15	4.5 to 5.5	1.0	–	7.5	ns
			50	4.5 to 5.5	1.0	–	8.5	ns

Inverter

74AHC3G04; 74AHCT3G04

SYMBOL	PARAMETER	TEST CONDITIONS			MIN.	TYP.	MAX.	UNIT
		WAVEFORMS	C _L (pF)	V _{CC} (V)				
T_{amb} = -40 to +125 °C								
t _{PHL} /t _{PLH}	propagation delay input nA to output nY	see Figs 5 and 6	15	4.5 to 5.5	1.0	-	8.5	ns
			50	4.5 to 5.5	1.0	-	10.0	ns

AC WAVEFORMS

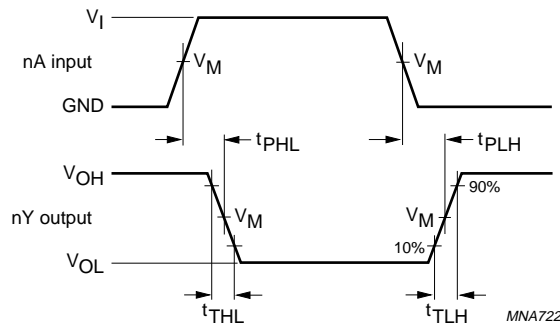

TYPE	V _I INPUT REQUIREMENTS	V _M INPUT	V _M OUTPUT
74AHC3G04	GND to V _{CC}	50% V _{CC}	50% V _{CC}
74AHCT3G04	GND to 3.0 V	1.5 V	50% V _{CC}

Fig.5 Input (nA) to output (nY) propagation delays.

Inverter

74AHC3G04; 74AHCT3G04

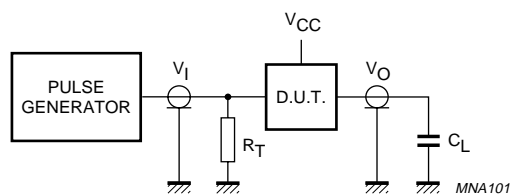

Definitions for test circuit:

C_L = load capacitance including jig and probe capacitance (see Chapter "AC characteristics").

R_T = termination resistance should be equal to the output impedance Z_0 of the pulse generator.

Fig.6 Load circuitry for switching times.

Inverter

74AHC3G04; 74AHCT3G04

PACKAGE OUTLINES

TSSOP8: plastic thin shrink small outline package; 8 leads; body width 3 mm; lead length 0.5 mm SOT505-2

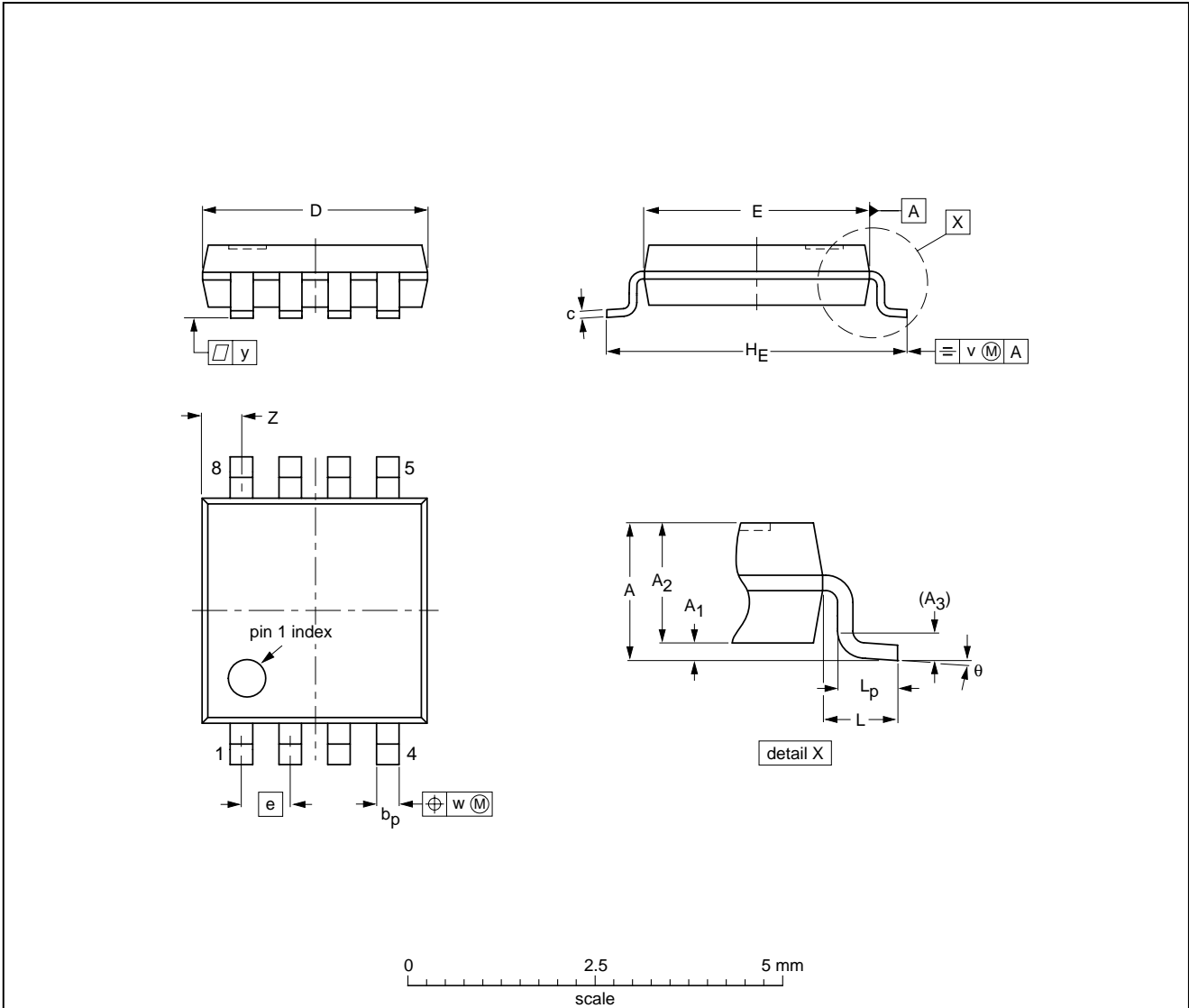

DIMENSIONS (mm are the original dimensions)

UNIT	A max.	A ₁	A ₂	A ₃	b _p	c	D ⁽¹⁾	E ⁽¹⁾	e	H _E	L	L _p	v	w	y	z ⁽¹⁾	θ
mm	1.1	0.15 0.00	0.95 0.75	0.25	0.38 0.22	0.18 0.08	3.1 2.9	3.1 2.9	0.65	4.1 3.9	0.5	0.47 0.33	0.2	0.13	0.1	0.70 0.35	8° 0°

Note

1. Plastic or metal protrusions of 0.15 mm maximum per side are not included.

OUTLINE VERSION	REFERENCES				EUROPEAN PROJECTION	ISSUE DATE
	IEC	JEDEC	JEITA			
SOT505-2		---				02-01-16

Inverter

74AHC3G04; 74AHCT3G04

VSSOP8: plastic very thin shrink small outline package; 8 leads; body width 2.3 mm

SOT765-1

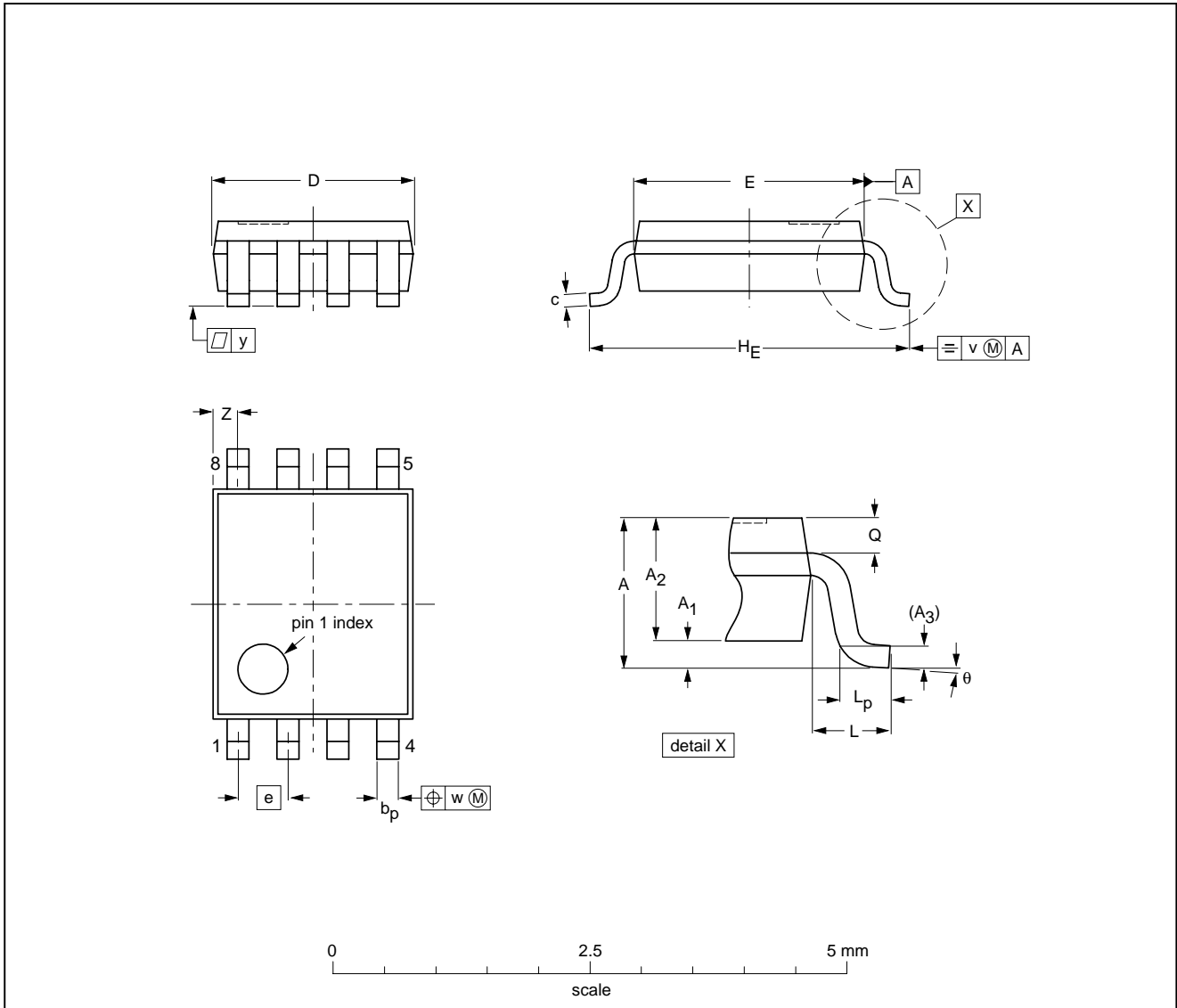

DIMENSIONS (mm are the original dimensions)

UNIT	A _{max.}	A ₁	A ₂	A ₃	b _p	c	D ⁽¹⁾	E ⁽²⁾	e	H _E	L	L _p	Q	v	w	y	Z ⁽¹⁾	θ
mm	1	0.15 0.00	0.85 0.60	0.12	0.27 0.17	0.23 0.08	2.1 1.9	2.4 2.2	0.5	3.2 3.0	0.4	0.40 0.15	0.21 0.19	0.2	0.13	0.1	0.4 0.1	8° 0°

Notes

1. Plastic or metal protrusions of 0.15 mm maximum per side are not included.
2. Plastic or metal protrusions of 0.25 mm maximum per side are not included.

OUTLINE VERSION	REFERENCES				EUROPEAN PROJECTION	ISSUE DATE
	IEC	JEDEC	JEITA			
SOT765-1		MO-187				02-06-07

Inverter

74AHC3G04; 74AHCT3G04

DATA SHEET STATUS

LEVEL	DATA SHEET STATUS ⁽¹⁾	PRODUCT STATUS ⁽²⁾⁽³⁾	DEFINITION
I	Objective data	Development	This data sheet contains data from the objective specification for product development. Philips Semiconductors reserves the right to change the specification in any manner without notice.
II	Preliminary data	Qualification	This data sheet contains data from the preliminary specification. Supplementary data will be published at a later date. Philips Semiconductors reserves the right to change the specification without notice, in order to improve the design and supply the best possible product.
III	Product data	Production	This data sheet contains data from the product specification. Philips Semiconductors reserves the right to make changes at any time in order to improve the design, manufacturing and supply. Relevant changes will be communicated via a Customer Product/Process Change Notification (CPCN).

Notes

1. Please consult the most recently issued data sheet before initiating or completing a design.
2. The product status of the device(s) described in this data sheet may have changed since this data sheet was published. The latest information is available on the Internet at URL <http://www.semiconductors.philips.com>.
3. For data sheets describing multiple type numbers, the highest-level product status determines the data sheet status.

DEFINITIONS

Short-form specification — The data in a short-form specification is extracted from a full data sheet with the same type number and title. For detailed information see the relevant data sheet or data handbook.

Limiting values definition — Limiting values given are in accordance with the Absolute Maximum Rating System (IEC 60134). Stress above one or more of the limiting values may cause permanent damage to the device. These are stress ratings only and operation of the device at these or at any other conditions above those given in the Characteristics sections of the specification is not implied. Exposure to limiting values for extended periods may affect device reliability.

Application information — Applications that are described herein for any of these products are for illustrative purposes only. Philips Semiconductors make no representation or warranty that such applications will be suitable for the specified use without further testing or modification.

DISCLAIMERS

Life support applications — These products are not designed for use in life support appliances, devices, or systems where malfunction of these products can reasonably be expected to result in personal injury. Philips Semiconductors customers using or selling these products for use in such applications do so at their own risk and agree to fully indemnify Philips Semiconductors for any damages resulting from such application.

Right to make changes — Philips Semiconductors reserves the right to make changes in the products - including circuits, standard cells, and/or software - described or contained herein in order to improve design and/or performance. When the product is in full production (status 'Production'), relevant changes will be communicated via a Customer Product/Process Change Notification (CPCN). Philips Semiconductors assumes no responsibility or liability for the use of any of these products, conveys no licence or title under any patent, copyright, or mask work right to these products, and makes no representations or warranties that these products are free from patent, copyright, or mask work right infringement, unless otherwise specified.

Philips Semiconductors – a worldwide company

Contact information

For additional information please visit <http://www.semiconductors.philips.com>. Fax: +31 40 27 24825

For sales offices addresses send e-mail to: sales.addresses@www.semiconductors.philips.com.

© Koninklijke Philips Electronics N.V. 2003

SCA75

All rights are reserved. Reproduction in whole or in part is prohibited without the prior written consent of the copyright owner.

The information presented in this document does not form part of any quotation or contract, is believed to be accurate and reliable and may be changed without notice. No liability will be accepted by the publisher for any consequence of its use. Publication thereof does not convey nor imply any license under patent- or other industrial or intellectual property rights.

Printed in The Netherlands

01/pp16

Date of release: 2003 Nov 06

Document order number: 9397 750 12118

Let's make things better.

**Philips
Semiconductors**



PHILIPS

This datasheet has been download from:

www.datasheetcatalog.com

Datasheets for electronics components.