



U74LVC574

Advance

CMOS IC

OCTAL EDGE-TRIGGERED D-TYPE FLIP-FLOPS WITH 3-STATE OUTPUTS

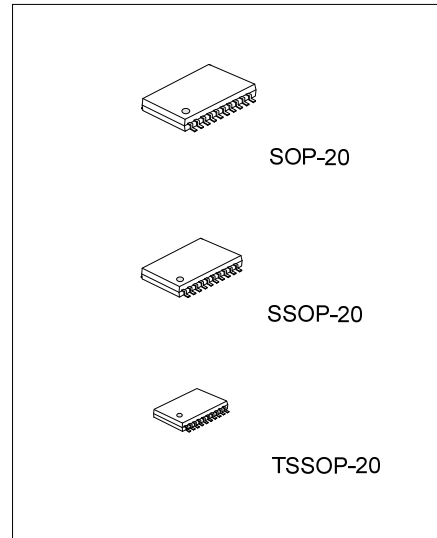

DESCRIPTION

The **U74LVC574** is a octal edge-triggered D-type flip-flop with 3-state outputs, and it has 8 channels.

FEATURES

- * Operate from 1.65V to 3.6V
- * Max t_{pd} of 7ns at 3.3 V
- * Typical $V_{OL} < 0.8V$ at $V_{CC}=3.3V, T_A=25^\circ C$
- * Typical $V_{OH} > 2V$ at $V_{CC}=3.3V, T_A=25^\circ C$
- * Power off disables outputs, permitting live insertion

ORDERING INFORMATION

Ordering Number		Package	Packing
Lead Free	Halogen Free		
U74LVC574L-P20-R	U74LVC574G-P20-R	TSSOP-20	Tape Reel
U74LVC574L-R20-R	U74LVC574G-R20-R	SSOP-20	Tape Reel
U74LVC574L-S20-R	U74LVC574G-S20-R	SOP-20	Tape Reel

<p>U74LVC574G-R20-R</p> <p>(1) Packing Type</p> <p>(2) Package Type</p> <p>(3) Green Package</p>	<p>(1) R: Tape Reel</p> <p>(2) P20: TSSOP-20, R20: SSOP-20, S20: SOP-20</p> <p>(3) G: Halogen Free and Lead Free, L: Lead Free</p>
--	--

MARKING

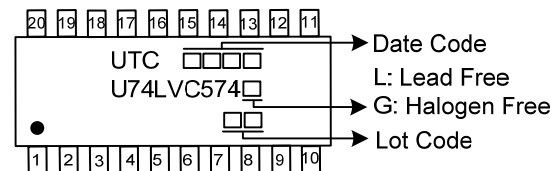

■ PIN CONFIGURATION

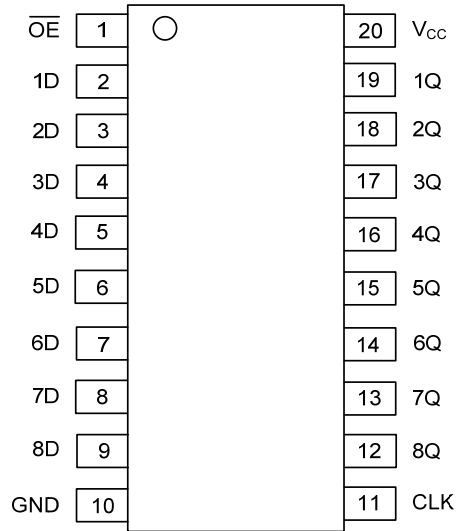

■ FUNCTION TABLE

INPUTS(OE)	INPUTS(CLK)	INPUTS(D)	OUTPUT(Q)
L	↑	H	H
L	↑	L	L
L	L	X	Q0
H	X	X	Z

Note: H: HIGH voltage level; L: LOW voltage level.

■ LOGIC SYMBOL

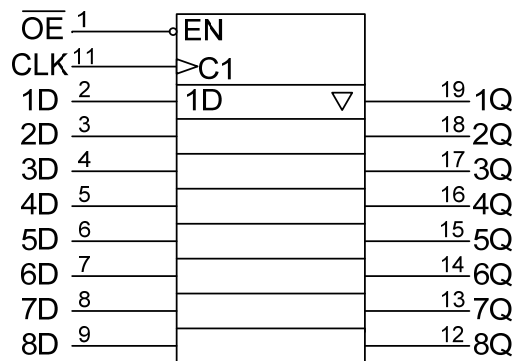

■ LOGIC DIAGRAM

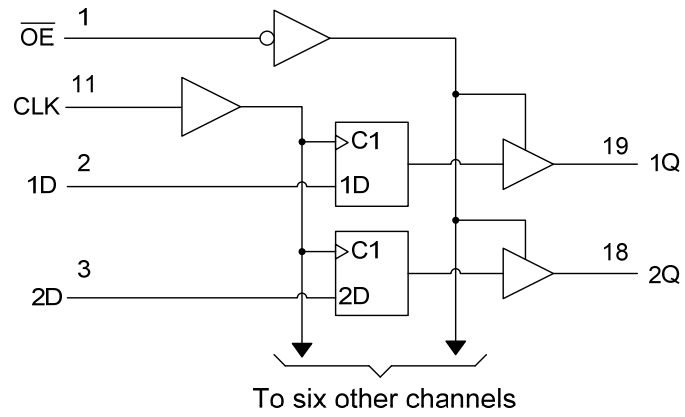

■ ABSOLUTE MAXIMUM RATING (T_A=25°C, unless otherwise specified)

PARAMETER	SYMBOL	RATINGS	UNIT
Supply Voltage	V _{CC}	-0.5 ~ 6.5	V
Input Voltage	V _{IN}	-0.5 ~ 6.5	V
Output Voltage	V _{OUT}	-0.5 ~ 6.5 (Note 2)	V
		-0.5 ~ V _{CC} +0.5 (Note 3)	V
V _{CC} or GND Current	I _{CC}	±100	mA
Output Current	I _{OUT}	±50	mA
Input Clamp Current	I _{IK}	-50	mA
Output Clamp Current	I _{OK}	-50	mA
Storage Temperature	T _{STG}	-65 ~ + 150	°C

- Notes: 1. Absolute maximum ratings are those values beyond which the device could be permanently damaged. Absolute maximum ratings are stress ratings only and functional device operation is not implied.
 2. Voltage range applied to any output in the high-impedance or power-off state.
 3. Voltage range applied to any output in the high or low state, and V_{CC} is provided in the recommended operating conditions table.

■ RECOMMENDED OPERATING CONDITIONS (T_A=25°C, unless otherwise specified)

PARAMETER	SYMBOL	TEST CONDITIONS	MIN	TYP	MAX	UNIT
Supply Voltage	V _{CC}	Operating	1.65		3.6	V
		Data retention only	1.5			V
High-level Input Voltage	V _{IH}	V _{CC} =1.65V to 1.95V	0.65×V _{CC}			V
		V _{CC} =2.3V to 2.7V	1.7			V
		V _{CC} =2.7V to 3.6V	2			V
Low-level Input Voltage	V _{IL}	V _{CC} =1.65V to 1.95V			0.35×V _{CC}	V
		V _{CC} =2.3V to 2.7V			0.7	V
		V _{CC} =2.7V to 3.6V			0.8	V
Input Voltage	V _{IN}		0		5.5	V
Output Voltage	V _{OUT}	High or low state	0		V _{CC}	V
		3 state	0		5.5	V
High-level Output Current	I _{OH}	V _{CC} =1.65V			-4	mA
		V _{CC} =2.3V			-8	mA
		V _{CC} =2.7V			-12	mA
		V _{CC} =3V			-24	mA
Low-level Output Current	I _{OL}	V _{CC} =1.65V			4	mA
		V _{CC} =2.3V			8	mA
		V _{CC} =2.7V			12	mA
		V _{CC} =3V			24	mA
Input Rise or Fall Times	t _R , t _F		0		6	ns/V
Operating Temperature	T _A		-40		+125	°C

■ ELECTRICAL CHARACTERISTICS (T_A=25°C, unless otherwise specified)

PARAMETER	SYMBOL	TEST CONDITIONS	MIN	TYP (Note 1)	MAX	UNIT
Output Voltage High-Level	V _{OH}	V _{CC} =1.65~3.6V, I _{OH} =-100μA	V _{CC} -0.2			V
		V _{CC} =1.65V, I _{OH} =-4mA	1.2			V
		V _{CC} =2.3V, I _{OH} =-8mA	1.7			V
		V _{CC} =2.7V, I _{OH} =-12mA	2.2			V
		V _{CC} =3V, I _{OH} =-12mA	2.4			V
		V _{CC} =3V, I _{OH} =-24mA	2.2			V
Output Voltage Low-Level	V _{OL}	V _{CC} =1.65~3.6V, I _{OL} =100μA			0.2	V
		V _{CC} =1.65V, I _{OL} =4mA			0.45	V
		V _{CC} =2.3V, I _{OL} =8mA			0.7	V
		V _{CC} =2.7V, I _{OL} =12mA			0.4	V
		V _{CC} =3V, I _{OL} =24mA			0.55	V
Input Leakage Current	I _{I(LEAK)}	V _{CC} =3.6V, V _{IN} =0 to 5.5V			±5	μA
Power OFF Leakage Current	I _{OFF}	V _{CC} =0V, V _{IN} or V _{OUT} =5.5V			±10	μA
Disable Output Leakage Current	I _{OZ}	V _{CC} =3.6V, V _{OUT} =0 to 5.5V			±10	μA
Quiescent Supply Current	I _Q	V _{CC} =3.6V, V _{IN} =V _{CC} or GND, I _{OUT} =0			10	μA
		V _{CC} =3.6V, 3.6V≤V _{IN} ≤5.5V, I _{OUT} =0(Note 2)			10	μA
Additional Quiescent Supply Current	Δ I _Q	V _{CC} =2.7~3.6V, One input at V _{CC} -0.6V, Other inputs at V _{CC} or GND			500	μA
Input Capacitance	C _I	V _{CC} =3.3V, V _{IN} =V _{CC} or GND		4		pF
Output Capacitance	C _O	V _{CC} =3.3V, V _{OUT} =V _{CC} or GND		5.5		pF

Notes: 1. V_{CC}=3.3V, T_A=25°C

2. This applies in the disabled state only.

■ SWITCHING CHARACTERISTICS

PARAMETER	SYMBOL	TEST CONDITIONS	MIN	TYP	MAX	UNIT
Propagation delay from input (CLK) to output (Q)	t _{PLH} /t _{PHL}	V _{CC} =2.7V			8	ns
		V _{CC} =3.3V±0.3V	2.2		7	ns
Output enable time from input (\overline{OE}) to output (Q)	t _{PZL} /t _{PZH}	V _{CC} =2.7V			8.5	ns
		V _{CC} =3.3V±0.3V	1.5		7.5	ns
Output disable time from input (\overline{OE}) to output (Q)	t _{PLZ} /t _{PHZ}	V _{CC} =2.7V			7	ns
		V _{CC} =3.3V±0.3V	1.7		6.4	ns
Maximum Clock Frequency	f _{MAX}	V _{CC} =2.7V	150			MHz
		V _{CC} =3.3V±0.3V	150			MHz
Pulse Width	t _W	V _{CC} =2.7V	3.3			ns
		V _{CC} =3.3V±0.3V	3.3			ns
Setup Time	t _{SU}	V _{CC} =2.7V	2			ns
		V _{CC} =3.3V±0.3V	2			ns
Hold Time	t _H	V _{CC} =2.7V	1.5			ns
		V _{CC} =3.3V±0.3V	1.5			ns

■ OPERATING CHARACTERISTICS (T_A=25°C, unless otherwise specified)

PARAMETER	SYMBOL	TEST CONDITIONS	MIN	TYP	MAX	UNIT
Power Dissipation Capacitance	C _{PD}	OE=0, f=10MHz, V _{CC} =3.3V±0.3V		43		pF
		OE=1, f=10MHz, V _{CC} =3.3V±0.3V		15		pF

■ TEST CIRCUIT AND WAVEFORMS

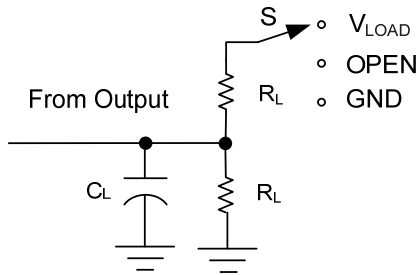

TEST CIRCUIT

V_{CC}	V_{IN}	t_{PLZ}/t_{PZL} (V_{LOAD})	t_{PLH}/t_{PHL}	t_{PHZ}/t_{PZH}	C_L	R_L (Note 1)	ΔV
$1.8V \pm 0.15V$	V_{CC}	$2 \times V_{CC}$	OPEN	OPEN	30pF	1k Ω	0.15V
$2.5V \pm 0.2V$	V_{CC}	$2 \times V_{CC}$	OPEN	GND	30pF	500 Ω	0.15V
2.7V	2.7V	6V	OPEN	GND	50pF	500 Ω	0.3V
$3.3V \pm 0.3V$	2.7V	6V	OPEN	GND	50pF	500 Ω	0.3V

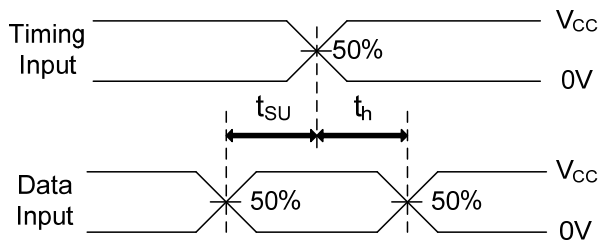

SETUP TIME AND HOLD TIME

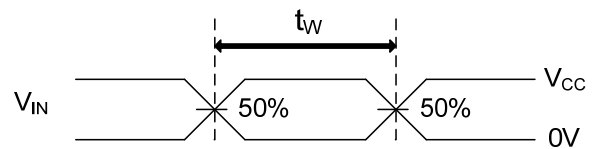

PULSE WIDTH

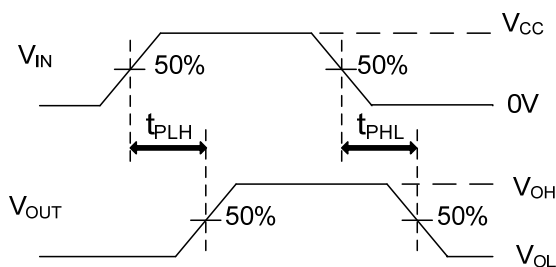

PROPAGATION DELAY TIMES

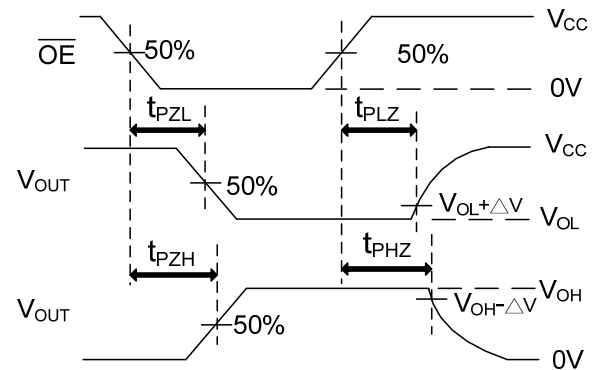

ENABLE AND DISABLE TIMES

Note: 1. C_L includes probe and jig capacitance.

Note: 2. $PRR \leq 10MHz$, $Z_O = 50\Omega$, $t_{THL} \leq 2ns$, $t_{TLH} \leq 2ns$.

UTC assumes no responsibility for equipment failures that result from using products at values that exceed, even momentarily, rated values (such as maximum ratings, operating condition ranges, or other parameters) listed in products specifications of any and all UTC products described or contained herein. UTC products are not designed for use in life support appliances, devices or systems where malfunction of these products can be reasonably expected to result in personal injury. Reproduction in whole or in part is prohibited without the prior written consent of the copyright owner. UTC reserves the right to make changes to information published in this document, including without limitation specifications and product descriptions, at any time and without notice. This document supersedes and replaces all information supplied prior to the publication hereof.