

LR6311

3 Watt Mono Filter-Free Class-D Audio Power Amplifier

Features

- Efficiency With an 8- Ω Speaker:
 - 88% at 400 mW
 - 80% at 100 mW
- 2.6mA Quiescent Current
- 0.4 μ A Shutdown Current
- Optimized PWM Output Stage Eliminates LC Output Filter
- Internally Generated 250-kHz Switching Frequency Eliminates Capacitor and Resistor
- Improved PSRR (-75 dB) and Wide Supply Voltage (2.5 V to 5.5 V) Eliminates Need for a Voltage Regulator
- Fully Differential Design Reduces RF Rectification and Eliminates Bypass Capacitor
- Improved CMRR Eliminates Two Input Coupling Capacitors
- Available in space-saving package: 9-bump WLCSP

General Description

ss-D audio power amplifier in

The LR6311 is a 3-W high efficiency filter-free class-D audio power amplifier in a wafer chip scale package (WCSP) that requires only three external components.

Features like 88% efficiency, -75 dB PSRR, and improved RF-rectification immunity make the LR6311 ideal for cellular handsets. In cellular handsets, the earpiece, speaker phone, and melody ringer can each be driven by the LR6311.

Applications

- Mobile phone、PDA
- MP3/4、PMP
- Portable electronic devices

Pin Diagrams

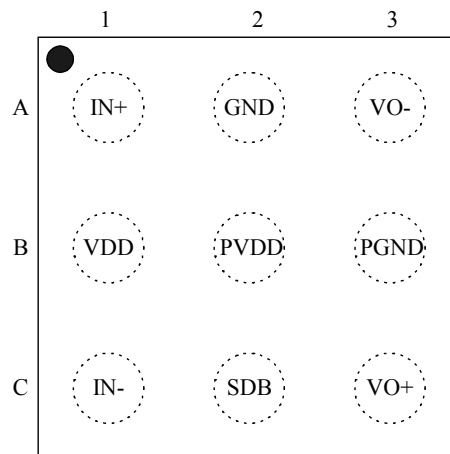

top view

Pin Description

| Pin # | Name | Description |
|-------|------|--------------------------------|
| A1 | IN+ | Positive differential input |
| A2 | GND | Power Ground |
| A3 | VO- | Negative BTL output |
| B1 | VDD | Power Supply |
| B2 | PVDD | Power Supply |
| B3 | PGND | Power Ground |
| C1 | IN- | Negative differential input |
| C2 | SDB | Shutdown terminal (low active) |
| C3 | VO+ | Positive BTL output |

Function Block Diagram

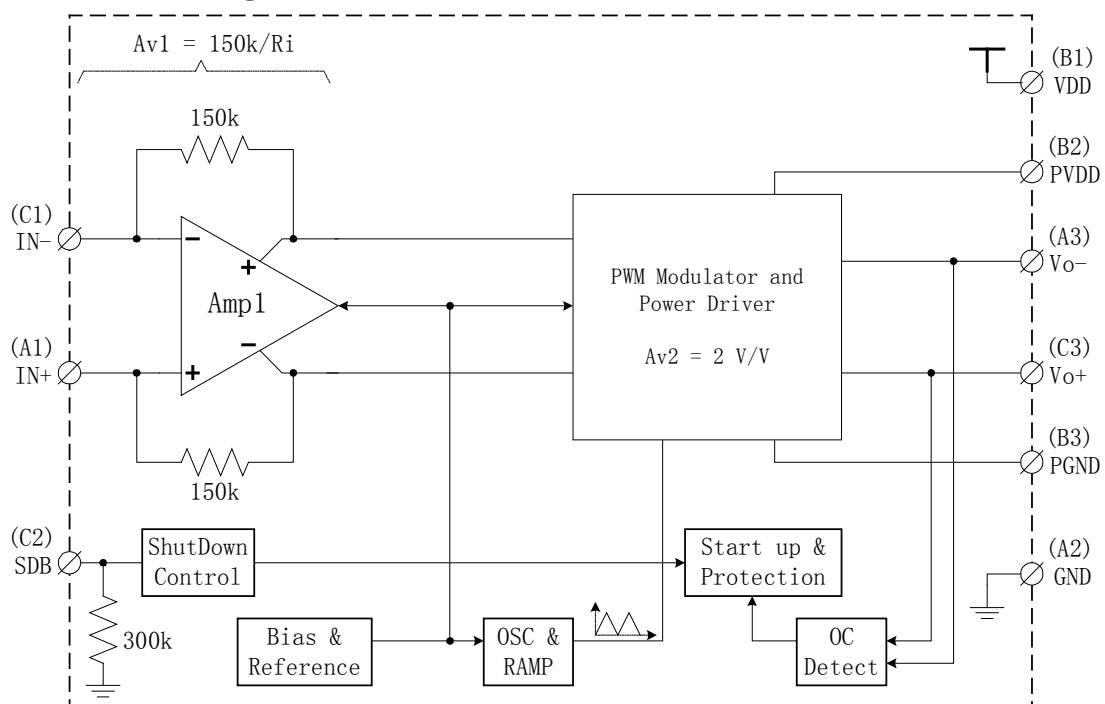

Notes: Total Voltage Gain = $Av1 \times Av2 = 2 \times \frac{150k}{R_i}$

Figure 1. Function Block Diagram

Application Circuit

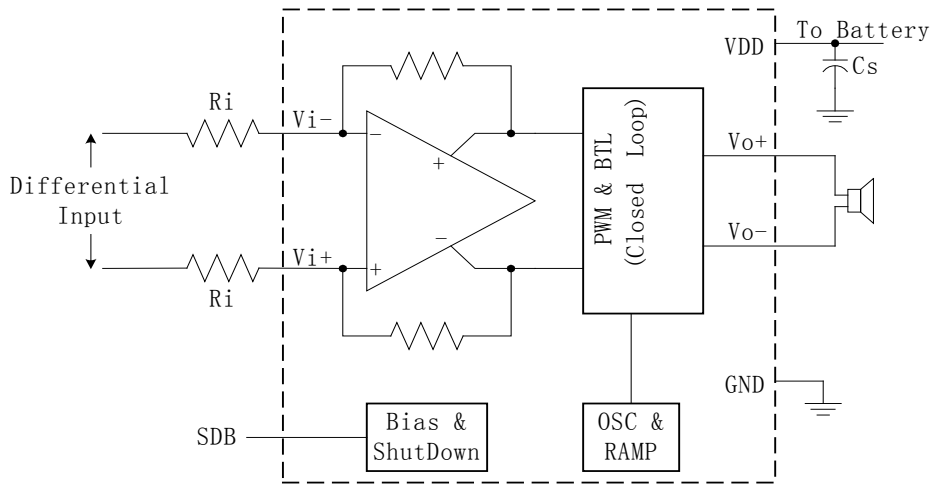

Figure 2. LR6311 Application Schematic With Differential Input

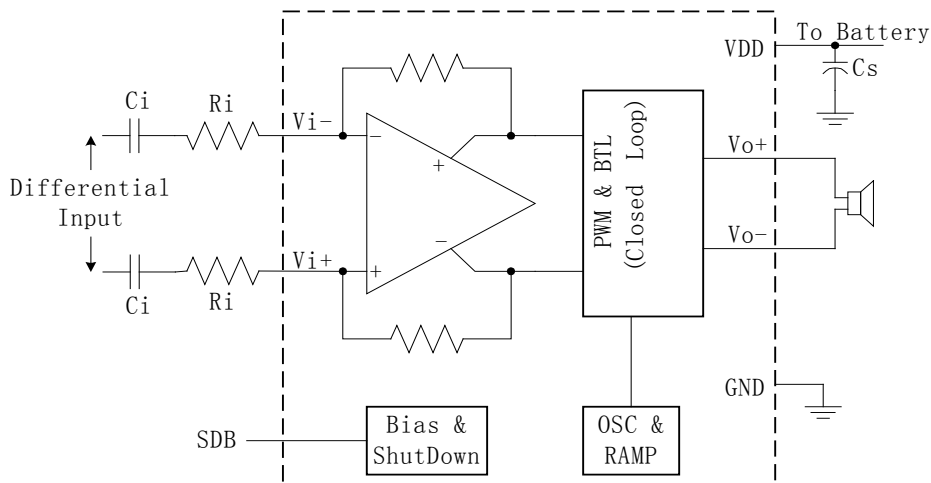

Figure 3. LR6311 Application Schematic With Differential Input and Input Capacitors

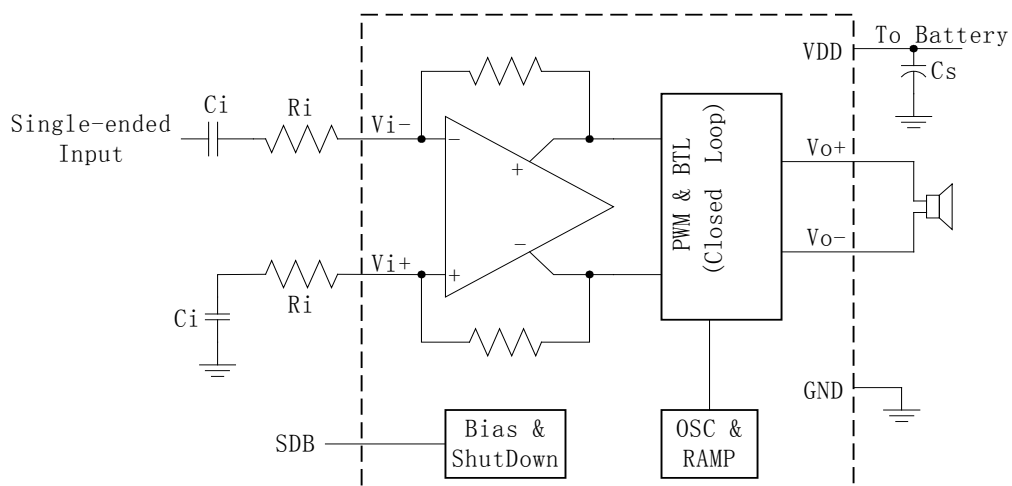

Figure 4. LR6311 Application Schematic With Single-Ended Input

Electrical Characteristics

The following specifications apply for the circuit shown in Figure 5.

$T_A = 25^\circ\text{C}$, unless otherwise specified.

| Symbol | Parameter | Conditions | Spec | | | Units |
|--------------|------------------------------------|--|--------------------|--------------------|--------------------|---------------|
| | | | Min. | Typ. | Max. | |
| I_{SD} | Shutdown Current | $V_{IN}=0V, V_{SDB}=0V$, No Load | | 0.4 | 2 | μA |
| I_Q | Quiescent Current | $V_{DD} = 2.5V, V_{IN} = 0V$, No Load | | 2.0 | | mA |
| | | $V_{DD} = 3.6V, V_{IN} = 0V$, No Load | | 2.6 | | |
| | | $V_{DD} = 5.5V, V_{IN} = 0V$, No Load | | 3.0 | 8 | |
| $ V_{OS} $ | Output Offset Voltage | $V_{IN} = 0V, A_V = 2V/V$, $V_{DD} = 2.5V$ to $5.5V$ | | 2 | 25 | mV |
| PSRR | Power Supply Rejection Ratio | $V_{DD} = 2.5V$ to $5.5V$ | | -75 | | dB |
| CMRR | Common Mode Rejection Ratio | $V_{DD} = 2.5V$ to $5.5V$, $V_{IC} = V_{DD}/2$ to $0.5V$, $V_{IC} = V_{DD}/2$ to $V_{DD} - 0.8V$ | | -68 | | dB |
| f_{SW} | Modulation frequency | $V_{DD} = 2.5V$ to $5.5V$ | 200 | 250 | 300 | kHz |
| A_V | Voltage gain | $V_{DD} = 2.5V$ to $5.5V$ | $\frac{285k}{R_I}$ | $\frac{300k}{R_I}$ | $\frac{315k}{R_I}$ | V/V |
| R_{SDB} | Resistance from SDB to GND | | | 300 | | $k\Omega$ |
| Z_I | Input impedance | | 142 | 150 | 158 | $k\Omega$ |
| T_{WU} | Wake-up time from shutdown | $V_{DD} = 3.6V$ | | 1 | | mS |
| $r_{DS(on)}$ | Drain-Source resistance (on-state) | $V_{DD} = 2.5V$ | | 700 | | m Ω |
| | | $V_{DD} = 3.6V$ | | 500 | | |
| | | $V_{DD} = 5.5V$ | | 400 | | |
| | | | | | | |

Operating Characteristics

$V_{DD} = 5V, R_I = 150k\Omega, T_A = 25^\circ\text{C}$, unless otherwise specified.

| Symbol | Parameter | Conditions | Spec | | | Units |
|--------|-----------------------------------|--|------|------|------|-------|
| | | | Min. | Typ. | Max. | |
| P_O | Output Power | THD+N=10%, $f=1\text{KHz}$, $R_L = 4\Omega$ | | 3.0 | | W |
| | | THD+N=1%, $f=1\text{KHz}$, $R_L = 4\Omega$ | | 2.4 | | |
| | | THD+N=10%, $f=1\text{KHz}$, $R_L = 8\Omega$ | | 1.7 | | |
| | | THD+N=1%, $f=1\text{KHz}$, $R_L = 8\Omega$ | | 1.4 | | |
| THD+N | Total Harmonic Distortion + Noise | $P_o=1.0W_{rms}$, $f=1\text{KHz}$, $R_L = 8\Omega$ | | 0.19 | | % |
| SNR | Signal-to-Noise ratio | $V_{DD}=5V, P_o=1.0W_{rms}, R_L = 8\Omega$ | | 97 | | dB |

$V_{DD} = 3.6V, R_I = 150k\Omega, T_A = 25^\circ\text{C}$, unless otherwise specified.

| Symbol | Parameter | Conditions | Spec | | | Units |
|-----------|-----------------------------------|--|--------------|------|------|---------------------|
| | | | Min. | Typ. | Max. | |
| P_O | Output Power | THD+N=10%, $f=1\text{KHz}$, $R_L = 4\Omega$ | | 1.5 | | W |
| | | THD+N=1%, $f=1\text{KHz}$, $R_L = 4\Omega$ | | 1.2 | | |
| | | THD+N=10%, $f=1\text{KHz}$, $R_L = 8\Omega$ | | 0.9 | | |
| | | THD+N=1%, $f=1\text{KHz}$, $R_L = 8\Omega$ | | 0.7 | | |
| THD+N | Total Harmonic Distortion + Noise | $P_o=0.5W_{rms}$, $f=1\text{KHz}$, $R_L = 8\Omega$ | | 0.19 | | % |
| K_{SVR} | Supply ripple rejection ratio | $V_{DD} = 3.6V$, input ac-grounded with $C_I = 2\mu\text{F}$ $f=217\text{Hz}$, $V(\text{Ripple})=200\text{mV}_{PP}$ | | -68 | | dB |
| V_n | Output voltage noise | $V_{DD} = 3.6V$, input ac-grounded with $C_I = 2\mu\text{F}$, $f=20\sim 20\text{kHz}$ | No weighting | 48 | | μV_{RMS} |
| | | | A weighting | 36 | | |
| CMRR | Common Mode Rejection Ratio | $V_{DD} = 3.6V, V_{IC} = 1 V_{PP}, f=217\text{Hz}$ | | -70 | | dB |

$V_{DD} = 2.5V, R_I = 150k\Omega, T_A = 25^\circ\text{C}$, unless otherwise specified.

| | Parameter | Conditions | Spec | Units |
|--|-----------|------------|------|-------|
|--|-----------|------------|------|-------|

| Symbol | Parameter | Conditions | Spec | | | Units |
|--------|-----------------------------------|--|------|------|------|-------|
| | | | Min. | Typ. | Max. | |
| | | THD+N=10%, f=1KHz, $R_L = 4\Omega$ | | 0.7 | | |
| | | THD+N=1%, f=1KHz, $R_L = 4\Omega$ | | 0.55 | | |
| | | THD+N=10%, f=1KHz, $R_L = 8\Omega$ | | 0.4 | | |
| | | THD+N=1%, f=1KHz, $R_L = 8\Omega$ | | 0.3 | | |
| THD+N | Total Harmonic Distortion + Noise | $P_o=0.2W_{rms}$, f=1kHz, $R_L = 8\Omega$ | | 0.19 | | % |

Test Circuit

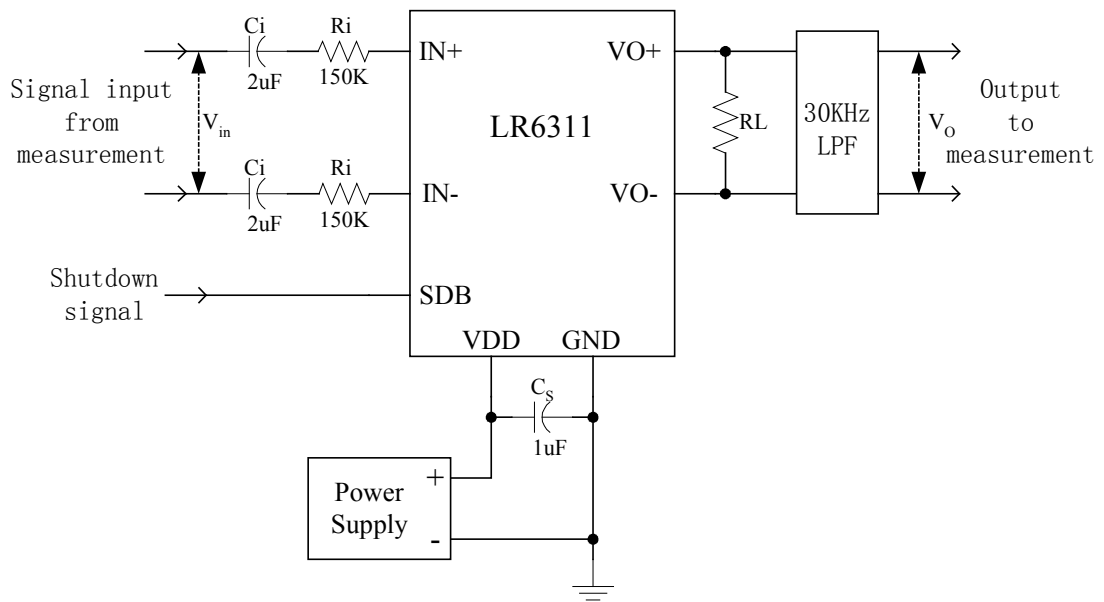

Figure 5. LR6311 test set up circuit

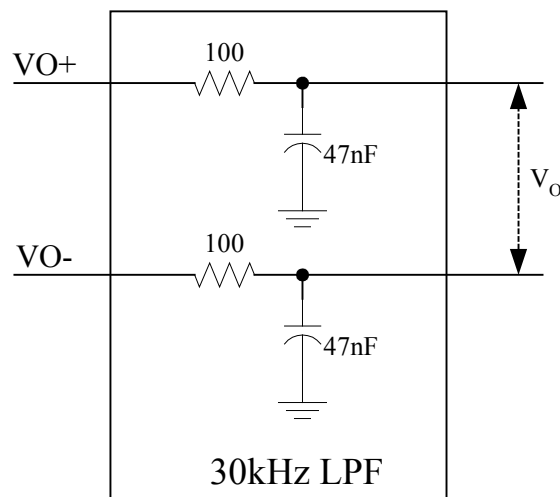

Figure 6. 30-kHz LPF for LR6311 test

- Notes: 1>. C_s should be placed as close as possible to VDD/GND pad of the device
 2>. C_i should be shorted for any Common-Mode input voltage measurement

- 3>. A 33uH inductor should be used in series with R_L for efficiency measurement
- 4>. The 30 kHz LPF (shown in figure 5) is required even if the analyzer has an internal LPF

Component Recommended

Due to the weak noise immunity of the single-ended input application, the differential input application should be used whenever possible. The typical component values are listed in the table:

| R_I | C_I | C_S |
|-------|--------|-------|
| 150 k | 3.3 nF | 1 uF |

- (1) C_I should have a tolerance of $\pm 10\%$ or better to reduce impedance mismatch.
- (2) Use 1% tolerance resistors or better to keep the performance optimized, and place the R_I close to the device to limit noise injection on the high-impedance nodes.

Input Resistors (R_I) & Capacitors (C_I)

The input resistors (R_I) set the total voltage gain of the amplifier according to Eq1

$$Gain = \frac{2 \times 150k\Omega}{R_I} \left(\frac{V}{V} \right) \quad Eq1$$

The input resistor matching directly affects the CMRR, PSRR, and the second harmonic distortion cancellation.

If a differential signal source is used, and the signal is biased from 0.5V ~ V_{DD} -0.8V (shown in Figure2), the input capacitor (C_I) is not required.

If the input signal is not biased within the recommended common-mode input range in differential input application (shown in Figure3), or in a single-ended input application (shown in Figure4), the input coupling capacitors are required.

If the input coupling capacitors are used, the R_I and C_I form a high-pass filter (HPF). The corner frequency (f_c) of the HPF can be calculated by Eq2

$$f_c = \frac{1}{2\pi \cdot R_I \cdot C_I} \quad (Hz) \quad Eq2$$

Decoupling Capacitor (C_S)

A good low equivalent-series-resistance (ESR) ceramic capacitor (C_S), used as power supply decoupling capacitor (C_S), is required for high power supply rejection (PSRR), high efficiency and low total harmonic distortion (THD). Typically C_S is 1uF, placed as close as possible to the device VDD pin.

Typical Performance Characteristics

Audio Precision

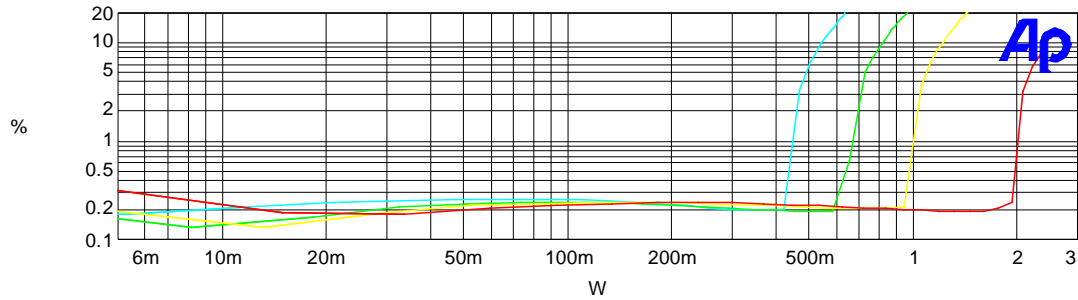

| Sweep | Trace | Color | Line Style | Thick | Data | Axis | Comment |
|-------|-------|--------|------------|-------|-----------------------|------|---------|
| 1 | 1 | Cyan | Solid | 1 | Analyzer.TH+N Ratio B | Left | 2.5v |
| 2 | 1 | Green | Solid | 1 | Analyzer.TH+N Ratio B | Left | 3v |
| 3 | 1 | Yellow | Solid | 1 | Analyzer.TH+N Ratio B | Left | 3.6v |
| 4 | 1 | Red | Solid | 1 | Analyzer.TH+N Ratio B | Left | 5v |

Figure7 THDN vs P_O (R_L=40ohm, f=1kHz, Gain=2)

Audio Precision

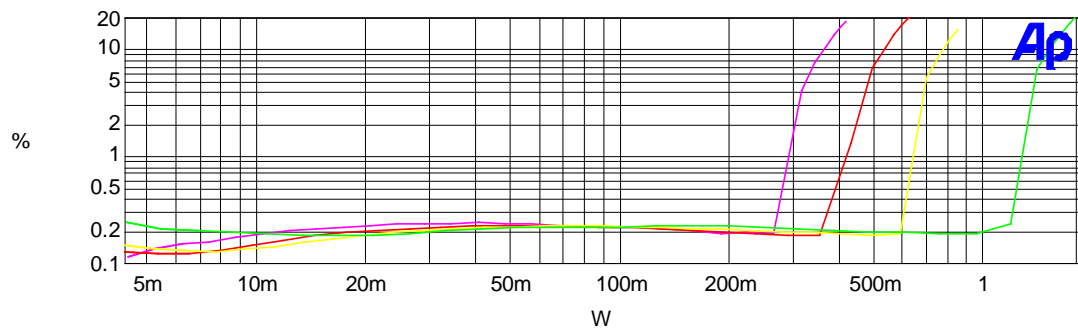

| Sweep | Trace | Color | Line Style | Thick | Data | Axis | Comment |
|-------|-------|---------|------------|-------|------------------------|------|---------|
| 1 | 1 | Magenta | Solid | 1 | .Analyzer.TH+N Ratio B | Left | 2.5V |
| 2 | 1 | Red | Solid | 1 | .Analyzer.TH+N Ratio B | Left | 3V |
| 3 | 1 | Yellow | Solid | 1 | .Analyzer.TH+N Ratio B | Left | 3.6V |
| 4 | 1 | Green | Solid | 1 | .Analyzer.TH+N Ratio B | Left | 5V |

Figure8 THDN vs P_O (R_L=80ohm, f=1kHz, Gain=2)

Audio Precision

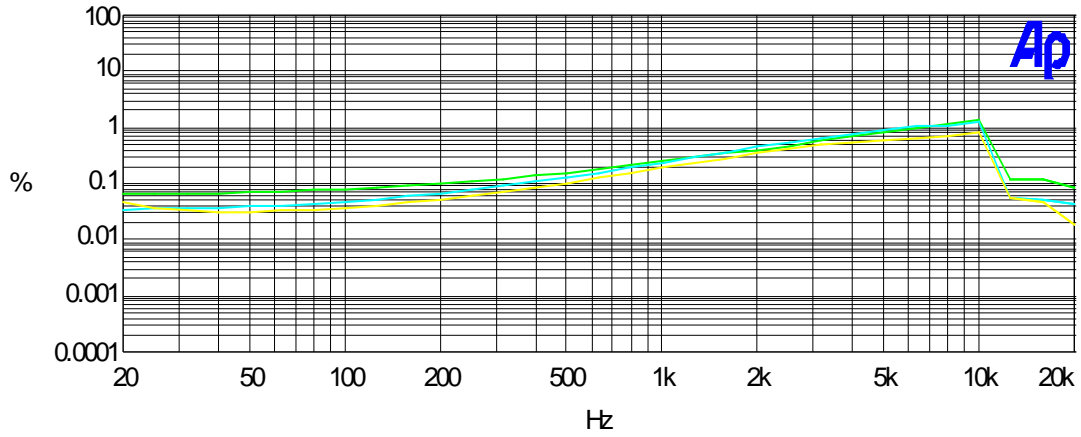

| Sweep | Trace | Color | Line Style | Thick | Data | Axis | Comment |
|-------|-------|--------|------------|-------|-----------------------|------|----------|
| 1 | 1 | Green | Solid | 1 | Analyzer.TH+N Ratio B | Left | Po=25mW |
| 2 | 1 | Cyan | Solid | 1 | Analyzer.TH+N Ratio B | Left | Po=250mW |
| 3 | 1 | Yellow | Solid | 1 | Analyzer.TH+N Ratio B | Left | Po=1w |

Figure9 THDN vs Frequency ($V_{DD}=5V$ $R_L=8ohm$ Gain=2 $C_I=2uF$)

Audio Precision

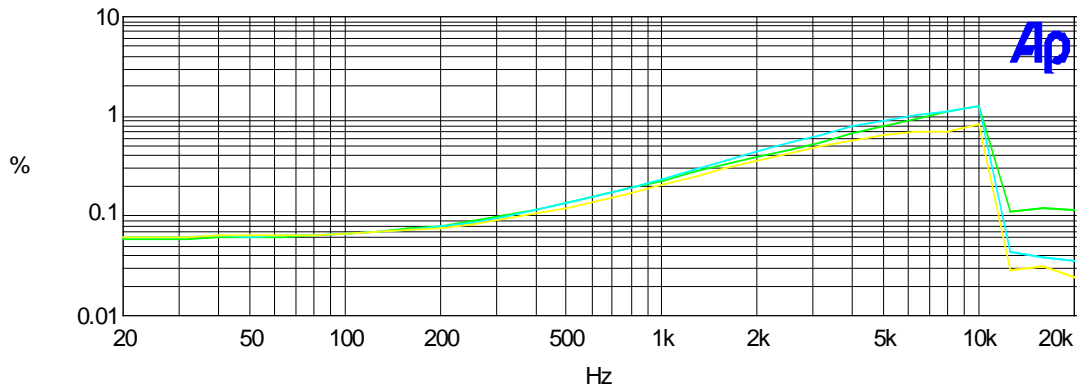

| Sweep | Trace | Color | Line Style | Thick | Data | Axis | Comment |
|-------|-------|--------|------------|-------|-----------------------|------|---------|
| 1 | 1 | Green | Solid | 1 | Analyzer.TH+N Ratio B | Left | |
| 2 | 1 | Cyan | Solid | 1 | Analyzer.TH+N Ratio B | Left | |
| 3 | 1 | Yellow | Solid | 1 | Analyzer.TH+N Ratio B | Left | |

Figure10 THDN vs Frequency ($V_{DD}=3.6V$ $R_L=8ohm$ Gain=2 $C_I=2uF$)

Audio Precision

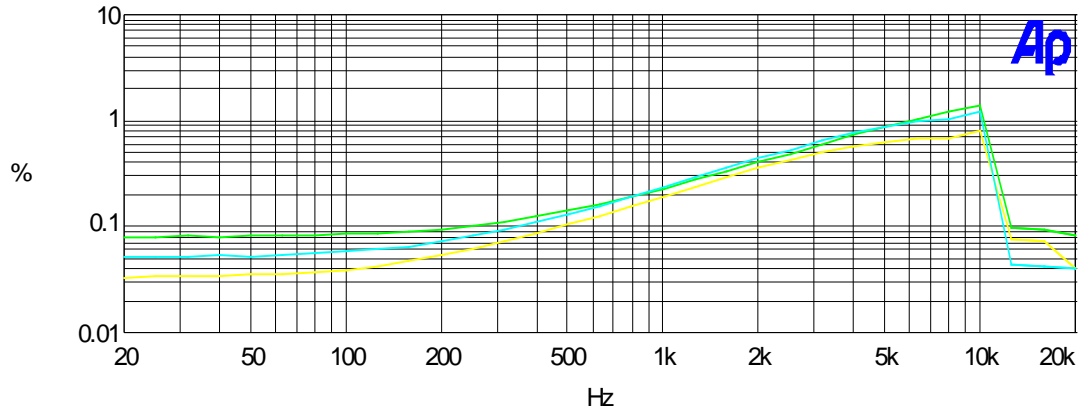

| Sweep | Trace | Color | Line Style | Thick | Data | Axis | Comment |
|-------|-------|--------|------------|-------|-----------------------|------|----------|
| 1 | 1 | Green | Solid | 1 | Analyzer.TH+N Ratio B | Left | Po=15mW |
| 2 | 1 | Cyan | Solid | 1 | Analyzer.TH+N Ratio B | Left | Po=75mW |
| 3 | 1 | Yellow | Solid | 1 | Analyzer.TH+N Ratio B | Left | po=200mW |

Figure11 THDN vs Frequency ($V_{DD}=2.5V$ $R_L=8ohm$ Gain=2 $C_1=2uF$)

Audio Precision

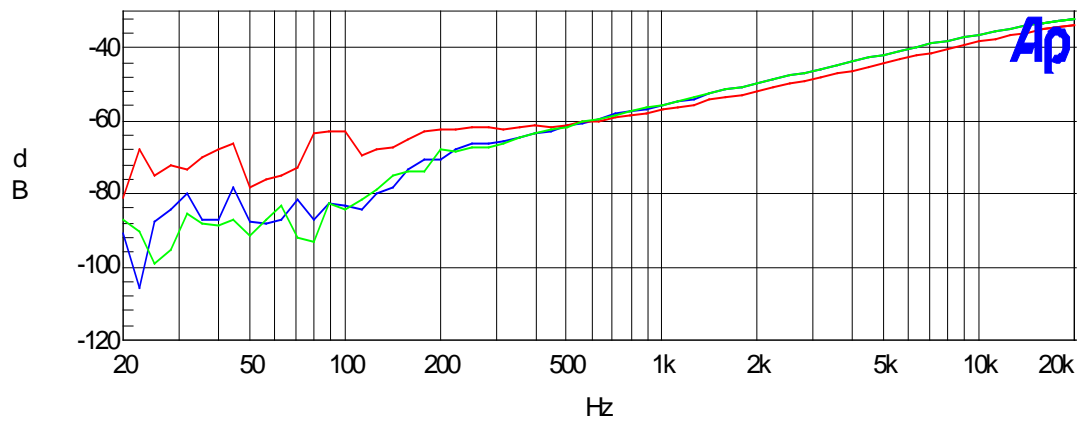

| Sweep | Trace | Color | Line Style | Thick | Data | Axis | Comment |
|-------|-------|-------|------------|-------|----------------------|------|---------|
| 1 | 1 | Blue | Solid | 1 | Analyzer.Crosstalk B | Left | 5V |
| 2 | 1 | Green | Solid | 1 | Analyzer.Crosstalk B | Left | 3.6V |
| 3 | 1 | Red | Solid | 1 | Analyzer.Crosstalk B | Left | 2.5V |

Figure12 PSRR vs Frequency ($R_L=4ohm$, Input ac-grounded)

Audio Precision

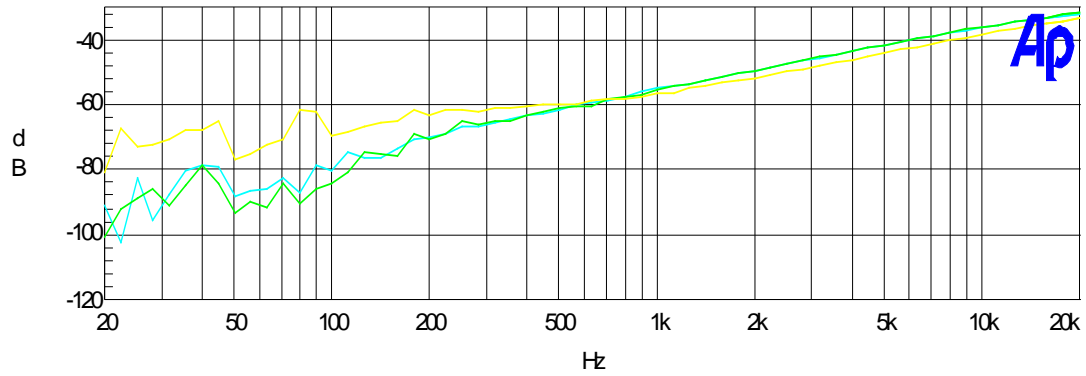

| Sweep | Trace | Color | Line Style | Thick | Data | Axis | Comment |
|-------|-------|--------|------------|-------|----------------------|------|---------|
| 1 | 1 | Cyan | Solid | 1 | Analyzer.Crosstalk B | Left | 5v |
| 2 | 1 | Green | Solid | 1 | Analyzer.Crosstalk B | Left | 3.6v |
| 3 | 1 | Yellow | Solid | 1 | Analyzer.Crosstalk B | Left | 2.5v |

Figure13 PSRR vs Frequency ($R_L=8\text{ohm}$, Input ac-grounded)

Audio Precision

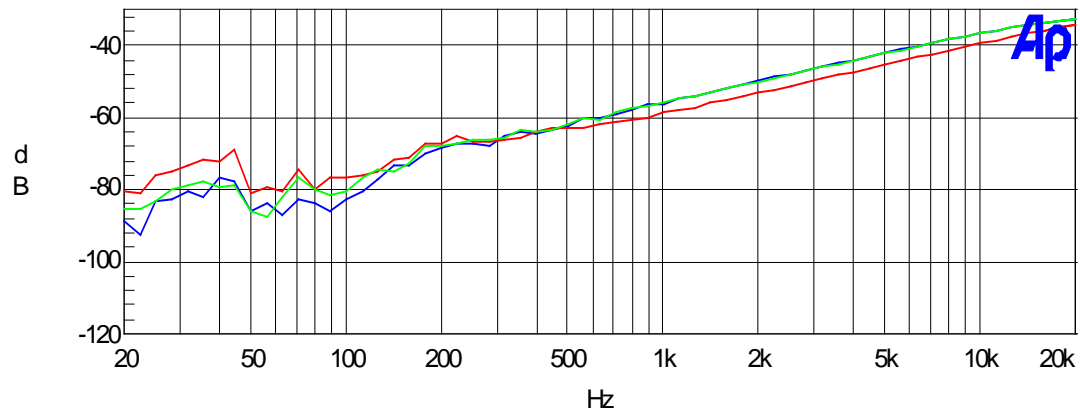

| Sweep | Trace | Color | Line Style | Thick | Data | Axis | Comment |
|-------|-------|-------|------------|-------|----------------------|------|---------|
| 1 | 1 | Blue | Solid | 1 | Analyzer.Crosstalk B | Left | 5V |
| 2 | 1 | Green | Solid | 1 | Analyzer.Crosstalk B | Left | 3.6V |
| 3 | 1 | Red | Solid | 1 | Analyzer.Crosstalk B | Left | 2.5V |

Figure14 PSRR vs Frequency ($R_L=8\text{ohm}$, Input floating)

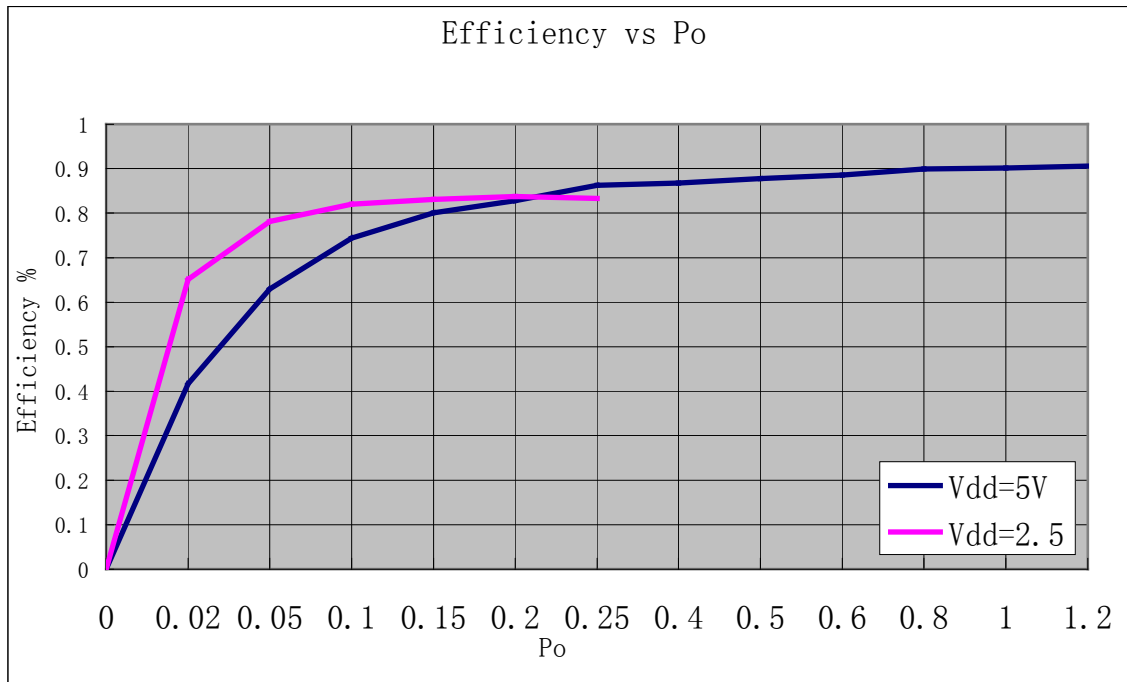

Figure15 GSM Power Supply Rejection vs Time

(RL=8 Ω +33uH)

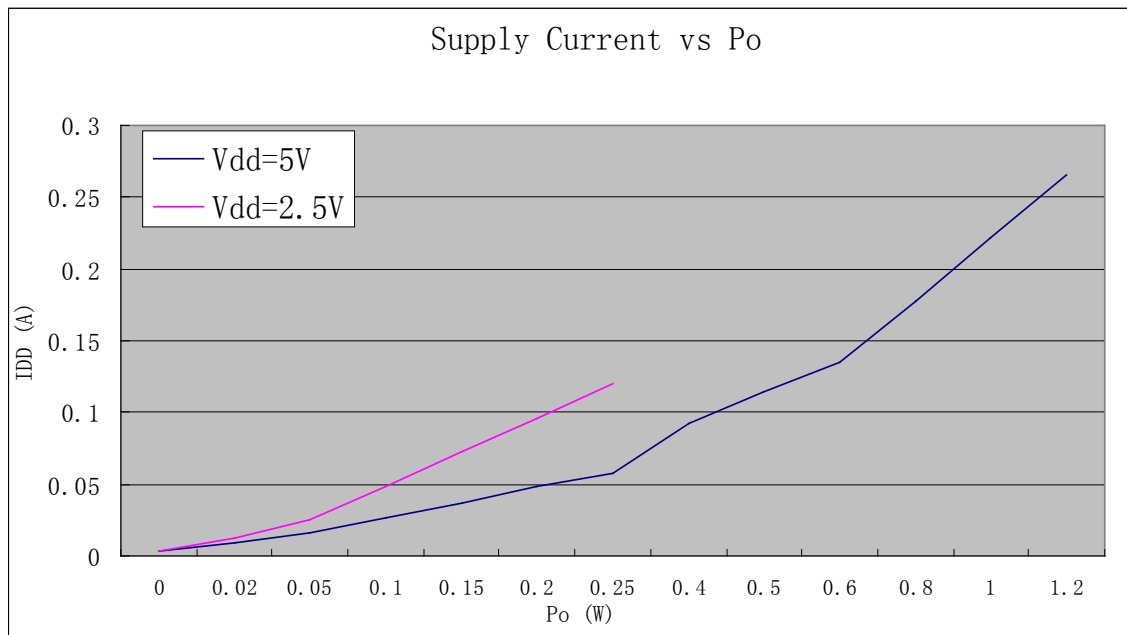
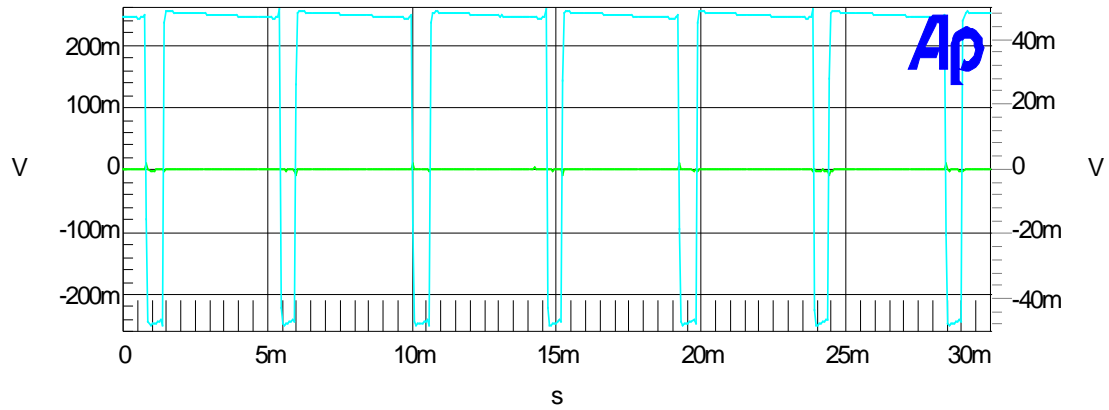

Figure16 Supply Current vs Output Power (RL=8 Ω

+33uH)

Audio Precision



| Sweep | Trace | Color | Line Style | Thick | Data | Axis | Comment |
|-------|-------|-------|------------|-------|-------------------|-------|---------|
| 1 | 1 | Cyan | Solid | 1 | FFT.ChA Amplitude | Left | |
| 1 | 2 | Green | Solid | 1 | FFT.ChB Amplitude | Right | |

Figure17 GSM Power Supply Rejection vs Time

Audio Precision

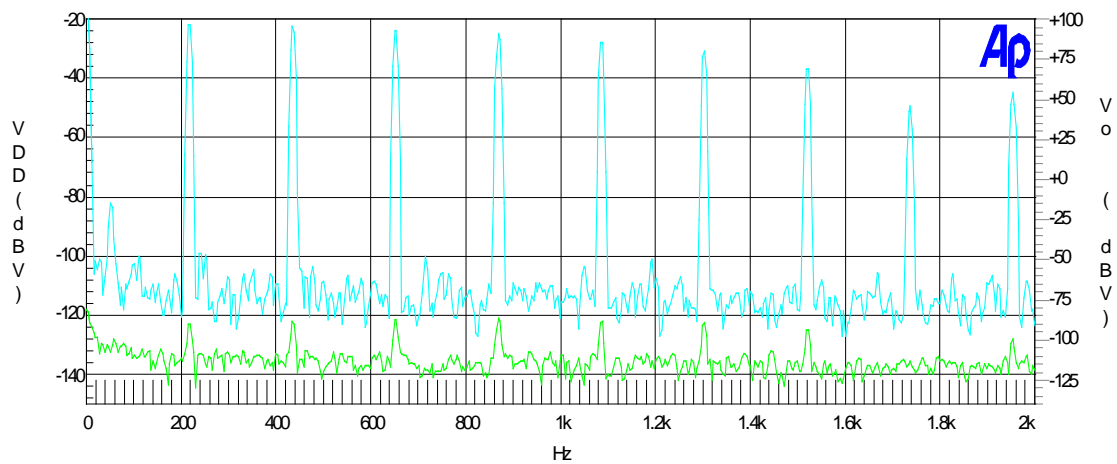

| Sweep | Trace | Color | Line Style | Thick | Data | Axis | Comment |
|-------|-------|-------|------------|-------|-------------------|-------|---------|
| 1 | 1 | Cyan | Solid | 1 | FFT.ChA Amplitude | Left | |
| 1 | 2 | Green | Solid | 1 | FFT.ChB Amplitude | Right | |

Figure18 GSM Power Supply Rejection vs Frequency

Package Dimensions

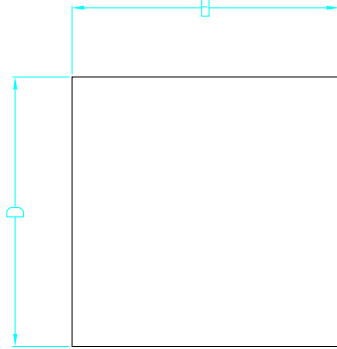

TOP VIEW

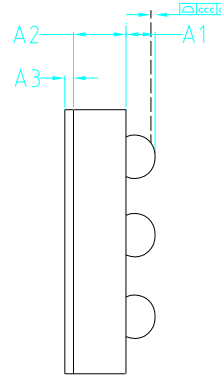

9 Bump WLCSP Dimensions (mm)

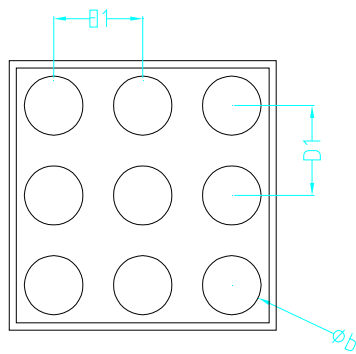

BOTTOM VIEW

| REF | MIN | TYP | MAX |
|-----|-------|-------|-------|
| A1 | 0.215 | 0.235 | 0.255 |
| A2 | 0.355 | 0.380 | 0.405 |
| A3 | 0.020 | 0.035 | 0.050 |
| D | 1.485 | 1.500 | 1.515 |
| D1 | | 0.500 | |
| E | 1.485 | 1.500 | 1.515 |
| E1 | | 0.500 | |
| b | 0.300 | 0.320 | 0.340 |