

OVERVIEW

The SM8610CV is a portable CD player laser driver IC. It uses a laser switching drive that reduces the laser power dissipation, thereby reducing data read current consumption and extending battery life significantly, when compared with existing devices which use a constant-current laser control method with corresponding high dissipation which places limits on battery life.

FEATURES

- 2.4V supply voltage
- Laser switching driver built-in
- Laser switching frequency range: 8.6 to 26MHz
- Switching pulsewidth duty adjustable
- Laser drive maximum current adjustable
- Laser control loop gain adjustable
- Power-save mode (Laser driver current stop function)
- Package: 16-pin VSOP

APPLICATIONS

- Portable CD player

ORDERING INFORMATION

Device	Package
SM8610CV	16-pin VSOP

PINOUT

(Top view)

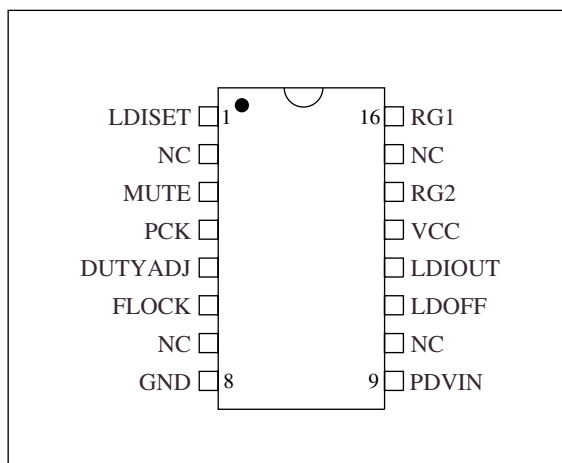

PACKAGE DIMENSIONS

(Unit: mm)

Weight: 0.07g

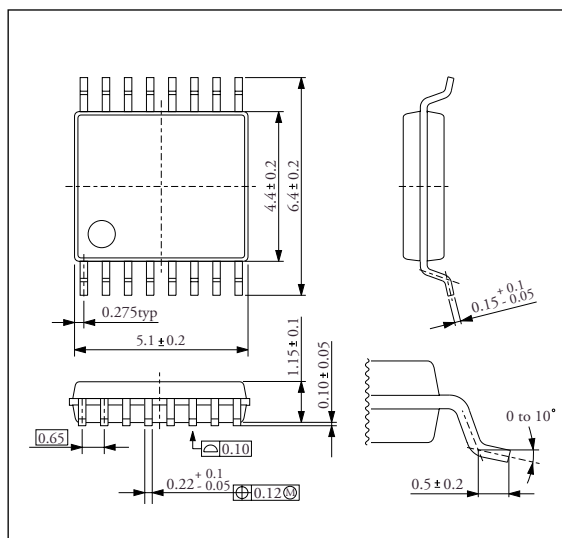

BLOCK DIAGRAM

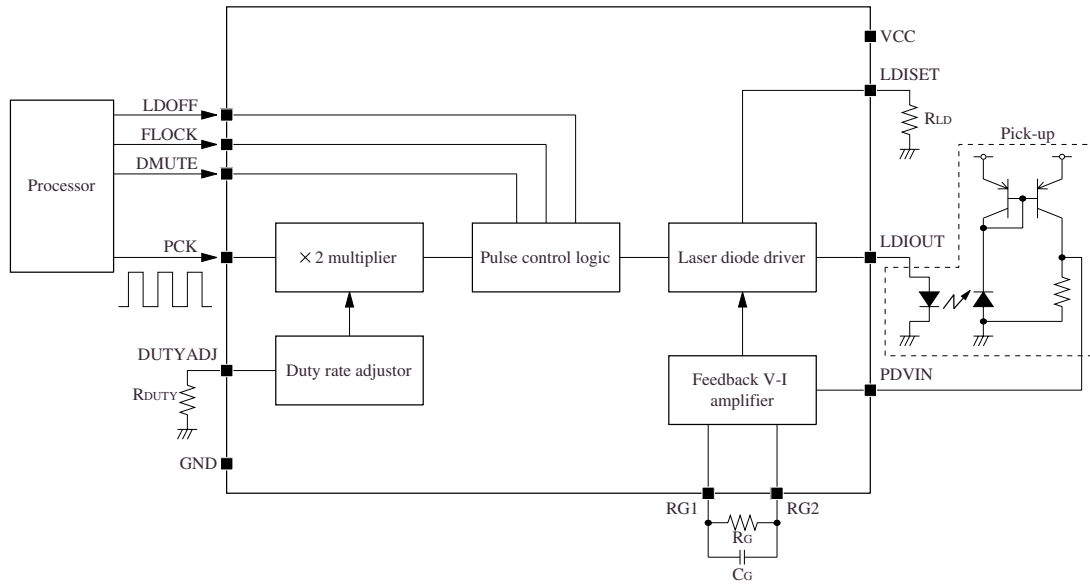

PIN DESCRIPTION

Number	Name	i/o	Description						
1	LDISET	o	Laser drive maximum current setting resistor connection						
2	NC	–	No connection (must be open)						
3	MUTE	ip	Muting signal <table border="1"> <thead> <tr> <th>DMUTE</th> <th>Laser drive state</th> </tr> </thead> <tbody> <tr> <td>L</td> <td>Laser switching drive</td> </tr> <tr> <td>H</td> <td>Laser constant-current drive</td> </tr> </tbody> </table>	DMUTE	Laser drive state	L	Laser switching drive	H	Laser constant-current drive
DMUTE	Laser drive state								
L	Laser switching drive								
H	Laser constant-current drive								
4	PCK	i	Data extract clock input						
5	DUTYADJ	o	Laser switching pulse duty adjust						
6	FLOCK	ip	Focus servo lead-in signal <table border="1"> <thead> <tr> <th>FLOCK</th> <th>Laser drive state</th> </tr> </thead> <tbody> <tr> <td>L</td> <td>Laser constant-current drive</td> </tr> <tr> <td>H</td> <td>Laser switching drive</td> </tr> </tbody> </table>	FLOCK	Laser drive state	L	Laser constant-current drive	H	Laser switching drive
FLOCK	Laser drive state								
L	Laser constant-current drive								
H	Laser switching drive								
7	NC	–	No connection (must be open)						
8	GND	–	Ground connection						
9	PDVIN	i	Laser current monitor voltage input						
10	NC	–	No connection (must be open)						
11	LDOFF	ip	Laser drive current stop signal input <table border="1"> <thead> <tr> <th>LDOFF</th> <th>Laser drive state</th> </tr> </thead> <tbody> <tr> <td>L</td> <td>Laser drive OFF In this state, the SM8610CV is in power-save mode.</td> </tr> <tr> <td>H</td> <td>Laser drive ON</td> </tr> </tbody> </table>	LDOFF	Laser drive state	L	Laser drive OFF In this state, the SM8610CV is in power-save mode.	H	Laser drive ON
LDOFF	Laser drive state								
L	Laser drive OFF In this state, the SM8610CV is in power-save mode.								
H	Laser drive ON								
12	LDIOUT	o	Laser drive current output						
13	VCC	–	2.4V supply voltage						
14	RG2	o	Laser control loop gain setting resistor connection						
15	NC	–	No connection (must be open)						
16	RG1	o	Laser control loop gain setting resistor connection						

ip: Built-in pull-down resistor

SPECIFICATIONS

Absolute Maximum Ratings

Parameter	Symbol	Rating	Unit
Supply voltage	V_{CC}	- 0.5 to 7.0	V
Input voltage	V_{IN}	- 0.5 to $V_{CC} + 0.5$	V
Input current	I_{IN}	- 3.0 to + 3.0	mA
Operating temperature	T_{OPR}	- 20 to 70	°C
Storage temperature	T_{STG}	- 40 to 125	°C
Power dissipation	P_W	96	mW

DC Electrical Characteristics

$V_{CC} = 2.3V$, $T_a = + 25\text{ }^{\circ}C$ unless otherwise noted

Parameter	Symbol	Condition	Rating			Unit	Test level
			min	typ	max		
Guaranteed operating supply voltage	V_{CC}		2.3	2.5	-	V	I
Current consumption	I_{CC1}	$V_{CC} = 2.5V$, $PDVIN = 0V$, $R_{LDISSET} = 47k\Omega$, $R_G = 33k\Omega$, LDOFF = HIGH, Excluding LDIOUT current	-	4.9	6.2	mA	I
	I_{CC2}	LDOFF = LOW	-	-	30	μA	I

Input Specifications

$V_{CC} = 2.3V$, $T_a = + 25\text{ }^{\circ}C$ unless otherwise noted

Parameter	Symbol	Condition	Rating			Unit
			min	typ	max	
PCK HIGH-level voltage	$V_{IH PCK}$		$V_{CC} \times 0.7$	-	-	V
PCK LOW-level voltage	$V_{IL PCK}$		-	-	$V_{CC} \times 0.3$	V
PCK HIGH-level sink current	I_{HPCK}		-	-	20	μA
LDOFF HIGH-level voltage	$V_{IHLDOFF}$		$V_{CC} \times 0.7$	-	-	V
LDOFF LOW-level voltage	$V_{ILLDOFF}$		-	-	$V_{CC} \times 0.3$	V
LDOFF HIGH-level sink current	I_{HLDOFF}		-	-	20	μA
FLOCK HIGH-level voltage	$V_{IHFLOCK}$		$V_{CC} \times 0.7$	-	-	V
FLOCK LOW-level voltage	$V_{ILFLOCK}$		-	-	$V_{CC} \times 0.3$	V
FLOCK HIGH-level sink current	I_{HFLOCK}		-	-	20	μA
MUTE HIGH-level voltage	V_{IHMUTE}		$V_{CC} \times 0.7$	-	-	V
MUTE LOW-level voltage	$V_{ILDMUTE}$		-	-	$V_{CC} \times 0.3$	V
MUTE HIGH-level sink current	I_{HDMUTE}		-	-	20	μA

Electrical Characteristics

$V_{CC} = 2.3V$, $T_a = +25\text{ }^\circ\text{C}$ unless otherwise noted

Parameter	Symbol	Condition	Rating			Unit	Test level
			min	typ	max		
PCK minimum input frequency	f_{PCKMIN}		–	–	4.3	MHz	I
PCK maximum input frequency	f_{PCKMAX}		13	–	–	MHz	I
Laser switching frequency range	f_{LD}		8.6	–	26	MHz	I
LDOFF response time 1	t_{LDOFF1}	LDOFF HIGH \rightarrow LOW	–	12	15	μs	III
LDOFF response time 2	t_{LDOFF2}	LDOFF LOW \rightarrow HIGH	–	–	15	μs	III
FLOCK response time 1	t_{FLOCK1}	FLOCK HIGH \rightarrow LOW DMUTE = LOW	–	–	15	ns	III
FLOCK response time 2	t_{FLOCK2}	FLOCK LOW \rightarrow HIGH DMUTE = LOW	–	–	15	ns	III
DMUTE response time 1	t_{DMUTE1}	DMUTE HIGH \rightarrow LOW FLOCK = HIGH	–	–	15	ns	III
DMUTE response time 2	t_{DMUTE2}	DMUTE LOW \rightarrow HIGH FLOCK = HIGH	–	–	15	ns	III
LDIOUT maximum output current	I_{LDMAX}	$R_{LD} = 27k\Omega$, $R_G = 33k\Omega$, $V(PDVIN) = DC$, 0V fixed	40	–	–	mA	I
LDIOUT rise time	$t_{rLDIOUT}$		–	–	15	ns	III
LDIOUT fall time	$t_{fLDIOUT}$		–	–	15	ns	III
LDISET voltage	V_{LDISET}		–	$1/3V_{CC}$		V	I
PDVIN convergence voltage	V_{PDVIN}	$R_G = 33k\Omega$, $V_{CC} = 2.5V$	150	–	180	mV	I
PDVIN input impedance	Z_{PDVIN}		1	–	–	$M\Omega$	I
APC loop cutoff frequency	f_{APC}	$R_G = 3k\Omega$, $C_G = 1000pF$	–	53	–	kHz	I
Minimum duty ratio	Dutymin	PCK = 13MHz, $R_{DUTY} = 15k\Omega$	–	26	–	%	I
Maximum duty ratio	Dutymax	PCK = 4.3MHz, $R_{DUTY} = 3k\Omega$	–	69	–	%	III
Minimum LD pulsewidth	T_{LDON}		–	15	–	ns	III

Note 1) LDOFF has internal pull-down resistor.

Note 2) FLOCK has internal pull-down resistor.

Note 3) DMUTE has internal pull-down resistor.

Note 4) LDISET is in high-impedance state when LDOFF is HIGH.

Note 5) DUTYADJ is in high-impedance state when LDOFF is HIGH.

Test level description

Test level I	100% of devices tested at 25°C
Test level II	Samples tested only
Test level III	Specifications guaranteed according to design and evaluation tests.
Test level IV	Parameter typical values only guaranteed.

FUNCTIONAL DESCRIPTION

LD Driver Control

The laser diode is controlled by 3 logic-level input signals: LDOFF, FLOCK, and MUTE. When LDOFF is HIGH, the laser diode driver is ON, and the mode is controlled by FLOCK and MUTE. When LDOFF is LOW, the laser diode driver is OFF and the IC is in power-save mode (LDIOUT output current = 0mA).

The LD has a chopper drive input when FLOCK is HIGH and MUTE is LOW.

Table 1. Laser diode control signals

LDOFF	FLOCK	MUTE	Laser drive state
H	L	L	LDIOUT constant-current output
H	L	H	LDIOUT constant-current output
H	H	L	LDIOUT chopper current output
H	H	H	LDIOUT constant-current output
L	×	×	LDIOUT = 0mA (power-save mode)

Note) × : Don't care.

Pulsewidth Adjust and Frequency Multiplication Function

The SM8610CV internal waveform processor multiplies the PCK input signal frequency by 2, and the pulse-width of this signal can be adjusted to control the duty ratio.

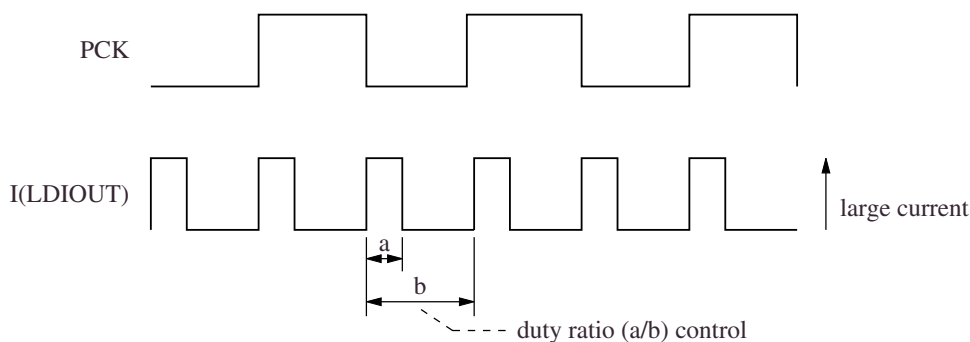

The output pulse current (LD chopper signal) on LDIOUT is automatically adjusted to maintain roughly constant duty ratio, even for changes in frequency. The LD chopper signal duty ratio can be adjusted by changing the resistance R_{DUTY} connected between the DUTYADJ and GND pins, as given by the following equation.

$$dutyratio = \left(1 - \frac{\frac{3}{2}V(DUTYADJ)}{\frac{1}{2}VCC(\approx V_{th})} \right) \times 100 = \frac{22[\text{k}\Omega] - 2 \times R_{DUTY}}{R_{DUTY} + 22[\text{k}\Omega]} \times 100 [\%]$$

$$V(DUTYADJ) = \frac{R_{DUTY}}{R_{DUTY} + 22[\text{k}\Omega]} \times VCC [\text{V}]$$

R_{DUTY} : DUTYADJ connected resistance [kΩ]

Laser Diode Drive Current Mid-value Set Function

The laser diode drive current mid-value can be adjusted by changing the resistance R_{LD} connected between the LDISET and GND pins. The laser diode drive current mid-value base value I_{LDSET} , given by the following equation, is set to the LDIOOUT output current when the PDVIN voltage is in balance state (147 to 193mV). Note that the actual LDIOOUT current may change due to feedback gain, and laser diode/photo diode variations.

$$I_{LDSET} = I_{LDSET} \times 1000 = \frac{800[V]}{R_{LD}} \text{ [A]}$$

R_{LD} : LDISET connected resistance [Ω]

APC Loop Gain Setting

The APC (Auto Power Control) loop gain can be adjusted by changing the external gain set resistance (R_G) connected between the RG1 and RG2 pins. The PDVIN voltage-to-laser drive current open-loop gain is given approximately by the following equation.

$$G_{mPDVIN} = 9.1 \times 10^{-5} R_G \text{ [S]}$$

Δ LDIOOUT current / Δ PDVIN voltage ratio [S]
 R_G : Resistance connected between RG1 and RG2 [Ω]

APC Loop Cutoff Frequency Setting

The APC loop cutoff frequency f_c is determined by the external resistance R_G and the capacitance C_G , connected between RG1 and RG2.

$$f_{c1} = \frac{1}{2\pi R_G C_G} \text{ [Hz]}$$

If C_G is connected between RG2 and VCC, the cutoff frequency is given as follows.

$$f_{c2} = \frac{1}{2\sqrt{2}\pi R_G C_G} \text{ [Hz]}$$

TYPICAL PERFORMANCE CHARACTERISTICS

Conditions: $V_{CC} = 2.4V$, $R_{LD} = 12k\Omega$, $R_{DUTY} = 2.5k\Omega$, $R_G = 2.5k\Omega$

APC loop cut-off frequency ($C_G = 0.01\mu F$)

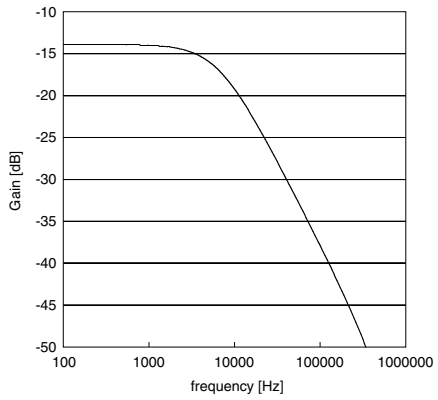

Output duty ratio

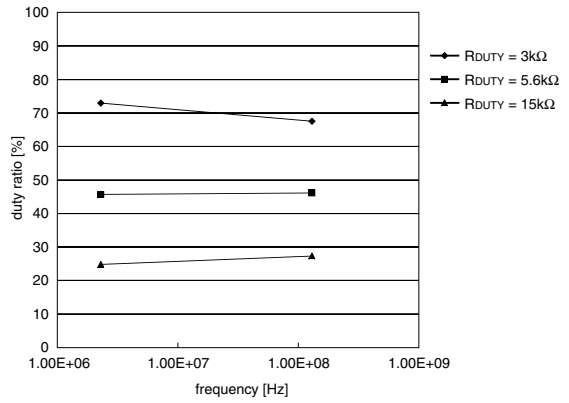

Open loop gain and LDIOOUT maximum output current ($R_{LDIOOUT} = 20\Omega$)

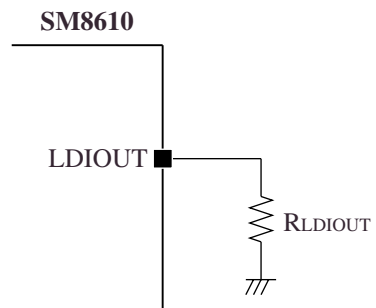
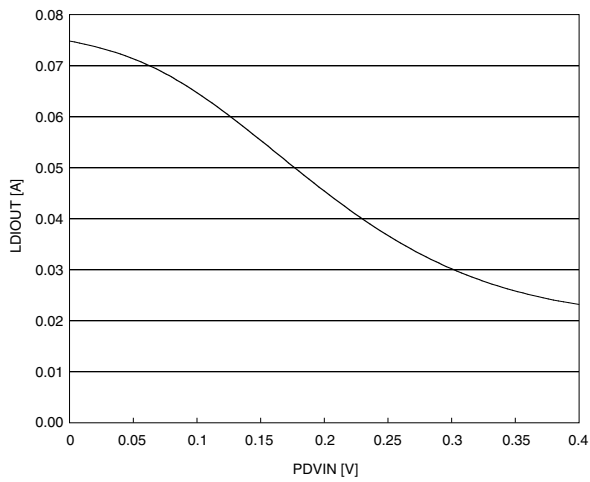

NIPPON PRECISION CIRCUITS INC. reserves the right to make changes to the products described in this data sheet in order to improve the design or performance and to supply the best possible products. Nippon Precision Circuits Inc. assumes no responsibility for the use of any circuits shown in this data sheet, conveys no license under any patent or other rights, and makes no claim that the circuits are free from patent infringement. Applications for any devices shown in this data sheet are for illustration only and Nippon Precision Circuits Inc. makes no claim or warranty that such applications will be suitable for the use specified without further testing or modification. The products described in this data sheet are not intended to use for the apparatus which influence human lives due to the failure or malfunction of the products. Customers are requested to comply with applicable laws and regulations in effect now and hereinafter, including compliance with export controls on the distribution or dissemination of the products. Customers shall not export, directly or indirectly, any products without first obtaining required licenses and approvals from appropriate government agencies.



NIPPON PRECISION CIRCUITS INC.

4-3, Fukuzumi 2-chome, Koto-ku,
Tokyo 135-8430, Japan
Telephone: +81-3-3642-6661
Facsimile: +81-3-3642-6698
<http://www.npc.co.jp/>
Email: sales@npc.co.jp

NC0102AE 2001.07