

# BCT0102

## 2-Bit Bidirectional Voltage-Level Translator

### GENERAL DESCRIPTION

This two-bit non-inverting translator is a bidirectional voltage-level translator and can be used to establish digital switching compatibility between mixed-voltage systems. It uses two separate configurable power-supply rails, with the A ports supporting operating voltages from 1.65V to 5.5V while it tracks the VCCA supply, and the B ports supporting operating voltages from 2.3V to 5.5V while it tracks the VCCB supply. This allows the support of both lower and higher logic signal levels while providing bidirectional translation capabilities between any of the 1.8V, 2.5V, 3.3V, and 5V voltage nodes.

When the output-enable (OE) input is low, all I/Os are placed in the high-impedance state, which significantly reduces the power-supply quiescent current consumption. OE has an internal pull-down current source, as long as VCCA is powered.

To ensure the high-impedance state during power up or power down, OE should be tied to GND through a pull-down resistor; the minimum value of the resistor is determined by the current-sourcing capability of the driver.

### FEATURES

- No Direction-Control Signal Needed
- Data Rates  
24Mbps (Push-Pull)  
2Mbps (Open-Drain)
- 1.65V to 5.5V on A Ports and 2.3V to 5.5V on B Ports ( $V_{CCA} \leq V_{CCB}$ )
- VCC Isolation: If Either VCC is at GND, Both Ports are in the High-Impedance State
- No Power-Supply Sequencing Required, Either VCCA or VCCB can be Ramped First
- I<sub>OFF</sub>: Supports Partial-Power-Down Mode Operation
- Available in TSOT23-8, XTDFN1.4X1.0-8L, QFN1.4X1.2-8L package.

### APPLICATIONS

- I2C BUS
- Portable POS Systems
- Smart Card Readers
- Cell-Phones
- GPS
- Portable Communication Devices

### ORDERING INFORMATION

| Order Number  | Package Type    | Temperature Range | Marking | QTY/Reel |
|---------------|-----------------|-------------------|---------|----------|
| BCT0102EDA-TR | TSOT23-8        | -40°C to +85°C    | SAXX    | 4000     |
| BCT0102ETA-TR | XTDFN1.4X1.0-8L | -40°C to +85°C    | SAXX    | 3000     |
| BCT0102EGA-TR | QFN1.4X1.2-8L   | -40°C to +85°C    | SAXX    | 3000     |

Note 1: "SA" in Marking is product short code for BCT0102.  
"XX" in Marking will be appeared as the batch code.

### PIN CONFIGURATION (Top View)

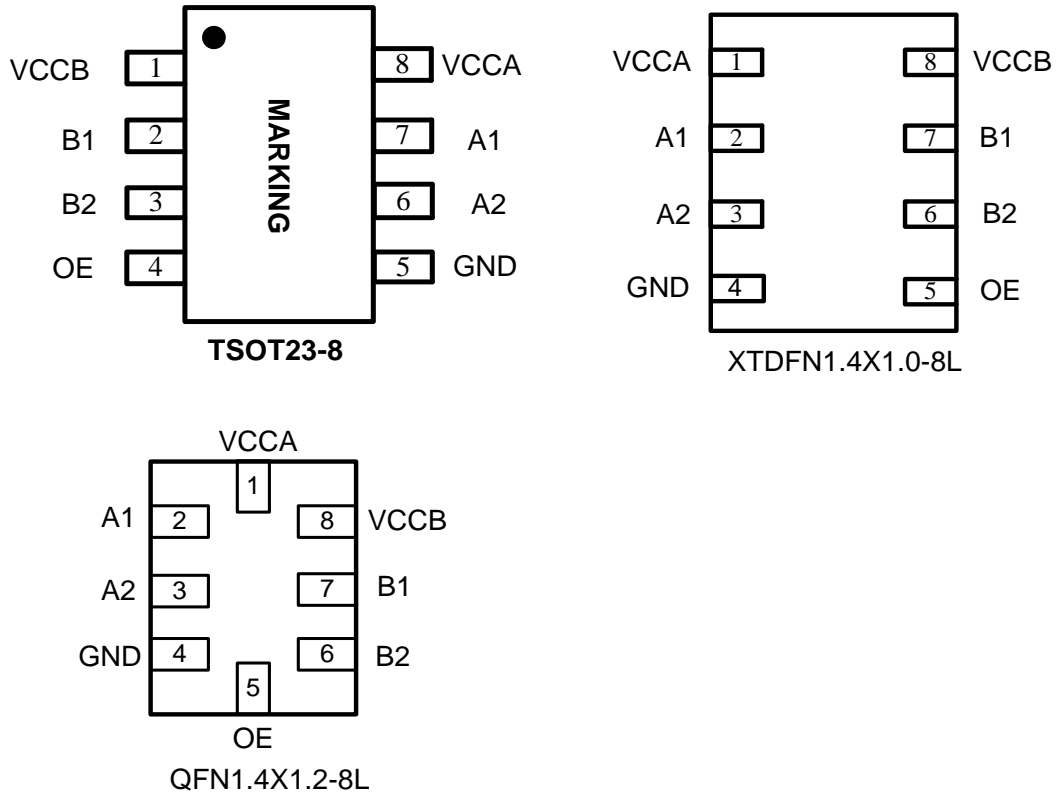

### PIN DESCRIPTION

| PIN |         | NAME             | FUNCTION  |
|-----|---------|------------------|---|
| SOT | DFN/QFN |                  |   |
| 1   | 8       | V <sub>CCB</sub> | B-Port Supply Voltage. $2.3V \leq V_{CCB} \leq 5.5V$ .  |
| 2   | 7       | B1               | Input/Output B. Referenced to V <sub>CCB</sub> .  |
| 3   | 6       | B2               | Input/Output B. Referenced to V <sub>CCB</sub> .  |
| 4   | 5       | OE               | Output Enable (Active High). Pull OE low to place all outputs in 3-state mode. Referenced to V <sub>CCA</sub> . |
| 5   | 4       | GND              | Ground.   |
| 6   | 3       | A2               | Input/Output A. Referenced to V <sub>CCA</sub> .  |
| 7   | 2       | A1               | Input/Output A. Referenced to V <sub>CCA</sub> .  |
| 8   | 1       | V <sub>CCA</sub> | A-Port Supply Voltage. $1.65V \leq V_{CCA} \leq 5.5V$ and $V_{CCA} \leq V_{CCB}$ .                              |



# BCT0102

## 2-Bit Bidirectional Voltage-Level Translator

### ABSOLUTE MAXIMUM RATINGS

|   |                           |
|---|---------------------------|
| $V_{CCA}$ , Supply Voltage Range.....   | -0.3V to 6V               |
| $V_{CCB}$ , Supply Voltage Range.....   | -0.3V to 6V               |
| $V_I$ , A Port, B Port, OE Input Voltage Range (2).....                                   | -0.3V to 6V               |
| $V_O$ , Voltage Range Applied to Any Output in the High- Impedance or Power-Off State (2) |                           |
| A Port.....   | -0.3V to 6V               |
| B Port.....   | -0.3V to 6V               |
| $V_O$ , Voltage Range Applied to Any Output in the High or Low State (2) (3)              |                           |
| A Port.....   | -0.3V to $V_{CCA} + 0.3V$ |
| B Port.....   | -0.3V to $V_{CCB} + 0.3V$ |
| $I_{IK}$ , Input Clamp Current ( $V_I < 0$ ) .....  | -50mA                     |
| $I_{OK}$ , Output Clamp Current ( $V_O < 0$ ) .....                                       | -50mA                     |
| $I_O$ , Continuous Output Current.....  | $\pm 50mA$                |
| Continuous Current through $V_{CCA}$ , $V_{CCB}$ , or GND.....                            | $\pm 100mA$               |
| Operating Temperature Range.....  | -40°C to +85°C            |
| Junction Temperature.....   | 150°C                     |
| Storage Temperature Range.....  | -65°C to +150°C           |
| Lead Temperature (Soldering, 10sec).....  | 260°C                     |
| ESD   |                           |
| HBM B Port.....   | 8KV                       |
| HBM Other Pin.....  | 4KV                       |

NOTE:

1. Stresses beyond those listed under "Absolute Maximum Ratings" may cause permanent damage to the device. These are stress ratings only, and functional operation of the device at these or any other conditions beyond those indicated in the operational sections of the specifications is not implied. Exposure to absolute Maximum rating conditions for extended periods may affect device reliability.
2. The input and output negative-voltage ratings may be exceeded if the input and output current ratings are observed.
3. The value of  $V_{CCA}$  and  $V_{CCB}$  are provided in the recommended operating conditions table.



# BCT0102

## 2-Bit Bidirectional Voltage-Level Translator

### ELECTRICAL CHARACTERISTICS

( $V_{CCA} = 1.65V$  to  $5.5V$ ,  $V_{CCB} = 2.3V$  to  $5.5V$ , typical values are at  $T_A = +25^\circ C$ , unless otherwise noted)

| PARAMETER  |  | CONDITIONS  | MIN                  | TYP | MAX                   | UNITS   |
|--|--|---|----------------------|-----|-----------------------|---------|
| <b>RECOMMENDED OPERATING CONDITIONS</b> <sup>(1) (2)</sup> |  |   |                      |     |                       |         |
| Supply Voltage <sup>(3)</sup>                              | $V_{CCA}$  |   | 1.65                 |     | 5.5                   | V       |
|  | $V_{CCB}$  |   | 2.3                  |     | 5.5                   |         |
| High-Level Input Voltage<br>( $V_{IH}$ )                   | A Port I/Os  | $V_{CCA} = 1.65V$ to $1.95V$ , $V_{CCB} = 2.3V$ to $5.5V$   | $V_{CCI} - 0.2$      |     | $V_{CCI}$             | V       |
|  |  | $V_{CCA} = 2.3V$ to $5.5V$ , $V_{CCB} = 2.3V$ to $5.5V$     | $V_{CCI} - 0.4$      |     | $V_{CCI}$             |         |
|  | B Port I/Os  |   | $V_{CCI} - 0.4$      |     | $V_{CCI}$             |         |
|  | OE Input   |   | $V_{CCA} \times 0.8$ |     | 5.5                   |         |
| Low-Level Input Voltage<br>( $V_{IL}$ )                    | A Port I/Os  |   | 0                    |     | 0.15                  | V       |
|  | B Port I/Os  |   | 0                    |     | 0.15                  |         |
|  | OE Input   |   | 0                    |     | $V_{CCA} \times 0.25$ |         |
| Input Transition Rise or Fall Rate ( $\Delta t/\Delta V$ ) | A Port I/Os Push-Pull Driving                      |   |                      |     | 10                    | ns/V    |
|  | B Port I/Os Push-Pull Driving                      |   |                      |     | 10                    |         |
|  | Control Input                                      |   |                      |     | 10                    |         |
| <b>ELECTRICAL CHARACTERISTICS</b>                          |  |   |                      |     |                       |         |
| A Port High Level Output Voltage ( $V_{OHA}$ )             | $I_{OH} = -20\mu A$ , $V_{IB} \geq V_{CCB} - 0.4V$ |   | $V_{CCA} \times 0.7$ |     |                       | V       |
| A Port Low Level Output Voltage ( $V_{OLA}$ )              | $I_{OL} = 1mA$ , $V_{IB} \leq 0.15V$               |   |                      |     | 0.4                   |         |
| B Port High Level Output Voltage ( $V_{OHB}$ )             | $I_{OH} = -20\mu A$ , $V_{IA} \geq V_{CCA} - 0.4V$ |   | $V_{CCB} \times 0.7$ |     |                       |         |
| B Port Low Level Output Voltage ( $V_{OLB}$ )              | $I_{OL} = 1mA$ , $V_{IA} \leq 0.15V$               |   |                      |     | 0.4                   |         |
| Input Leakage Current ( $I_I$ )                            | OE   |   |                      | 0.5 |                       | $\mu A$ |
| Power Off Leakage<br>Current ( $I_{OFF}$ )                 | A Port   | $V_{CCA} = 0V$ , $V_{CCB} = 0V$ to $5.5V$                   |                      | 0.1 |                       |         |
|  | B Port   | $V_{CCA} = 0V$ to $5.5V$ , $V_{CCB} = 0V$                   |                      | 0.1 |                       |         |
| 3-State Output Leakage ( $I_{OZ}$ )                        | A or B Port  | OE = 0V   |                      | 0.1 |                       |         |
| Quiescent Supply Current ( $I_{CCA}$ )                     | $V_I = V_O = OPEN$ ,<br>$I_O = 0$                  | $V_{CCA} = 1.65V$ to $V_{CCB}$ , $V_{CCB} = 2.3V$ to $5.5V$ |                      | 0.1 |                       | $\mu A$ |
|  |  | $V_{CCA} = 5.5V$ , $V_{CCB} = 0V$                           |                      | 0.1 |                       |         |
|  |  | $V_{CCA} = 0V$ , $V_{CCB} = 5.5V$                           |                      | 0.1 |                       |         |
| Quiescent Supply Current ( $I_{CCB}$ )                     | $V_I = V_O = OPEN$ ,<br>$I_O = 0$                  | $V_{CCA} = 1.65V$ to $V_{CCB}$ , $V_{CCB} = 2.3V$ to $5.5V$ |                      | 7   |                       | $\mu A$ |
|  |  | $V_{CCA} = 5.5V$ , $V_{CCB} = 0V$                           |                      | 0.1 |                       |         |
|  |  | $V_{CCA} = 0V$ , $V_{CCB} = 5.5V$                           |                      | 0.1 |                       |         |
| Quiescent Supply Current ( $I_{CCA} + I_{CCB}$ )           | $V_I = V_O = OPEN$ ,<br>$I_O = 0$                  | $V_{CCA} = 1.65V$ to $V_{CCB}$ , $V_{CCB} = 2.3V$ to $5.5V$ |                      | 7.1 |                       | $\mu A$ |



# BCT0102

## 2-Bit Bidirectional Voltage-Level Translator

### ELECTRICAL CHARACTERISTICS

( $V_{CCA} = 1.65V$  to  $5.5V$ ,  $V_{CCB} = 2.3V$  to  $5.5V$ , typical values are at  $T_A = +25^\circ C$ , unless otherwise noted)

| PARAMETER                                    | CONDITIONS                                | MIN  | TYP | MAX | UNITS |         |
|--|---|--|-----|-----|-------|---------|
| Quiescent Supply Current ( $I_{CCZA}$ )      | $V_I = V_{CCI}$ , $I_O = 0$ ,<br>OE = GND | $V_{CCA} = 1.65V$ to $V_{CCB}$ ,<br>$V_{CCB} = 2.3V$ to $5.5V$ |     | 0.1 |       | $\mu A$ |
|  |   | $V_{CCA} = 5.5V$ , $V_{CCB} = 0V$                              |     | 0.1 |       |         |
|  |   | $V_{CCA} = 0V$ , $V_{CCB} = 5.5V$                              |     | 0.1 |       |         |
| Quiescent Supply Current ( $I_{CCZB}$ )      | $V_I = V_{CCI}$ , $I_O = 0$ ,<br>OE = GND | $V_{CCA} = 1.65V$ to $V_{CCB}$ ,<br>$V_{CCB} = 2.3V$ to $5.5V$ |     | 0.1 |       | $\mu A$ |
|  |   | $V_{CCA} = 5.5V$ , $V_{CCB} = 0V$                              |     | 0.1 |       |         |
|  |   | $V_{CCA} = 0V$ , $V_{CCB} = 5.5V$                              |     | 0.1 |       |         |
| OE Input Capacitance ( $C_I$ )               | $V_{CCA} = 3.3V$ , $V_{CCB} = 3.3V$       |  | 3.6 |     | pF    |         |
| Input/Output Capacitance A Port ( $C_{IO}$ ) | $V_{CCA} = 3.3V$ , $V_{CCB} = 3.3V$       |  | 5.4 |     | pF    |         |
| Input/Output Capacitance B Port ( $C_{IO}$ ) |   |  | 6.3 |     |       |         |

**NOTES:**

1.  $V_{CCI}$  is the  $V_{CC}$  associated with the input port.
2.  $V_{CCO}$  is the  $V_{CC}$  associated with the output port.
3.  $V_{CCA}$  must be less than or equal to  $V_{CCB}$ , and  $V_{CCA}$  must not exceed  $5.5V$ .



# BCT0102

## 2-Bit Bidirectional Voltage-Level Translator

### TIMING REQUIREMENTS

(typical values are at  $T_A = +25^\circ\text{C}$ , unless otherwise noted)

|  |                    | $V_{CCB} = 2.5\text{V}$ | $V_{CCB} = 3.3\text{V}$ | $V_{CCB} = 5\text{V}$ | UNITS |      |
|--|--------------------|-------------------------|-------------------------|-----------------------|-------|------|
|  |                    | TYP                     | TYP                     | TYP                   |       |      |
| <b>(<math>T_A = +25^\circ\text{C}</math>, <math>V_{CCA} = 1.8\text{V}</math>, unless otherwise noted.)</b> |                    |                         |                         |                       |       |      |
| Data Rate  | Push-Pull Driving  |                         | 21                      | 22                    | 24    | Mbps |
|  | Open-Drain Driving |                         | 2                       | 2                     | 2     |      |
| Pulse Duration ( $t_w$ )   | Push-Pull Driving  | Data Inputs             | 47                      | 45                    | 41    | ns   |
|  | Open-Drain Driving |                         | 500                     | 500                   | 500   |      |
| <b>(<math>T_A = +25^\circ\text{C}</math>, <math>V_{CCA} = 2.5\text{V}</math>, unless otherwise noted.)</b> |                    |                         |                         |                       |       |      |
| Data Rate  | Push-Pull Driving  |                         | 20                      | 22                    | 24    | Mbps |
|  | Open-Drain Driving |                         | 2                       | 2                     | 2     |      |
| Pulse Duration ( $t_w$ )   | Push-Pull Driving  | Data Inputs             | 50                      | 45                    | 41    | ns   |
|  | Open-Drain Driving |                         | 500                     | 500                   | 500   |      |
| <b>(<math>T_A = +25^\circ\text{C}</math>, <math>V_{CCA} = 3.3\text{V}</math>, unless otherwise noted.)</b> |                    |                         |                         |                       |       |      |
| Data Rate  | Push-Pull Driving  |                         |                         | 23                    | 24    | Mbps |
|  | Open-Drain Driving |                         |                         | 2                     | 2     |      |
| Pulse Duration ( $t_w$ )   | Push-Pull Driving  | Data Inputs             |                         | 43                    | 41    | ns   |
|  | Open-Drain Driving |                         |                         | 500                   | 500   |      |
| <b>(<math>T_A = +25^\circ\text{C}</math>, <math>V_{CCA} = 5\text{V}</math>, unless otherwise noted.)</b>   |                    |                         |                         |                       |       |      |
| Data Rate  | Push-Pull Driving  |                         |                         |                       | 24    | Mbps |
|  | Open-Drain Driving |                         |                         |                       | 2     |      |
| Pulse Duration ( $t_w$ )   | Push-Pull Driving  | Data Inputs             |                         |                       | 41    | ns   |
|  | Open-Drain Driving |                         |                         |                       | 500   |      |

### SWITCHING CHARACTERISTICS

( $V_{CCA} = 1.8V$ , typical values are at  $T_A = +25^\circ C$ , unless otherwise noted)

| PARAMETER                      | FROM (INPUT)            | TO (OUTPUT) | TEST CONDITIONS    | $V_{CCB} = 2.5V$ | $V_{CCB} = 3.3V$ | $V_{CCB} = 5V$ | UNITS |
|--------------------------------|-------------------------|-------------|--------------------|------------------|------------------|----------------|-------|
| $t_{PHL}$                      | A                       | B           | Push-Pull Driving  | 2.4              | 3.0              | 4.3            | ns    |
|                                |                         |             | Open-Drain Driving | 26.0             | 26.3             | 26.7           |       |
| $t_{PLH}$                      |                         |             | Push-Pull Driving  | 4.0              | 3.6              | 3.5            |       |
|                                |                         |             | Open-Drain Driving | 175              | 145              | 110            |       |
| $t_{PHL}$                      | B                       | A           | Push-Pull Driving  | 2.0              | 1.9              | 2.1            | ns    |
|                                |                         |             | Open-Drain Driving | 26.0             | 26.1             | 26.2           |       |
| $t_{PLH}$                      |                         |             | Push-Pull Driving  | 1.7              | 1.5              | 1.4            |       |
|                                |                         |             | Open-Drain Driving | 133              | 69               | 51             |       |
| $t_{EN} (t_{PZH} \& t_{PZL})$  | OE                      | A or B      |                    | 17               | 15               | 14             | ns    |
| $t_{DIS} (t_{PHZ} \& t_{PLZ})$ | OE                      | A or B      |                    | 614              | 616              | 626            |       |
| $t_{rA}$                       | A Port Rise Time        |             | Push-Pull Driving  | 6.6              | 5.8              | 5.4            | ns    |
|                                |                         |             | Open-Drain Driving | 89               | 31               | 10             |       |
| $t_{rB}$                       | B Port Rise Time        |             | Push-Pull Driving  | 5.6              | 4.6              | 3.9            | ns    |
|                                |                         |             | Open-Drain Driving | 128              | 98               | 58             |       |
| $t_{fA}$                       | A Port Fall Time        |             | Push-Pull Driving  | 2.9              | 2.7              | 2.6            | ns    |
|                                |                         |             | Open-Drain Driving | 1.9              | 1.7              | 1.6            |       |
| $t_{fB}$                       | B Port Fall Time        |             | Push-Pull Driving  | 4.6              | 5.9              | 8.0            | ns    |
|                                |                         |             | Open-Drain Driving | 2.2              | 2.3              | 2.9            |       |
| $t_{sk(0)}$                    | Channel-to-Channel Skew |             |                    | 0.5              | 0.5              | 0.5            | ns    |
| Data Rate                      |                         |             | Push-Pull Driving  | 21               | 22               | 24             | Mbps  |
|                                |                         |             | Open-Drain Driving | 2                | 2                | 2              |       |

### SWITCHING CHARACTERISTICS

( $V_{CCA} = 2.5V$ , typical values are at  $T_A = +25^\circ C$ , unless otherwise noted)

| PARAMETER                      | FROM (INPUT)            | TO (OUTPUT) | TEST CONDITIONS    | $V_{CCB} = 2.5V$ | $V_{CCB} = 3.3V$ | $V_{CCB} = 5V$ | UNITS |
|--------------------------------|-------------------------|-------------|--------------------|------------------|------------------|----------------|-------|
| $t_{PHL}$                      | A                       | B           | Push-Pull Driving  | 2.7              | 3.3              | 4.8            | ns    |
|                                |                         |             | Open-Drain Driving | 26.2             | 26.4             | 26.7           |       |
| $t_{PLH}$                      |                         |             | Push-Pull Driving  | 2.6              | 2.4              | 2.3            |       |
|                                |                         |             | Open-Drain Driving | 169              | 144              | 110            |       |
| $t_{PHL}$                      | B                       | A           | Push-Pull Driving  | 2.4              | 2.3              | 2.4            | ns    |
|                                |                         |             | Open-Drain Driving | 26.3             | 26.4             | 26.5           |       |
| $t_{PLH}$                      |                         |             | Push-Pull Driving  | 2.0              | 1.9              | 1.8            |       |
|                                |                         |             | Open-Drain Driving | 165              | 118              | 55             |       |
| $t_{EN} (t_{PZH} \& t_{PZL})$  | OE                      | A or B      |                    | 14               | 13               | 12             | ns    |
| $t_{DIS} (t_{PHZ} \& t_{PLZ})$ | OE                      | A or B      |                    | 630              | 635              | 640            |       |
| $t_{rA}$                       | A Port Rise Time        |             | Push-Pull Driving  | 3.2              | 2.8              | 2.6            | ns    |
|                                |                         |             | Open-Drain Driving | 120              | 70               | 10             |       |
| $t_{rB}$                       | B Port Rise Time        |             | Push-Pull Driving  | 4.5              | 3.4              | 2.6            | ns    |
|                                |                         |             | Open-Drain Driving | 122              | 96               | 62             |       |
| $t_{fA}$                       | A Port Fall Time        |             | Push-Pull Driving  | 4.9              | 5.0              | 4.8            | ns    |
|                                |                         |             | Open-Drain Driving | 2.0              | 1.9              | 1.7            |       |
| $t_{fB}$                       | B Port Fall Time        |             | Push-Pull Driving  | 4.8              | 6.1              | 8.3            | ns    |
|                                |                         |             | Open-Drain Driving | 1.9              | 2.1              | 2.7            |       |
| $t_{sk(0)}$                    | Channel-to-Channel Skew |             |                    | 0.5              | 0.5              | 0.5            | ns    |
| Data Rate                      |                         |             | Push-Pull Driving  | 20               | 22               | 24             | Mbps  |
|                                |                         |             | Open-Drain Driving | 2                | 2                | 2              |       |



### SWITCHING CHARACTERISTICS

( $V_{CCA} = 3.3V$ , typical values are at  $T_A = +25^\circ C$ , unless otherwise noted)

| PARAMETER                           | FROM (INPUT)            | TO (OUTPUT) | TEST CONDITIONS    | $V_{CCB} = 3.3V$ | $V_{CCB} = 5V$ | UNITS |
|-------------------------------------|-------------------------|-------------|--------------------|------------------|----------------|-------|
| $t_{PHL}$                           | A                       | B           | Push-Pull Driving  | 3.5              | 4.9            | ns    |
|                                     |                         |             | Open-Drain Driving | 26.3             | 26.7           |       |
| $t_{PLH}$                           |                         |             | Push-Pull Driving  | 2.2              | 2.0            |       |
|                                     |                         |             | Open-Drain Driving | 133              | 104            |       |
| $t_{PHL}$                           | B                       | A           | Push-Pull Driving  | 3.0              | 3.2            | ns    |
|                                     |                         |             | Open-Drain Driving | 26.6             | 26.8           |       |
| $t_{PLH}$                           |                         |             | Push-Pull Driving  | 1.8              | 1.7            |       |
|                                     |                         |             | Open-Drain Driving | 132              | 83             |       |
| $t_{EN}$ ( $t_{PZH}$ & $t_{PZL}$ )  | OE                      | A or B      |                    | 12               | 11             | ns    |
| $t_{DIS}$ ( $t_{PHZ}$ & $t_{PLZ}$ ) | OE                      | A or B      |                    | 630              | 635            |       |
| $t_{rA}$                            | A Port Rise Time        |             | Push-Pull Driving  | 2.2              | 2.0            | ns    |
|                                     |                         |             | Open-Drain Driving | 87               | 36             |       |
| $t_{rB}$                            | B Port Rise Time        |             | Push-Pull Driving  | 2.9              | 2.3            | ns    |
|                                     |                         |             | Open-Drain Driving | 87               | 56             |       |
| $t_{fA}$                            | A Port Fall Time        |             | Push-Pull Driving  | 6.2              | 5.8            | ns    |
|                                     |                         |             | Open-Drain Driving | 2.3              | 2.0            |       |
| $t_{fB}$                            | B Port Fall Time        |             | Push-Pull Driving  | 6.5              | 8.2            | ns    |
|                                     |                         |             | Open-Drain Driving | 2.0              | 2.5            |       |
| $t_{sk(0)}$                         | Channel-to-Channel Skew |             |                    | 0.5              | 0.5            | ns    |
| Data Rate                           |                         |             | Push-Pull Driving  | 23               | 24             | Mbps  |
|                                     |                         |             | Open-Drain Driving | 2                | 2              |       |

### SWITCHING CHARACTERISTICS

( $V_{CCA} = 5.0V$ , typical values are at  $T_A = +25^\circ C$ , unless otherwise noted)

| PARAMETER                      | FROM (INPUT)            | TO (OUTPUT) | TEST CONDITIONS    | $V_{CCB} = 5V$ | UNITS |
|--------------------------------|-------------------------|-------------|--------------------|----------------|-------|
| $t_{PHL}$                      | A                       | B           | Push-Pull Driving  | 5.4            | ns    |
|                                |                         |             | Open-Drain Driving | 26.7           |       |
| $t_{PLH}$                      |                         |             | Push-Pull Driving  | 1.9            |       |
| Open-Drain Driving             |                         |             | 120                |                |       |
| $t_{PHL}$                      | B                       | A           | Push-Pull Driving  | 5.6            | ns    |
|                                |                         |             | Open-Drain Driving | 27.3           |       |
| $t_{PLH}$                      |                         |             | Push-Pull Driving  | 1.7            |       |
|                                |                         |             | Open-Drain Driving | 126            |       |
| $t_{EN} (t_{PZH} \& t_{PZL})$  | OE                      | A or B      |                    | 10             | ns    |
| $t_{DIS} (t_{PHZ} \& t_{PLZ})$ | OE                      | A or B      |                    | 636            | ns    |
| $t_{rA}$                       | A Port Rise Time        |             | Push-Pull Driving  | 1.8            | ns    |
|                                |                         |             | Open-Drain Driving | 79             |       |
| $t_{rB}$                       | B Port Rise Time        |             | Push-Pull Driving  | 2.2            | ns    |
|                                |                         |             | Open-Drain Driving | 73             |       |
| $t_{fA}$                       | A Port Fall Time        |             | Push-Pull Driving  | 8.7            | ns    |
|                                |                         |             | Open-Drain Driving | 2.7            |       |
| $t_{fB}$                       | B Port Fall Time        |             | Push-Pull Driving  | 8.6            | ns    |
|                                |                         |             | Open-Drain Driving | 2.4            |       |
| $t_{sk(0)}$                    | Channel-to-Channel Skew |             |                    | 0.5            | ns    |
| Data Rate                      |                         |             | Push-Pull Driving  | 24             | Mbps  |
|                                |                         |             | Open-Drain Driving | 2              |       |

### APPLICATION INFORMATION

The BCT0102 can be used to bridge the digital-switching compatibility gap between two voltage nodes to successfully interface logic threshold levels found in electronic systems. It should be used in a point-to-point topology for interfacing devices or systems operating at different interface voltages with one another. Its primary target application use is for interfacing with open-drain drivers on the data I/Os such as I2C or 1-wire, where the data is bidirectional and no control signal is available. The BCT0102 can also be used in applications where a push-pull driver is connected to the data I/Os

### Block Diagram

The BCT0102 architecture (see Figure 1) is an auto-direction-sensing based translator that does not require a direction-control signal to control the direction of data flow from A to B or from B to A.

These two bidirectional channels independently determine the direction of data flow without a direction-control signal. Each I/O pin can be automatically reconfigured as either an input or an output, which is how this auto-direction feature is realized.

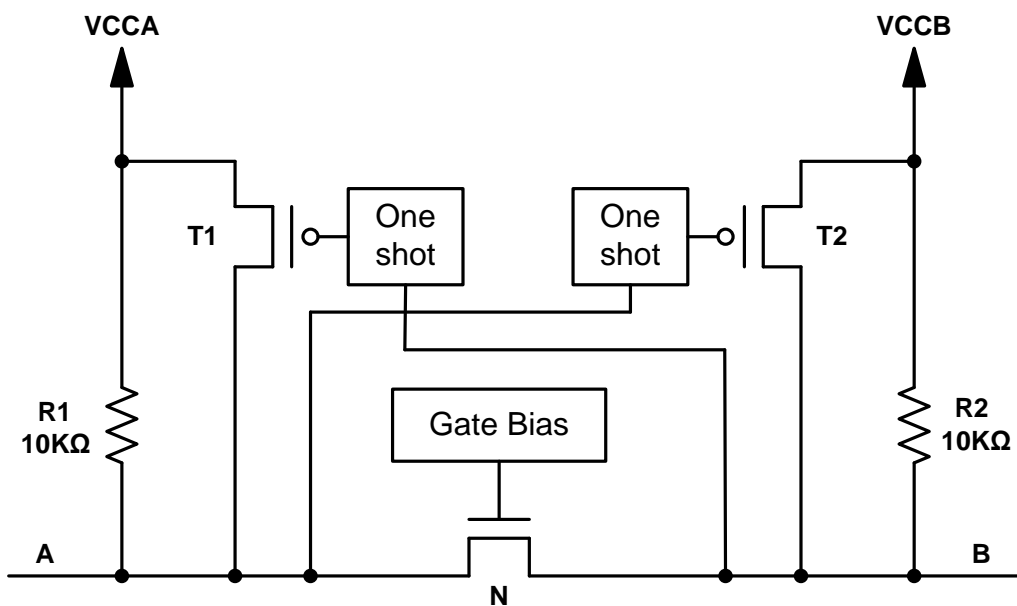

Figure 1 Block Diagram of BCT0102 I/O Cell



# BCT0102

## 2-Bit Bidirectional Voltage-Level Translator

---

The BCT0102 employs two key circuits to enable this voltage translation: An N-channel pass-gate transistor topology that ties the A port to the B port. Output one-shot (O.S.) edge-rate accelerator circuitry to detect and accelerate rising edges on the A or B ports.

### Input Driver Requirements

The fall time ( $t_{fA}$ ,  $t_{fB}$ ) of a signal depends on the output impedance of the external device driving the data I/Os of the BCT0102. Similarly, the  $t_{PHL}$  and data rates also depend on the output impedance of the external driver. The values for  $t_{fA}$ ,  $t_{fB}$ ,  $t_{PHL}$ , and data rates in the datasheet assume that the output impedance of the external driver is less than 50Ω.

### Power Up

During operation, ensure that  $V_{CCA} \leq V_{CCB}$  at all times. The sequencing of each power supply will not damage the device during the power up operation, so either power supply can be ramped up first.

### Output Load Considerations

We recommend careful PCB layout practices with short PCB trace lengths to avoid excessive capacitive loading and to ensure that proper O.S. triggering takes place. PCB signal trace-lengths should be kept short enough such that the round trip delay of any reflection is less than the one-shot duration. This improves signal integrity by ensuring that any reflection sees a low impedance at the driver. The O.S. circuits have been designed to stay on for approximately 30ns. The maximum capacitance of the lumped load that can be driven also depends directly on the one-shot duration. With very heavy capacitive loads, the one-shot can time-out before the signal is driven fully to the positive rail. The O.S. duration has been set to best optimize trade-offs between dynamic  $I_{CC}$ , load driving capability, and maximum bit-rate considerations. Both PCB trace length and connectors add to the capacitance that the BCT0102 output sees, so it is recommended that this lumped-load capacitance be considered to avoid O.S. retriggering, bus contention, output signal oscillations, or other adverse system-level affects.

### Enable and Disable

The BCT0102 has an OE input that is used to disable the device by setting OE low, which places all I/Os in the Hi-Z state. OE has an internal pull-down current source, as long as  $V_{CCA}$  is powered. The disable time ( $t_{DIS}$ ) indicates the delay between the time when OE goes low and when the outputs are disabled (Hi-Z). The enable time ( $t_{EN}$ ) indicates the amount of time the user must allow for the one-shot circuitry to become operational after OE is taken high.

### Pull-up or Pull-down Resistors on I/O Lines

Each A port I/O has an internal 10k $\Omega$  pull-up resistor to  $V_{CCA}$ , and each B port I/O has an internal 10k $\Omega$  pull-up resistor to  $V_{CCB}$ . If a smaller value of pull-up resistor is required, an external resistor must be added from the I/O to  $V_{CCA}$  or  $V_{CCB}$  (in parallel with the internal 10k $\Omega$  resistors). Adding lower value pull-up resistors will effect  $V_{OL}$  levels, however. The internal pull-ups of the BCT0102 are disabled when the OE pin is low.

### Typical Application Circuit

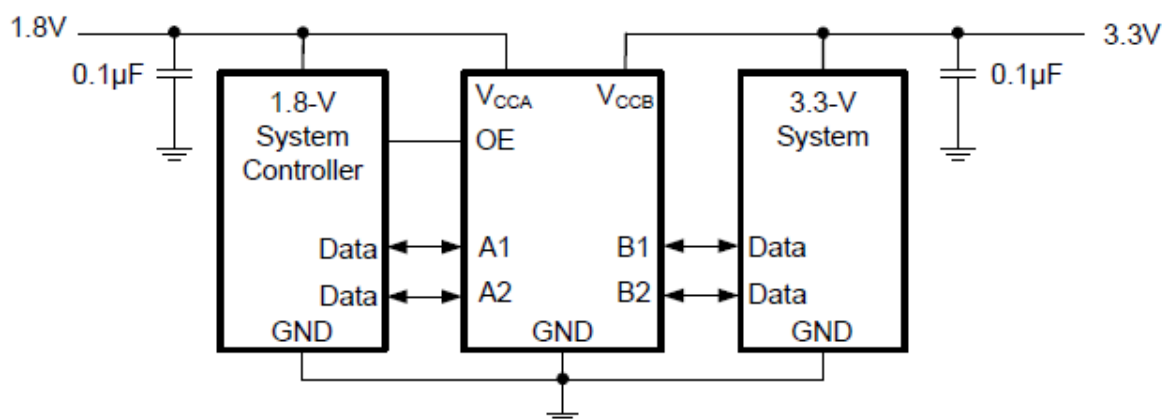

**Figure 2 Typical Application Circuit**

### Test Circuits

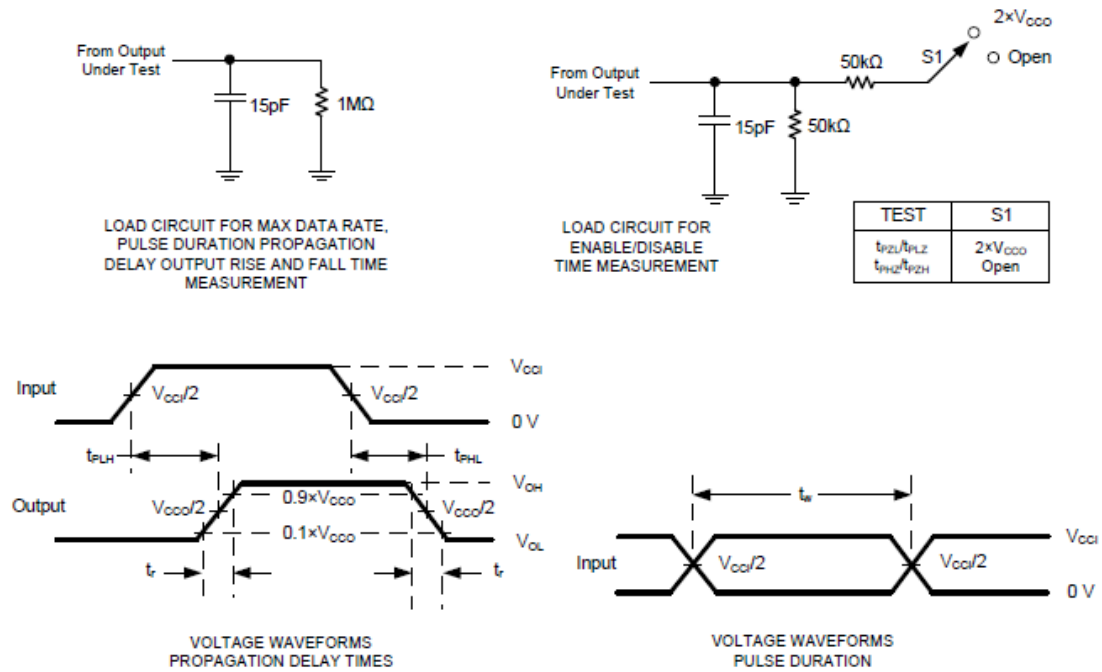

- A.  $C_L$  includes probe and jig capacitance.
- B. All input pulses are supplied by generators having the following characteristics: PRR $\leq$ 10MHz,  $Z_o=50\Omega$ ,  $dv/dt\geq 1V/ns$ .
- C. The outputs are measured one at a time, with one transition per measurement.
- D.  $t_{PLH}$  and  $t_{PHL}$  are the same as  $t_{PZ}$ .
- E.  $V_{CCi}$  is the  $V_{CC}$  associated with the input port.
- F.  $V_{CCo}$  is the  $V_{CC}$  associated with the output port.
- G. All parameters and waveforms are not applicable to all devices.

**Figure 3 Load Circuits and Voltage Waveforms**

### PACKAGE OUTLINE DIMENSIONS

TSOT23-8

Outline Drawing

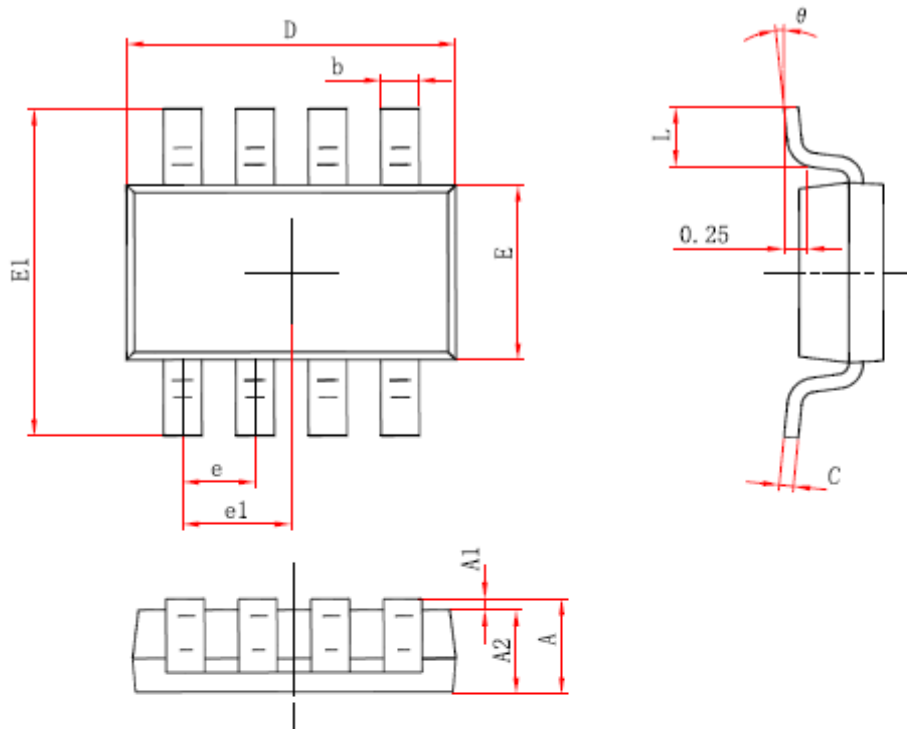

| Symbol | Dimensions In Millimeters |       | Dimensions In Inches |       |
|--------|---------------------------|-------|----------------------|-------|
|        | Min                       | Max   | Min                  | Max   |
| A      | 0.700                     | 0.900 | 0.028                | 0.035 |
| A1     | 0.000                     | 0.100 | 0.000                | 0.004 |
| A2     | 0.700                     | 0.800 | 0.028                | 0.031 |
| b      | 0.300                     | 0.400 | 0.012                | 0.016 |
| c      | 0.080                     | 0.200 | 0.003                | 0.008 |
| D      | 2.820                     | 3.020 | 0.111                | 0.119 |
| E      | 1.600                     | 1.700 | 0.063                | 0.067 |
| E1     | 2.650                     | 2.950 | 0.104                | 0.116 |
| e      | 0.65 (BSC)                |       | 0.026(BSC)           |       |
| e1     | 0.975 (BSC)               |       | 0.038(BSC)           |       |
| L      | 0.300                     | 0.600 | 0.012                | 0.024 |
| θ      | 0°                        | 8°    | 0°                   | 8°    |

**XTDFN1.4X1.0-8L**

**Outline Drawing**

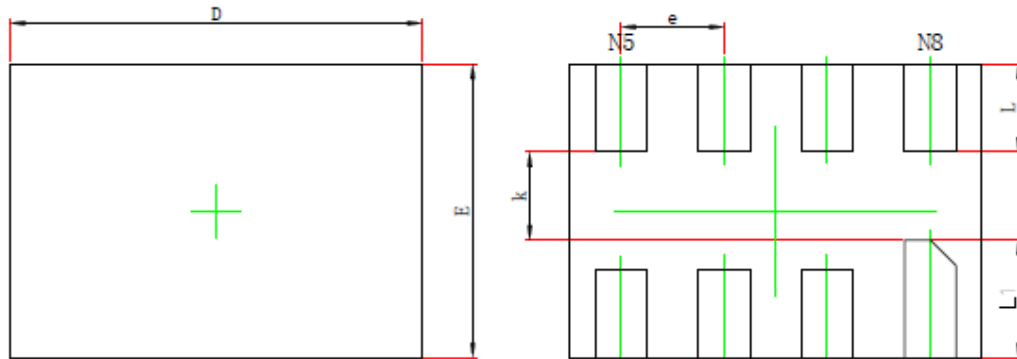

TOP VIEW

BOTTOM VIEW

SIDE VIEW

| Symbol | Dimensions In Millimeters |       | Dimensions In Inches |       |
|--------|---------------------------|-------|----------------------|-------|
|        | Min.                      | Max.  | Min.                 | Max.  |
| A      | 0.340                     | 0.400 | 0.013                | 0.016 |
| A1     | 0.000                     | 0.050 | 0.000                | 0.002 |
| A3     | 0.100REF.                 |       | 0.004REF.            |       |
| D      | 1.350                     | 1.450 | 0.053                | 0.057 |
| E      | 0.950                     | 1.050 | 0.037                | 0.041 |
| D1     | —                         | —     | —                    | —     |
| E1     | —                         | —     | —                    | —     |
| k      | 0.200MIN.                 |       | 0.008MIN.            |       |
| b      | 0.150                     | 0.200 | 0.006                | 0.008 |
| e      | 0.350TYP.                 |       | 0.014TYP.            |       |
| L      | 0.250                     | 0.350 | 0.010                | 0.014 |
| L1     | 0.350                     | 0.450 | 0.014                | 0.018 |



**QFN1.4X1.2-8L**  
**Outline Drawing**

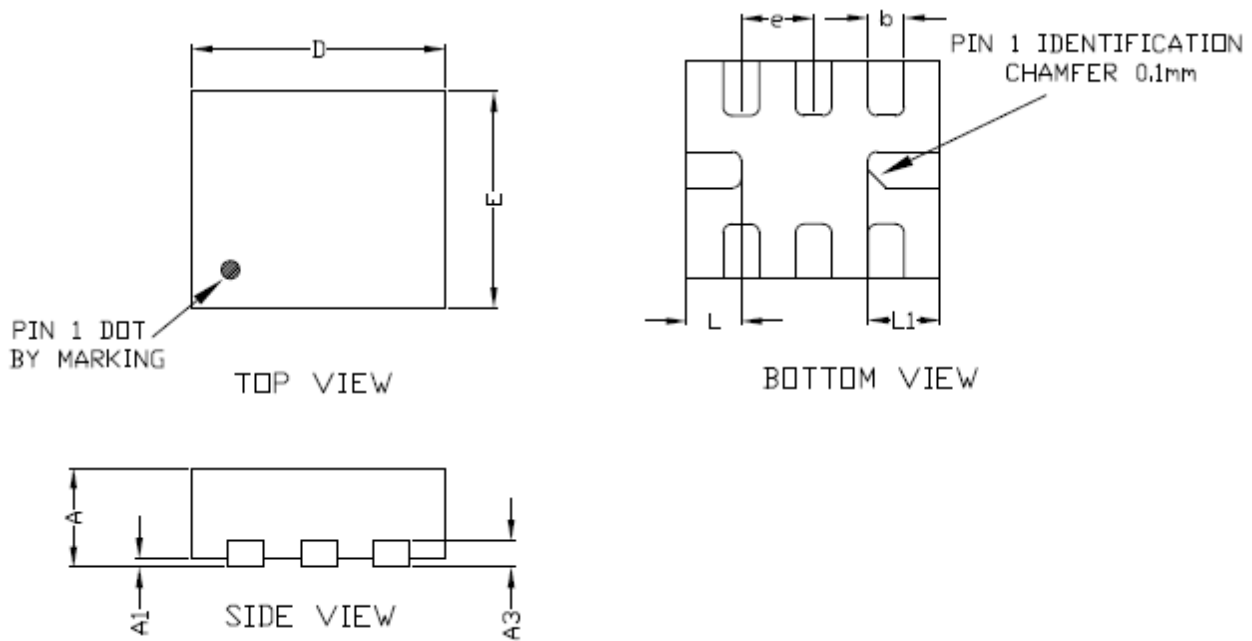

| COMMON DIMENSIONS(MM) |                |      |      |
|-----------------------|----------------|------|------|
| PKG.                  | UT:UL TRA THIN |      |      |
| REF.                  | MIN.           | NUM. | MAX  |
| A                     | 0.50           | 0.55 | 0.60 |
| A1                    | 0.00           | -    | 0.05 |
| A3                    | 0.15 REF.      |      |      |
| D                     | 1.35           | 1.40 | 1.45 |
| E                     | 1.15           | 1.20 | 1.25 |
| b                     | 0.15           | 0.20 | 0.25 |
| L                     | 0.20           | 0.30 | 0.40 |
| L1                    | 0.30           | 0.40 | 0.50 |
| e                     | 0.40 BSC       |      |      |