

## 54ACTQ/74ACTQ16245 16-Bit Transceiver with TRI-STATE® Outputs

### General Description

The 'ACTQ16245 contains sixteen non-inverting bidirectional buffers with TRI-STATE outputs and is intended for bus oriented applications. The device is byte controlled. Each has separate control inputs which can be shorted together for full 16-bit operation. The  $T/\bar{R}$  inputs determine the direction of data flow through the device. The  $\overline{OE}$  inputs disable both the A and B ports by placing them in a high impedance state.

The 'ACTQ16245 utilizes NSC Quiet Series technology to guarantee quiet output switching and improved dynamic threshold performance. FACT Quiet Series™ features GTO™ output control for superior performance.

### Features

- Utilizes NSC FACT Quiet Series technology
- Guaranteed simultaneous switching noise level and dynamic threshold performance
- Guaranteed pin-to-pin output skew
- Bidirectional non-inverting buffers
- Separate control logic for each byte
- 16-bit version of the 'ACTQ245
- Outputs source/sink 24 mA
- Additional specs for multiple output switching
- Output loading specs for both 50 pF and 250 pF loads

### Logic Symbol

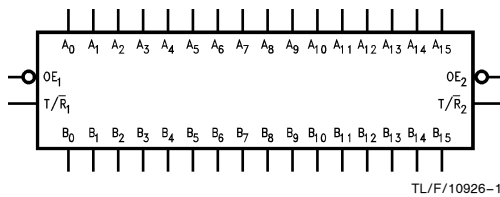

### Pin Description

Pin Names	Description
$\overline{OE}_n$	Output Enable Input (Active Low)
$T/\bar{R}$	Transmit/Receive Input
$A_0-A_{15}$	Side A Inputs/Outputs
$B_0-B_{15}$	Side B Outputs/Inputs

### Connection Diagram

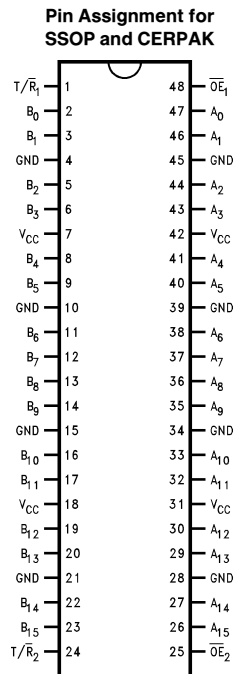

TRI-STATE® is a registered trademark of National Semiconductor Corporation.  
FACT™, FACT Quiet Series™ and GTO™ are trademarks of National Semiconductor Corporation.

## Functional Description

The 'ACTQ16245 contains sixteen non-inverting bidirectional buffers with TRI-STATE outputs. The device is byte controlled with each byte functioning identically, but independent of the other. The control pins can be shorted together to obtain full 16-bit operation. The following description applies to each byte. When the  $T/\bar{R}$  input is HIGH, then Bus A data is transmitted to Bus B. When the  $T/\bar{R}$  input is

LOW, Bus B data is transmitted to Bus A. The TRI-STATE outputs are controlled by an Output Enable ( $\overline{OE}_n$ ) input for each byte. When  $\overline{OE}_n$  is LOW, the outputs are in 2-state mode. When  $\overline{OE}_n$  is HIGH, the outputs are in the high impedance mode, but this does not interfere with entering new data into the inputs.

## Truth Tables

Inputs		Outputs
$\overline{OE}_1$	$T/\bar{R}_1$	
L	L	Bus B <sub>0</sub> –B <sub>7</sub> Data to Bus A <sub>0</sub> –A <sub>7</sub>
L	H	Bus A <sub>0</sub> –A <sub>7</sub> Data to Bus B <sub>0</sub> –B <sub>7</sub>
H	X	HIGH-Z State on A <sub>0</sub> –A <sub>7</sub> , B <sub>0</sub> –B <sub>7</sub>

Inputs		Outputs
$\overline{OE}_2$	$T/\bar{R}_2$	
L	L	Bus B <sub>8</sub> –B <sub>15</sub> Data to Bus A <sub>8</sub> –A <sub>15</sub>
L	H	Bus A <sub>8</sub> –A <sub>15</sub> Data to Bus B <sub>8</sub> –B <sub>15</sub>
H	X	HIGH-Z State on A <sub>8</sub> –A <sub>15</sub> , B <sub>8</sub> –B <sub>15</sub>

H = High Voltage Level  
 L = Low Voltage Level  
 X = Immaterial  
 Z = High Impedance

## Logic Diagram

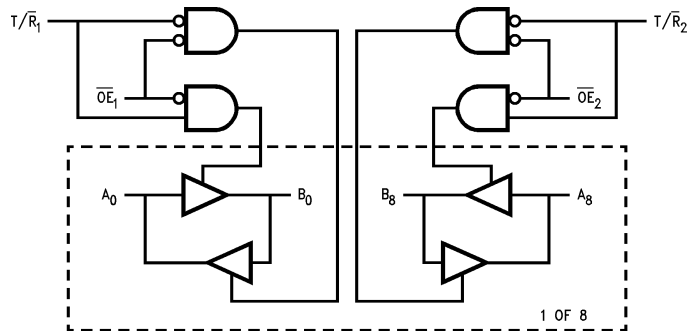

TL/F/10926-1

## Absolute Maximum Ratings (Note 1)

If Military/Aerospace specified devices are required, please contact the National Semiconductor Sales Office/Distributors for availability and specifications.

Supply Voltage ( $V_{CC}$ )	-0.5V to + 7.0V
DC Input Diode Current ( $I_{IK}$ )	-20 mA
$V_I = -0.5V$	-20 mA
$V_I = V_{CC} + 0.5V$	+20 mA
DC Output Diode Current ( $I_{OK}$ )	-20 mA
$V_O = -0.5V$	-20 mA
$V_O = V_{CC} + 0.5V$	+20 mA
DC Output Voltage ( $V_O$ )	-0.5V to $V_{CC} + 0.5V$
DC Output Source/Sink Current ( $I_O$ )	± 50 mA
DC $V_{CC}$ or Ground Current per Output Pin	± 50 mA
Junction Temperature	
C-DIP	+ 175°C
PDIP/SOIC	+ 140°C
Storage Temperature	-65°C to +150°C

**Note 1:** Absolute maximum ratings are those values beyond which damage to the device may occur. The databook specifications should be met, without exception to ensure that the system design is reliable over its power supply, temperature, and output/input loading variables. National does not recommend operation of FACT™ circuits outside databook specifications.

**Note 2:** For qualification information please refer to the NSC SSOP Qualification Handbook.

## Recommended Operating Conditions

Supply Voltage ( $V_{CC}$ )	4.5V to 5.5V
'ACTQ	
Input Voltage ( $V_I$ )	0V to $V_{CC}$
Output Voltage ( $V_O$ )	0V to $V_{CC}$
Operating Temperature ( $T_A$ )	
74ACTQ	-40°C to +85°C
54ACTQ	-55°C to +125°C
Minimum Input Edge Rate (dV/dt)	
'ACTQ Devices	125 mV/ns
$V_{IN}$ from 0.8V to 2.0V	
$V_{CC}$ @ 4.5V, 5.5V	

## DC Electrical Characteristics for 'ACTQ Family Devices

Symbol	Parameter	$V_{CC}$ (V)	74ACTQ		54ACTQ		74ACTQ		Units	Conditions
			$T_A = +25^\circ\text{C}$		$T_A = -55^\circ\text{C to } +125^\circ\text{C}$		$T_A = -40^\circ\text{C to } +85^\circ\text{C}$			
			Typ	Guaranteed Limits						
$V_{IH}$	Minimum High Input Voltage	4.5	1.5	2.0	2.0	2.0	2.0	2.0	V	$V_{OUT} = 0.1V$ or $V_{CC} - 0.1V$
		5.5	1.5	2.0	2.0	2.0	2.0	2.0		
$V_{IL}$	Maximum Low Input Voltage	4.5	1.5	0.8	0.8	0.8	0.8	0.8	V	$V_{OUT} = 0.1V$ or $V_{CC} - 0.1V$
		5.5	1.5	0.8	0.8	0.8	0.8	0.8		
$V_{OH}$	Minimum High Output Voltage	4.5	4.49	4.4	4.4	4.4	4.4	4.4	V	$I_{OUT} = -50 \mu\text{A}$
		5.5	5.49	5.4	5.4	5.4	5.4	5.4		
		4.5		3.86	3.70	3.76	3.76	3.76	V	$V_{IN}^* = V_{IL}$ or $V_{IH}$ -24 mA -24 mA
		5.5		4.86	4.70	4.76	4.76	4.76		
$V_{OL}$	Maximum Low Output Voltage	4.5	0.001	0.1	0.1	0.1	0.1	0.1	V	$I_{OUT} = 50 \mu\text{A}$
		5.5	0.001	0.1	0.1	0.1	0.1	0.1		
		4.5		0.36	0.50	0.44	0.44	0.44	V	$V_{IN}^* = V_{IL}$ or $V_{IH}$ 24 mA 24 mA
		5.5		0.36	0.50	0.50	0.44	0.44		
$I_{OZT}$	Maximum I/O Leakage Current	5.5		±0.5	±10.0	±5.0	±5.0	±5.0	μA	$V_I = V_{IL}, V_{IH}$ $V_O = V_{CC}, \text{GND}$
$I_{IN}$	Maximum Input Leakage Current	5.5		±0.1	±1.0	±1.0	±1.0	±1.0	μA	$V_I = V_{CC}, \text{GND}$
$I_{CCT}$	Maximum $I_{CC}$ /Input	5.5	0.6		1.6	1.5	1.5	1.5	mA	$V_I = V_{CC} - 2.1V$
$I_{CC}$	Max Quiescent Supply Current	5.5		8.0	160.0	80.0	80.0	80.0	μA	$V_{IN} = V_{CC}$ or GND (Note 5)
$I_{OLD}$	†Minimum Dynamic Output Current	5.5			50	75	75	75	mA	$V_{OLD} = 1.65V$ Max
$I_{OHD}$					50	-75	-75	-75	mA	$V_{OHD} = 3.85V$ Min

\* All outputs loaded; thresholds associated with output under test.

†Maximum test duration 2.0 ms; one output loaded at a time.

## DC Electrical Characteristics for 'ACTQ Family Devices (Continued)

Symbol	Parameter	V <sub>CC</sub> (V)	74ACTQ		54ACTQ	74ACTQ	Units	Conditions
			T <sub>A</sub> = +25°C		T <sub>A</sub> = -55°C to +125°C	T <sub>A</sub> = -40°C to +85°C		
			Typ	Guaranteed Limits				
V <sub>OLP</sub>	Quiet Output Maximum Dynamic V <sub>OL</sub>	5.0	0.5	0.8			V	Figures 2-12, 13 (Notes 2, 3)
V <sub>OLV</sub>	Quiet Output Minimum Dynamic V <sub>OL</sub>	5.0	-0.5	-0.85			V	Figures 2-12, 13 (Notes 2, 3)
V <sub>OHP</sub>	Maximum Overshoot	5.0	V <sub>OH</sub> + 1.0	V <sub>OH</sub> + 1.5			V	Figures 2-12, 13 (Notes 1, 3)
V <sub>OHV</sub>	Minimum V <sub>CC</sub> Droop	5.0	V <sub>OH</sub> - 1.0	V <sub>OH</sub> - 1.8			V	Figures 2-12, 13 (Notes 1, 3)
V <sub>IHD</sub>	Minimum High Dynamic Input Voltage Level	5.0	1.7	2.0			V	(Notes 1, 4)
V <sub>ILD</sub>	Maximum Low Dynamic Input Voltage Level	5.0	1.2	0.8			V	(Notes 1, 4)

**Note 1:** Worst case package.

**Note 2:** Maximum number of outputs that can switch simultaneously is n. (n - 1) outputs are switched LOW and one output held LOW.

**Note 3:** Maximum number of outputs that can switch simultaneously is n. (n - 1) outputs are switched HIGH and one output held HIGH.

**Note 4:** Max number of data inputs (n) switching. (n - 1) input switching 0V to 3V ('ACTQ) input under test switching 3V to threshold (V<sub>ILD</sub>)

**Note 5:** I<sub>CC</sub> for 54ACTQ @ 25°C is identical to 74ACTQ @ 25°C.

## AC Electrical Characteristics

Symbol	Parameter	V <sub>CC</sub> * (V)	74ACTQ			54ACTQ		74ACTQ		Units
			T <sub>A</sub> = +25°C C <sub>L</sub> = 50 pF			T <sub>A</sub> = -55°C to +125°C C <sub>L</sub> = 50 pF		T <sub>A</sub> = -40°C to +85°C C <sub>L</sub> = 50 pF		
			Min	Typ	Max	Min	Max	Min	Max	
t <sub>PLH</sub> , t <sub>PHL</sub>	Propagation Delay A <sub>n</sub> , B <sub>n</sub> to B <sub>n</sub> , A <sub>n</sub>	5.0	3.2 2.6	5.7 5.1	8.4 7.9	3.2 2.6	9.4 8.7	3.2 2.6	9.0 8.4	ns
t <sub>PZH</sub> , t <sub>PZL</sub>	Output Enable Time	5.0	3.7 4.1	6.4 7.4	9.4 10.5	3.7 4.1		2.7 3.4	10.0 11.6	ns
t <sub>PHZ</sub> , t <sub>PLZ</sub>	Output Disable Time	5.0	2.2 2.0	5.4 5.2	8.7 8.2	2.2 2.0	9.5 9.1	2.2 2.0	9.3 8.8	ns

\* Voltage Range 5.0 is 5.0V ± 0.5V.

## Extended AC Electrical Characteristics

Symbol	Parameter	74ACTQ			54ACTQ		74ACTQ		54ACTQ		Units
		T <sub>A</sub> = -40°C to +85°C V <sub>CC</sub> = Com C <sub>L</sub> = 50 pF 16 Outputs Switching (Note 2)			T <sub>A</sub> = Mil V <sub>CC</sub> = Mil C <sub>L</sub> = 50 pF 16 Outputs Switching (Note 2)		T <sub>A</sub> = -40°C to +85°C V <sub>CC</sub> = Com C <sub>L</sub> = 250 pF (Note 3)		T <sub>A</sub> = Mil V <sub>CC</sub> = Mil C <sub>L</sub> = 250 pF (Note 3)		
		Min	Typ	Max	Min	Max	Min	Max	Min	Max	
t <sub>PLH</sub>	Propagation Delay	4.2		11.9	4.2	12.5	5.9	14.6	5.9	15.3	ns
t <sub>PHL</sub>	Data to Output	3.5		9.9	3.5	10.3	5.0	13.4	5.0	13.9	
t <sub>pZH</sub>	Output Enable Time	4.5		11.4	4.5	12.2	(Note 4)		(Note 4)		ns
t <sub>pZL</sub>		4.4		12.2	4.4	13.0	(Note 4)		(Note 4)		
t <sub>PHZ</sub>	Output Disable Time	3.5		9.3	3.5	9.5	(Note 5)		(Note 5)		ns
t <sub>pZL</sub>		3.1		8.8	3.1	9.1	(Note 5)		(Note 5)		
t <sub>OSSL</sub> (Note 1)	Pin to Pin Skew HL Data to Output			1.2							ns
t <sub>OSLH</sub> (Note 1)	Pin to Pin Skew LH Data to Output			1.3							ns
t <sub>OSt</sub> (Note 1)	Pin to Pin Skew LH/HL Data to Output			3.0							ns

**Note 1:** Skew is defined as the absolute value of the difference between the actual propagation delays for any two separate outputs of the same device. The specification applies to any outputs switching HIGH to LOW (t<sub>OSSL</sub>), LOW to HIGH (t<sub>OSLH</sub>), or any combination switching LOW to HIGH and/or HIGH to LOW (t<sub>OSt</sub>).

**Note 2:** This specification is guaranteed but not tested. The limits apply to propagation delays for all paths described switching in phase (i.e., all low-to-high, high-to-low, etc.).

**Note 3:** This specification is guaranteed but not tested. The limits represent propagation delays with 250 pF load capacitors in place of the 50 pF load capacitors in the standard AC load. This specification pertains to single output switching only.

**Note 4:** TRI-STATE delays are load dominated and have been excluded from the datasheet.

**Note 5:** The Output Disable Time is dominated by the RC network (500Ω, 250 pF) on the output and has been excluded from the datasheet.

## Capacitance

Symbol	Parameter	Typ	Units	Conditions	
C <sub>IN</sub>	Input Pin Capacitance	4.5	pF	V <sub>CC</sub> = 5.0V	
C <sub>PD</sub>	Power Dissipation Capacitance	74ACTQ	25	pF	V <sub>CC</sub> = 5.0V
		54ACTQ	95	pF	V <sub>CC</sub> = 5.0V

## FACT Noise Characteristics

The setup of a noise characteristics measurement is critical to the accuracy and repeatability of the tests. The following is a brief description of the setup used to measure the noise characteristics of FACT.

### Equipment:

Hewlett Packard Model 8180A Word Generator  
PC-163A Test Fixture  
Tektronics Model 7854 Oscilloscope

### Procedure:

1. Verify Test Fixture Loading: Standard Load 50 pF, 500Ω.
2. Deskew the word generator so that no two channels have greater than 150 ps skew between them. This requires that the oscilloscope be deskewed first. Swap out the channels that have more than 150 ps of skew until all channels being used are within 150 ps. It is important to deskew the word generator channels before testing. This will ensure that the outputs switch simultaneously.
3. Terminate all inputs and outputs to ensure proper loading of the outputs and that the input levels are at the correct voltage.
4. Set  $V_{CC}$  to 5.0V.
5. Set the word generator to toggle all but one output at a frequency of 1 MHz. Greater frequencies will increase DUT heating and affect the results of the measurement.

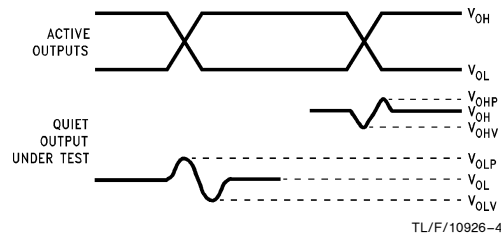

**FIGURE 1. Quiet Output Noise Voltage Waveforms**

**Note A:**  $V_{OHPV}$  and  $V_{OLP}$  are measured with respect to ground reference.

**Note B:** Input pulses have the following characteristics:  $f = 1$  MHz,  $t_r = 3$  ns,  $t_f = 3$  ns, skew < 150 ps.

6. Set the word generator input levels at 0V LOW and 3V HIGH for ACT devices and 0V LOW and 5V HIGH for AC devices. Verify levels with a digital volt meter.

### $V_{OLP}/V_{OLV}$ and $V_{OHP}/V_{OHPV}$ :

- Determine the quiet output pin that demonstrates the greatest noise levels. The worst case pin will usually be the furthest from the ground pin. Monitor the output voltages using a 50Ω coaxial cable plugged into a standard SMB type connector on the test fixture. Do not use an active FET probe.
- Measure  $V_{OLP}$  and  $V_{OLV}$  on the quiet output during the HL transition. Measure  $V_{OHP}$  and  $V_{OHPV}$  on the quiet output during the LH transition.
- Verify that the GND reference recorded on the oscilloscope has not drifted to ensure the accuracy and repeatability of the measurements.

### $V_{ILD}$ and $V_{IHD}$ :

- Monitor one of the switching outputs using a 50Ω coaxial cable plugged into a standard SMB type connector on the test fixture. Do not use an active FET probe.
- First increase the input LOW voltage level,  $V_{IL}$ , until the output begins to oscillate. Oscillation is defined as noise on the output LOW level that exceeds  $V_{IL}$  limits, or on output HIGH levels that exceed  $V_{IH}$  limits. The input LOW voltage level at which oscillation occurs is defined as  $V_{ILD}$ .
- Next increase the input HIGH voltage level on the word generator,  $V_{IH}$  until the output begins to oscillate. Oscillation is defined as noise on the output LOW level that exceeds  $V_{IL}$  limits, or on output HIGH levels that exceed  $V_{IH}$  limits. The input HIGH voltage level at which oscillation occurs is defined as  $V_{IHD}$ .
- Verify that the GND reference recorded on the oscilloscope has not drifted to ensure the accuracy and repeatability of the measurements.

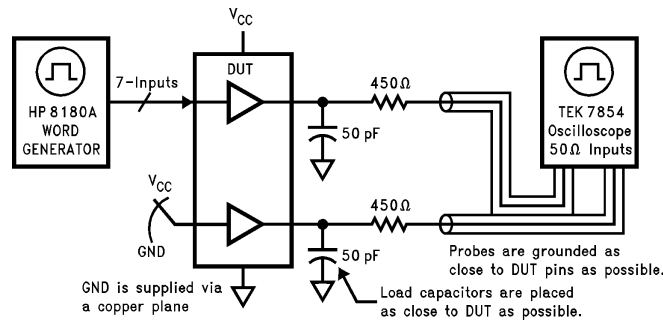

**FIGURE 2. Simultaneous Switching Test Circuit**

## Ordering Information

The device number is used to form part of a simplified purchasing code where the package type and temperature range are defined as follows:

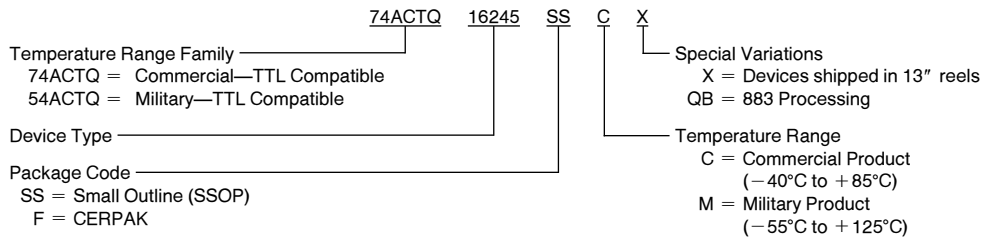

## Physical Dimensions inches (millimeters)

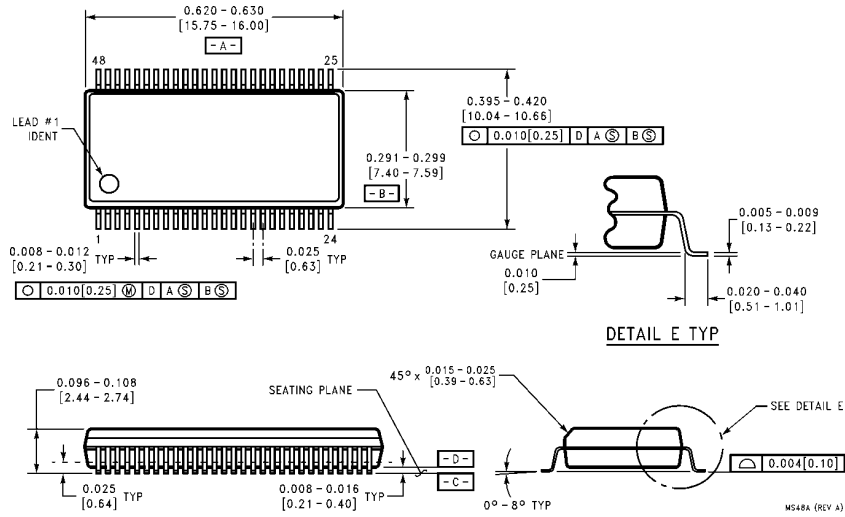

**48-Lead SSOP (0.300" Wide) (SS)**  
**NS Package Number MS48A**

**Physical Dimensions** (Continued)

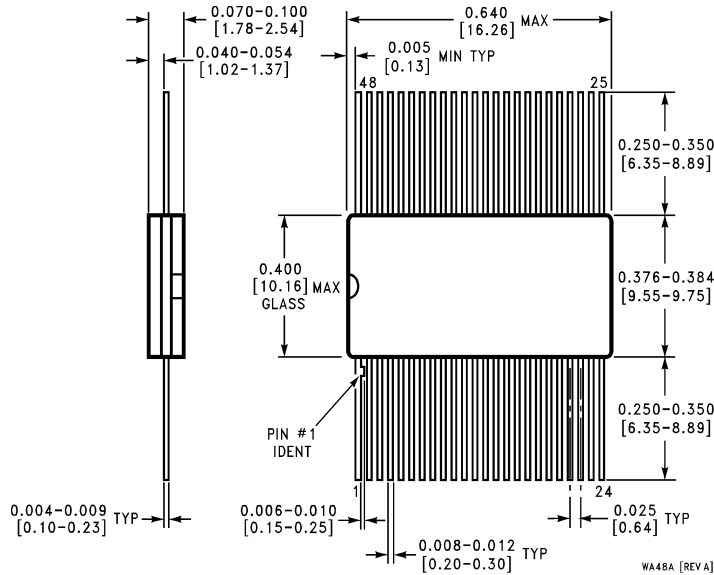

**48-Lead CERPAK (F)  
NS Package Number WA48A**

**LIFE SUPPORT POLICY**

NATIONAL'S PRODUCTS ARE NOT AUTHORIZED FOR USE AS CRITICAL COMPONENTS IN LIFE SUPPORT DEVICES OR SYSTEMS WITHOUT THE EXPRESS WRITTEN APPROVAL OF THE PRESIDENT OF NATIONAL SEMICONDUCTOR CORPORATION. As used herein:

1. Life support devices or systems are devices or systems which, (a) are intended for surgical implant into the body, or (b) support or sustain life, and whose failure to perform, when properly used in accordance with instructions for use provided in the labeling, can be reasonably expected to result in a significant injury to the user.
2. A critical component is any component of a life support device or system whose failure to perform can be reasonably expected to cause the failure of the life support device or system, or to affect its safety or effectiveness.



**National Semiconductor Corporation**  
2900 Semiconductor Drive  
P.O. Box 58090  
Santa Clara, CA 95052-8090  
Tel: 1(800) 272-9959  
TWX: (910) 339-9240

**National Semiconductor GmbH**  
Livny-Gargan-Str. 10  
D-82256 Fürstenfeldbruck  
Germany  
Tel: (81-41) 35-0  
Telex: 527849  
Fax: (81-41) 35-1

**National Semiconductor Japan Ltd.**  
Sumitomo Chemical  
Engineering Center  
Bldg. 7F  
1-7-1, Nakase, Mihama-Ku  
Chiba-City,  
Ciba Prefecture 261  
Tel: (043) 299-2300  
Fax: (043) 299-2500

**National Semiconductor Hong Kong Ltd.**  
13th Floor, Straight Block,  
Ocean Centre, 5 Canton Rd.  
Tsimshatsui, Kowloon  
Hong Kong  
Tel: (852) 2737-1600  
Fax: (852) 2736-9960

**National Semicondutores Do Brazil Ltda.**  
Rue Deputado Lacorda Franco  
120-3A  
Sao Paulo-SP  
Brazil 05418-000  
Tel: (55-11) 212-5066  
Telex: 391-1131931 NSBR BR  
Fax: (55-11) 212-1181

**National Semiconductor (Australia) Pty. Ltd.**  
Building 16  
Business Park Drive  
Monash Business Park  
Nottingham, Melbourne  
Victoria 3168 Australia  
Tel: (3) 558-9999  
Fax: (3) 558-9998

National does not assume any responsibility for use of any circuitry described, no circuit patent licenses are implied and National reserves the right at any time without notice to change said circuitry and specifications.



This datasheet has been download from:

[www.datasheetcatalog.com](http://www.datasheetcatalog.com)

Datasheets for electronics components.

# National Semiconductor was acquired by Texas Instruments.

[http://www.ti.com/corp/docs/investor\\_relations/pr\\_09\\_23\\_2011\\_national\\_semiconductor.html](http://www.ti.com/corp/docs/investor_relations/pr_09_23_2011_national_semiconductor.html)

This file is the datasheet for the following electronic components:

54ACTQ16245 - <http://www.ti.com/product/54actq16245?HQS=TI-null-null-dscatalog-df-pf-null-ww>

74ACTQ16245 - <http://www.ti.com/product/74actq16245?HQS=TI-null-null-dscatalog-df-pf-null-ww>