

ESD5344D
**4-Lines, Uni-directional, Ultra-low Capacitance
Transient Voltage Suppressors**
Descriptions

The ESD5344D is an ultra-low capacitance TVS (Transient Voltage Suppressor) array designed to protect high speed data interfaces. It has been specifically designed to protect sensitive electronic components which are connected to data and transmission lines from over-stress caused by ESD (Electrostatic Discharge).

The ESD5344D incorporates four pairs of ultra-low capacitance steering diodes plus a TVS diode.

The ESD5344D may be used to provide ESD protection up to $\pm 20\text{kV}$ (contact discharge) according to IEC61000-4-2, and withstand peak pulse current up to 4A (8/20 μs) according to IEC61000-4-5.

The ESD5344D is available in DFN2510-10L package. Standard products are Pb-free and Halogen-free.

Features

- Stand-off voltage: 5V max.
- Transient protection for each line according to IEC61000-4-2 (ESD): $\pm 20\text{kV}$ (contact discharge)
IEC61000-4-4 (EFT): 40A (5/50ns)
IEC61000-4-5 (surge): 4A (8/20 μs)
- Ultra-low capacitance: $C_J = 0.4\text{pF}$ typ.
- Ultra-low leakage current: $I_R < 1\text{nA}$ typ.
- Low clamping voltage: $V_{CL} = 14\text{V}$ typ. @ $I_{PP} = 16\text{A}$ (TLP)
- Solid-state silicon technology

Applications

- USB 2.0 and USB 3.0
- HDMI 1.3, HDMI 1.4 and HDMI 2.0
- SATA and eSATA
- DVI
- IEEE 1394
- PCI Express
- Portable Electronics and Notebooks

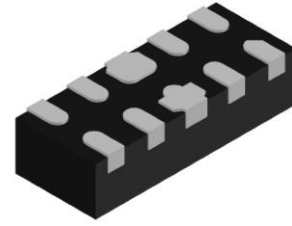
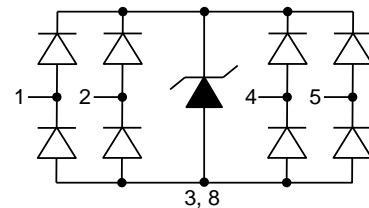
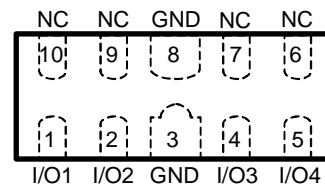
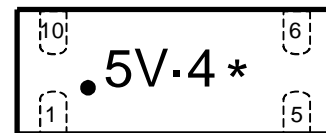
www.omnivision-group.com

DFN2510-10L (Bottom view)

Pin configuration (Top view)

5V-4 = Device code
* = Month code (A~Z)

Marking
Order information

Device	Package	Shipping
ESD5344D-10/TR	DFN2510-10L	3000/Tape&Reel

Absolute maximum ratings

Parameter	Symbol	Rating	Unit
Peak pulse power ($t_p = 8/20\mu s$)	P_{pk}	50	W
Peak pulse current ($t_p = 8/20\mu s$)	I_{PP}	4	A
ESD according to IEC61000-4-2 air discharge	V_{ESD}	± 20	kV
ESD according to IEC61000-4-2 contact discharge		± 20	
Junction temperature	T_J	125	$^{\circ}C$
Operating temperature	T_{OP}	-40~85	$^{\circ}C$
Lead temperature	T_L	260	$^{\circ}C$
Storage temperature	T_{STG}	-55~150	$^{\circ}C$

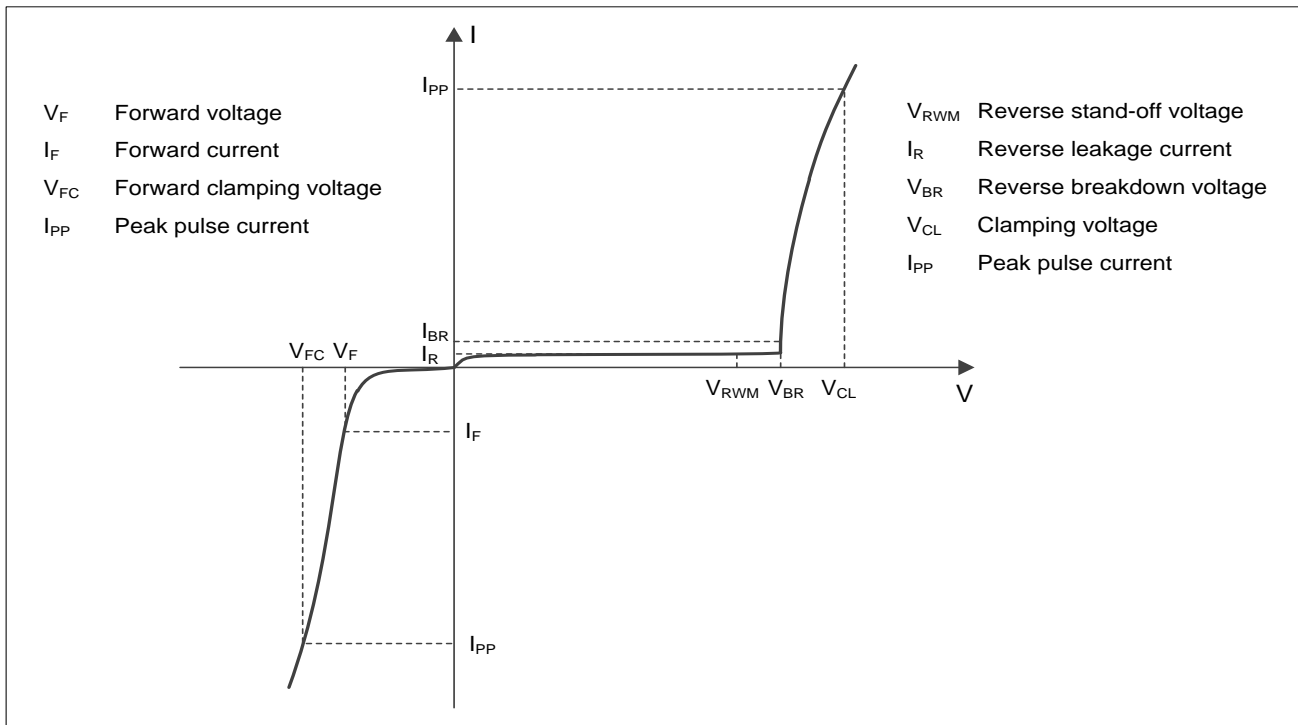
Electrical characteristics ($T_A=25^{\circ}C$, unless otherwise noted)

Definitions of electrical characteristics

Electrical characteristics ($T_A = 25^\circ\text{C}$, unless otherwise noted)

Parameter	Symbol	Condition	Min.	Typ.	Max.	Unit
Reverse maximum working voltage	V_{RWM}				5.0	V
Reverse leakage current	I_R	$V_{RWM} = 5V$		<1	100	nA
Reverse breakdown voltage	V_{BR}	$I_T = 1\text{mA}$	7.0	8.0	9.0	V
Forward voltage	V_F	$I_T = 10\text{mA}$	0.6	0.9	1.2	V
Clamping voltage ¹⁾	V_{CL}	$I_{PP} = 16A, t_p = 100\text{ns}$		14		V
Dynamic resistance ¹⁾	R_{DYN}			0.33		Ω
Clamping voltage ²⁾	V_{CL}	$V_{ESD} = +8\text{kV}$		14		V
Clamping voltage ³⁾	V_{CL}	$I_{PP} = 1A, t_p = 8/20\mu\text{s}$			10	V
		$I_{PP} = 4A, t_p = 8/20\mu\text{s}$			12	V
Junction capacitance	C_J	$V_R = 0V, f = 1\text{MHz}$ Any I/O pin to GND		0.40	0.65	pF
		$V_R = 0V, f = 1\text{MHz}$ Between any I/O pin		0.25	0.40	pF

Notes:

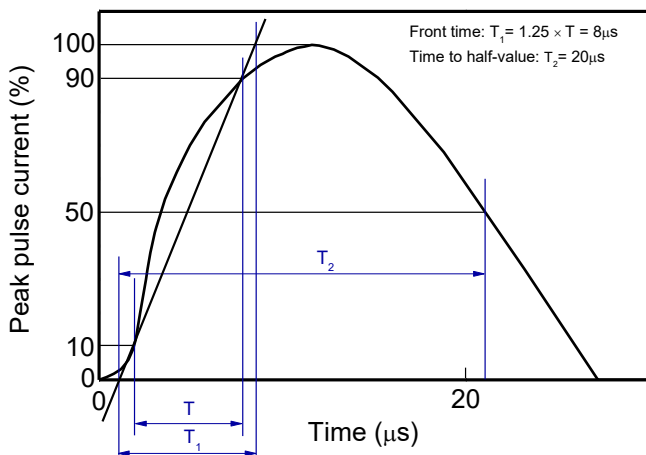
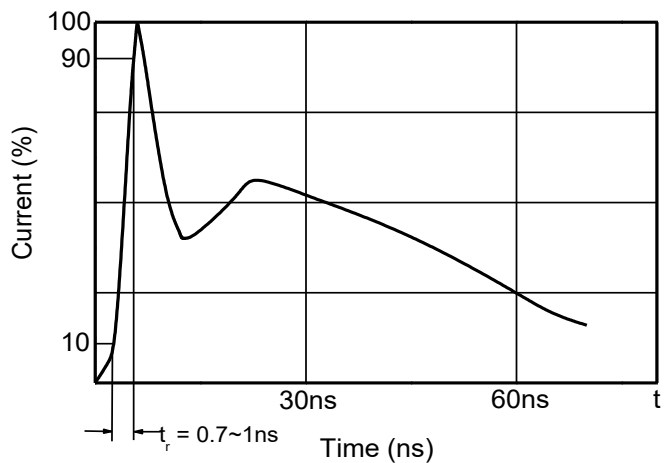
- 1) TLP parameter: $Z_0 = 50\ \Omega$, $t_p = 100\text{ns}$, $t_r = 2\text{ns}$, averaging window from 60ns to 80ns. R_{DYN} is calculated from 4A to 16A.
- 2) Contact discharge mode, according to IEC61000-4-2.
- 3) Non-repetitive current pulse, according to IEC61000-4-5.

8/20 μs waveform per IEC61000-4-5

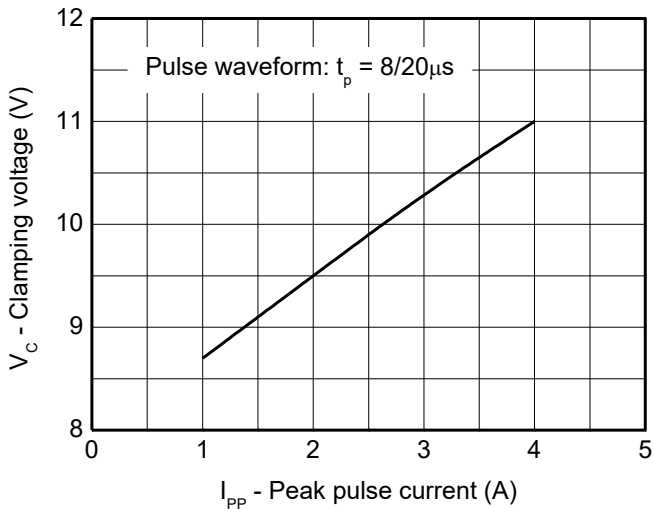
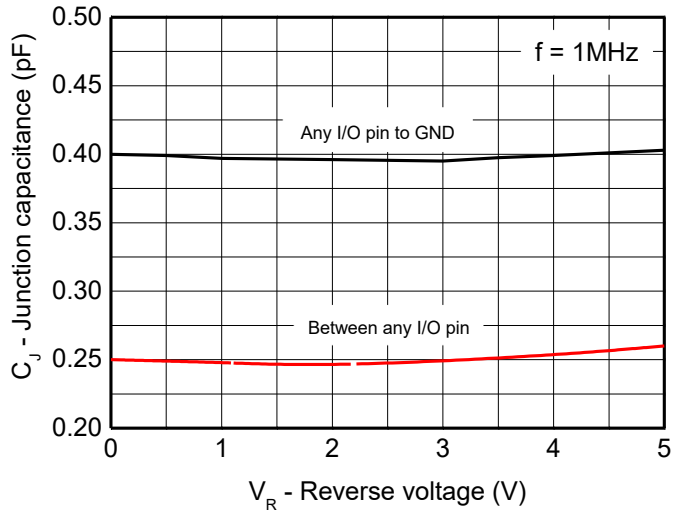
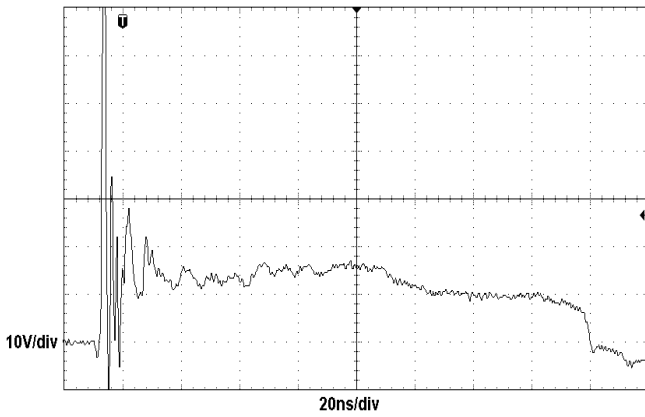
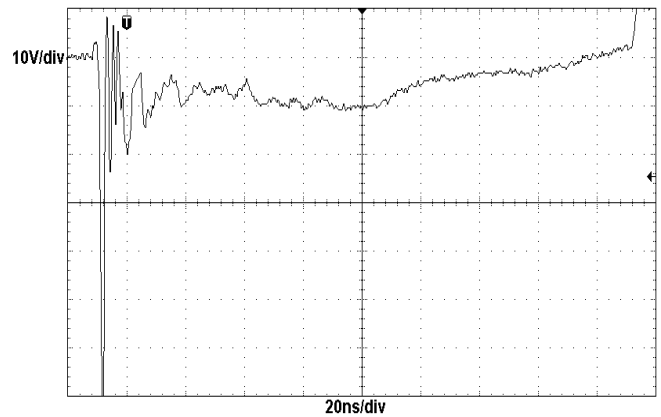
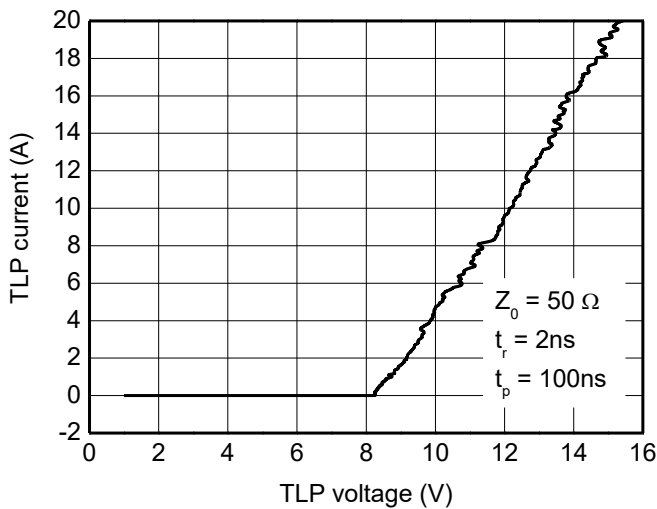
Contact discharge current waveform per IEC61000-4-2

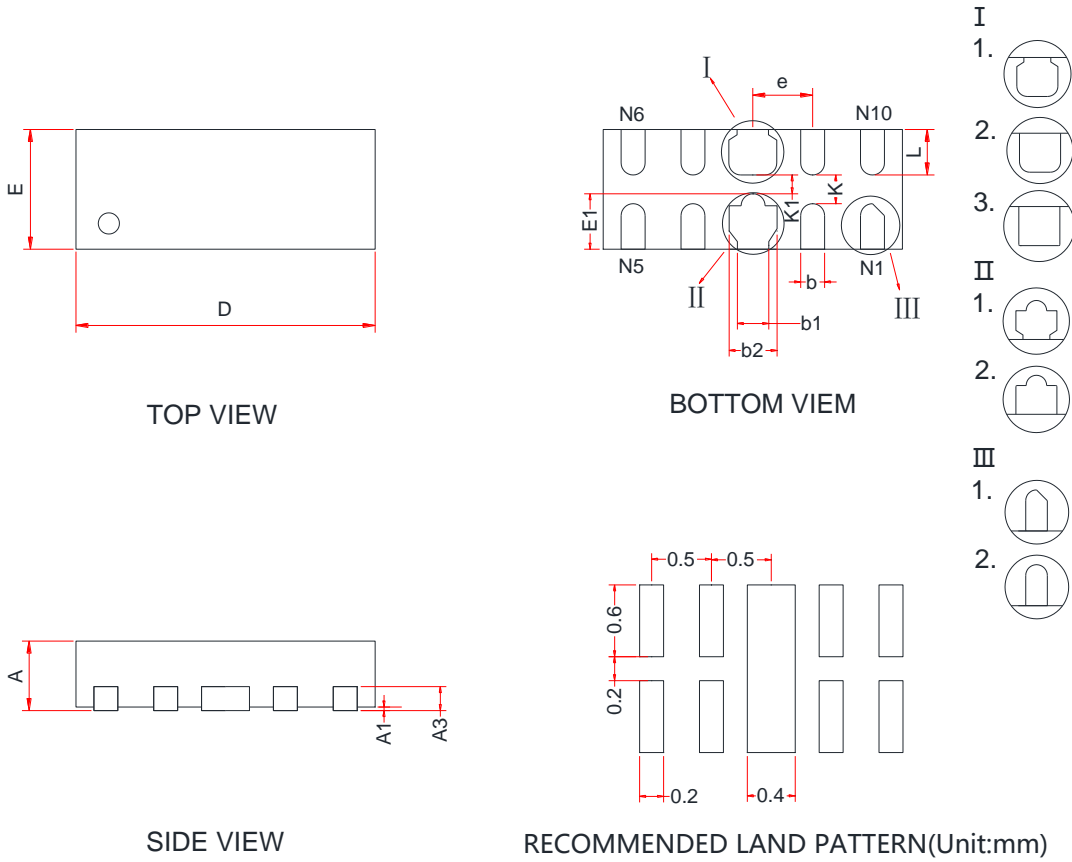
Typical characteristics ($T_A = 25^\circ\text{C}$, unless otherwise noted)

Clamping voltage vs. Peak pulse current

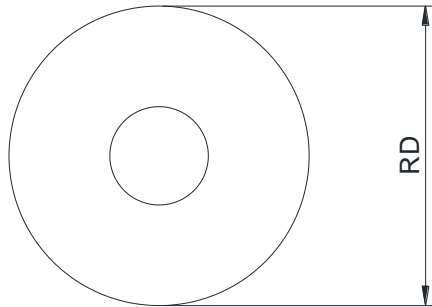
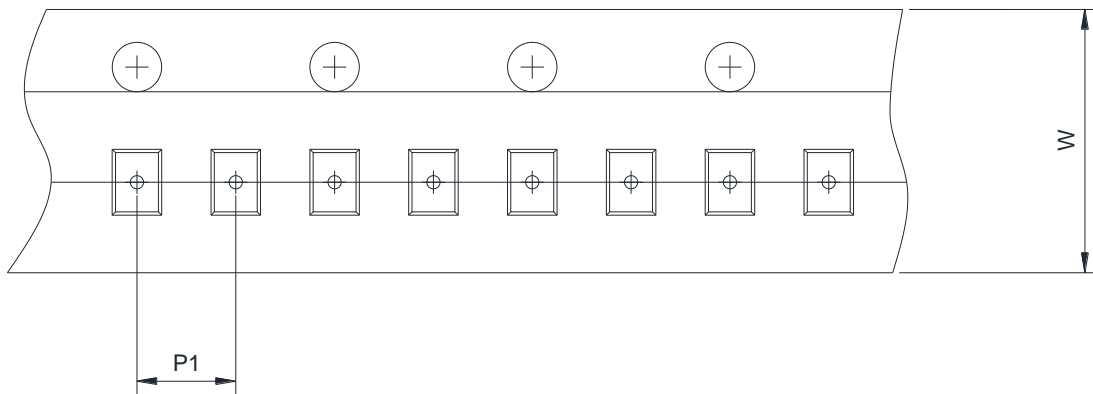
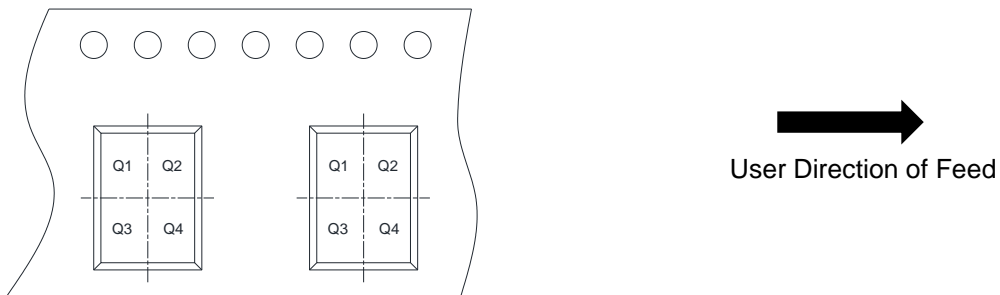
Capacitance vs. Reverse voltage

**ESD clamping
(+8kV contact discharge per IEC61000-4-2)**

**ESD clamping
(-8kV contact discharge per IEC61000-4-2)**

TLP Measurement

PACKAGE OUTLINE DIMENSIONS
DFN2510-10L

Symbol	Dimensions in Millimeters		
	Min.	Typ.	Max.
A	0.50	0.55	0.60
A1	0.00	0.02	0.05
A3	0.127 Ref.		
D	2.40	2.50	2.60
E	0.90	1.00	1.10
E1	0.300	-	0.56
b	0.15	0.20	0.25
b1	0.13	-	0.23
b2	0.35	0.40	0.45
e	0.50BSC		
L	0.28	0.39	0.50
K	0.20REF		
K1	0.11	-	-

TAPE AND REEL INFORMATION
Reel Dimensions

Tape Dimensions

Quadrant Assignments For PIN1 Orientation In Tape

RD	Reel Dimension	<input checked="" type="checkbox"/> 7inch	<input type="checkbox"/> 13inch		
W	Overall width of the carrier tape	<input checked="" type="checkbox"/> 8mm	<input type="checkbox"/> 12mm		
P1	Pitch between successive cavity centers	<input type="checkbox"/> 2mm	<input checked="" type="checkbox"/> 4mm	<input type="checkbox"/> 8mm	
Pin1	Pin1 Quadrant	<input checked="" type="checkbox"/> Q1	<input type="checkbox"/> Q2	<input type="checkbox"/> Q3	<input type="checkbox"/> Q4