

## 4-CH AUDIO POWER AMPLIFIER(8W X4)

### DESCRIPTION

SA7347 is a four channel audio amplifier including two non inverted amplifiers and two inverted amplifiers, so it can be conveniently applied in Bridge-Tied Load (BTL) mode.

Built-in protection circuit based on multiple temperature measurements inside SA7347 makes it possible for all supply voltages and load conditions to export maximum power.

### FEATURES

- \* Soft clip
- \* Standby and mute mode
- \* No on/off switching plops
- \* High supply voltage ripple rejection
- \* Thermally protected
- \* Outputs short circuit protected to ground, supply and across the load

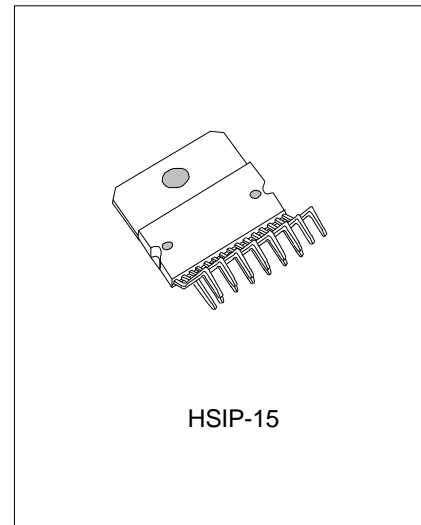

HSIP-15

### APPLICATIONS

- \* Television, PC speakers and mini stereo system, etc

### ORDERING INFORMATION

Device	Package
SA7347	HSIP-15

### BLOCK DIAGRAM

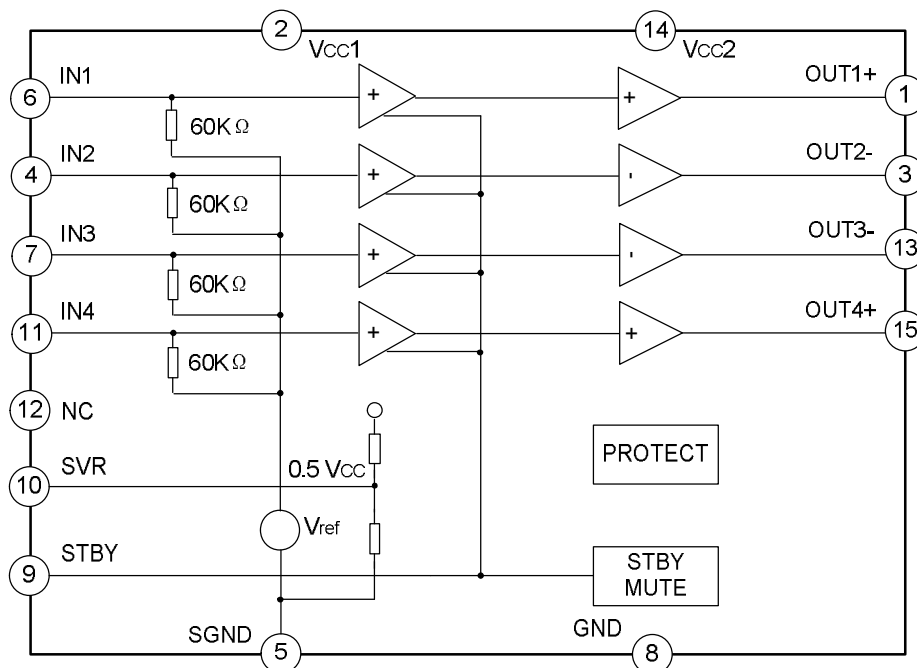

**ABSOLUTE MAXIMUM RATING** ( $T_{amb}=25^{\circ}C$ )

Characteristics	Symbol	Condition	Rating	Unit
Supply Voltage	VCC	Operating	-0.3 ~ +22	V
Input Voltage	VIN		-0.3 ~ VCC + 0.3	V
Repetitive Peak Output Current	IORM		4	A
Storage Temperature Range	Tstg	non-operating	-55 ~ +150	$^{\circ}C$
Ambient Temperature Range	Tamb		-40 ~ +85	$^{\circ}C$
Total Power Dissipation	Ptot		69	W
Supply Voltage to Guarantee Short-circuit Protection	VCC(SC)		17	V
Thermal Resistance From Junction to Ambient	Rth(j-a)	In free air	40	$^{\circ}C/W$
Thermal Resistance From Junction to Case	Rth(j-c)	All channels driven	1.3	$^{\circ}C/W$

**ELECTRICAL CHARACTERISTICS**

 (Unless otherwise stated,  $V_{CC}=15V$ ,  $R_{L(SE)}=4\Omega$ ,  $R_{L(BTL)}=8\Omega$ ,  $f=1kHz$ ,  $V_{stby}=V_{CC}$ ,  $T_{amb}=25^{\circ}C$ )

Characteristics	Symbol	Test condition	Min.	Typ.	Max.	Unit	
Quiescent Supply Current	Icq	$R_L=\infty$	--	100	145	mA	
Standby Supply Current	Istby		--	--	1	mA	
DC Output Voltage	Vo		--	6.9	--	V	
Differential Output Voltage Offset	$\Delta V_{OUT}$	BTL(*)	--	--	170	mV	
Select Voltage on Pin STBY	Vstby	play	$V_{CC}/2+3$	--	VCC	V	
		mute	4.5	--	$V_{CC}/2+2$		
		standby	0	--	0.8		
Select Current on Pin STBY	Ibias	$V_{CC}/2+2 < V_{stby} < V_{CC}$	--	--	20	$\mu A$	
Output power	Po	THD=10%, BTL, $R_L=4\Omega$	--	22	--	W	
		THD=10%	SE $R_L=3\Omega$	--	8		--
			SE $R_L=4\Omega$	--	6		--
			BTL $R_L=6\Omega$	--	17		--
			BTL $R_L=8\Omega$	--	13		--
		THD=1%	SE $R_L=3\Omega$	--	7		--
			SE $R_L=4\Omega$	--	5		--
			BTL $R_L=6\Omega$	--	14		--
BTL $R_L=8\Omega$	--		10	--			
Total Harmonic Distortion	THD	Po=1W	SE	--	0.1	0.5	%
			BTL	--	0.05	0.5	
Voltage Gain	Gv		SE	25	26	27	dB
			BTL	31	32	33	
Input Impedance	Zin		SE	40	60	--	K $\Omega$
			BTL	20	30	--	
Noise Output Voltage	Vn(o)		SE	--	150	--	$\mu V$
			BTL	--	200	--	

(To be continued)

(Continued)

Characteristics	Symbol	Test condition	Min.	Typ.	Max.	Unit	
Supply Voltage Ripple Rejection	SVRR	frip=1kHz(**)	SE	--	60	--	dB
			BTL	--	65	--	
		frip=100Hz~20kHz(**)	SE	--	60	--	dB
			BTL	--	65	--	
Output Voltage in Mute Mode	Vo(mute)		SE	--	--	150	μV
			BTL	--	--	250	
Channel Separation	CS	Rsource=0Ω	SE	50	60	--	dB
			BTL	50	65	--	
Channel Balance	CB		SE	--	--	1	dB
			BTL	--	--	1	

(\*)  $\Delta V_{OUT} = |V_{OUT+} - V_{OUT-}|$

(\*\*) Supply voltage ripple rejection is measured at the output, with a source impedance  $R_{source} = 0\Omega$  at the input and with a frequency range from 20 Hz to 22 KHz. The ripple voltage is a sine wave with a frequency fripple and an amplitude of 300 mVrms, which is applied to the positive supply rail.

#### Pin configurations

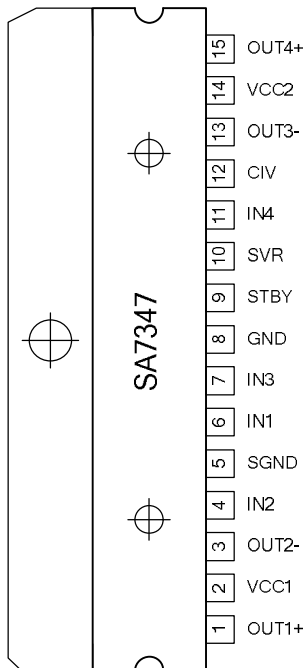

#### Pin descriptions

Pin No.	Pin Name	Description
1	OUT1+	non inverted loudspeaker output of channel 1
2	VCC1	supply voltage channels 1 and 2
3	OUT2-	inverted loudspeaker output of channel 2
4	IN2	input channel 2
5	SGND	signal ground
6	IN1	input channel 1
7	IN3	input channel 3
8	GND	power ground
9	STBY	mode selection input: standby, mute and play
10	SVR	half supply voltage ripple rejection
11	IN4	input channel 4
12	CIV	common input voltage ripple rejection
13	OUT3-	inverted loudspeaker output of channel 3
14	VCC2	supply voltage channels 1 and 2
15	OUT4+	non inverted loudspeaker output of channel 4

## FUNCTION DESCRIPTION

### Input configuration

The formula of the input cut-off frequency is:

$$f_{i(\text{cut-off})} = \frac{1}{2\pi(R_i \times C_i)}$$

For SE application  $R_{in} = 60\text{k}\Omega$  and  $C_{in} = 220\text{nF}$ :

$$f_{i(\text{cut-off})} = \frac{1}{2\pi(60 \times 10^3 \times 220 \times 10^{-9})} = 12\text{Hz}$$

For BTL application  $R_{in} = 30\text{k}\Omega$  and  $C_{in} = 470\text{nF}$ :

$$f_{i(\text{cut-off})} = \frac{1}{2\pi(30 \times 10^3 \times 470 \times 10^{-9})} = 11\text{Hz}$$

Because of high input impedance, large capacitor values for the inputs are not necessary. The smaller input capacitor values help to reduce the switch on delay during charging of the capacitors. This results in a good low frequency response and good switch on behavior.

### BTL application

Using the SA7347 as a BTL amplifier offers the following advantages:

- Low peak value of the supply current
- Ripple frequency on the supply voltage is twice the signal frequency
- Good low frequency performance
- No expensive DC-blocking capacitor

### Mode selection

By changing properly DC voltage of pin STBY, SA7347 has follow functional modes which can be selected for all channels.

- $0 < \text{STBY} < 0.8\text{V}$ : The current consumption is very low and the outputs are floating.
- $4.5\text{V} < \text{STBY} < V_{CC}/2+2\text{V}$ : The amplifier is DC biased, but no audio output. This allows the input coupling capacitors to be charged to avoid pop-noise.
- $V_{CC}/2+3\text{V} < \text{STBY} < V_{CC}$ : The amplifier is operating normally.

### Supply voltage ripple rejection

The Supply Voltage Ripple Rejection (SVRR) is measured with an electrolytic capacitor of  $150\mu\text{F}$  on pin SVR. A larger capacitor value on pin SVR improves the ripple rejection behavior at the lower frequencies.

### Built-in protection circuits

As mentioned above, SA7347 has a protection circuit based on multiple temperature measurements: one measures local temperature of the power stages and another measure the global chip temperature. This

protection circuit will start to switch off the bias of channel when local temperature reaches approximately 185°C or global temperature reaches approximately 150°C. As a result, there is low dissipating in the chip. It starts operating again when the chip temperature drop to same value below the die temperature. But if the temperature again begins to rise, the SA7347 shuts down again. The process will not stop until the local temperature is under 185°C and the global temperature is under 150°C.

This protects the SA7347 against shorts to ground, to the supply voltage and across the load, and against too high chip temperatures. However, not that there are abnormal events as shorts to ground, to the supply voltage and across the load in the chip, the protection circuit should start-up. In fact, just as much as the temperature does not exceed the critical level, the protection circuit will not operate.

### Power Dissipation and Heat Sinking

Proper heat sinking is necessary to ensure that SA7347 will function correctly under all operating conditions. A heat sink that is too small will cause the die to heat excessively and will result in a degraded output signal as the thermal protection circuitry begins to operate.

In order to determine the appropriate heat sink for a given application, the power dissipation of the SA7347 in that application must be known. When the load is resistive, the maximum average power that the IC will be required to dissipate is approximately:

$$P_{D(MAX)}=4*VS^2/(2\pi^2RL)+PQ$$

Where VS is the total power supply voltage across the SA7347, RL is the load resistance; PQ is the quiescent power dissipation of the amplifier. The above equation is only an approximation which assumes an "ideal" class B output stage and constant power dissipation in all other parts of the circuit. As an example, if the SA7347 is operated on a 15V power supply with a resistive load of 4Ω, it can develop up to 13.5W of internal power dissipation. If the die temperature is to remain below 150°C for ambient temperatures up to 60°C, the total junction-to-ambient thermal resistance must be less than:

$$(150^{\circ}\text{C}-60^{\circ}\text{C})/13.5\text{W}=6.7^{\circ}\text{C}/\text{W}$$

Using  $R_{th(j-c)} = 1.3^{\circ}\text{C}/\text{W}$ , the sum of the case-to-heat-sink interface thermal resistance and the heat-sink-to-ambient thermal resistance must be less than 5.4°C/W. The case-to-heat-sink thermal resistance of the HSIP-15 package varies with the mounting method used. A metal-to-metal interface will be about 1°C/W if lubricated, and about 1.5°C/W if dry.

$$6.7^{\circ}\text{C}/\text{W}-1.3^{\circ}\text{C}/\text{W}-1^{\circ}\text{C}/\text{W}=4.4^{\circ}\text{C}/\text{W}$$

The thermal requirements can become more difficult when an amplifier is driving a reactive load. For a given magnitude of load impedance, a higher degree of reactance will cause a higher level of power dissipation within the amplifier. As a general rule, the power dissipation of an amplifier driving a 60° reactive load (usually considered to be a worst-case loudspeaker load) will be roughly that of the same amplifier driving the resistive part of that load. For example, a loudspeaker may at some frequency have an impedance with a magnitude of 8Ω and a phase angle of 60°. The real part of this load will then be 4Ω, and the amplifier power dissipation will roughly follow the curve of power dissipation with a 4Ω load.

TYPICAL APPLICATION CIRCUIT

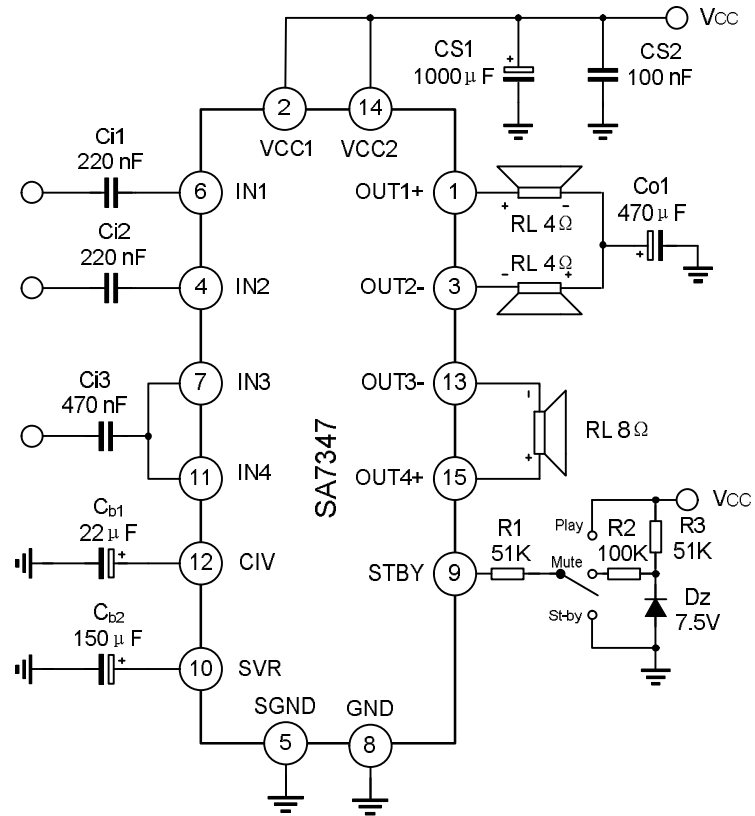

PC BOARD AND COMPONENTS LAYOUT OF TYPICAL APPLICATION CIRCUIT

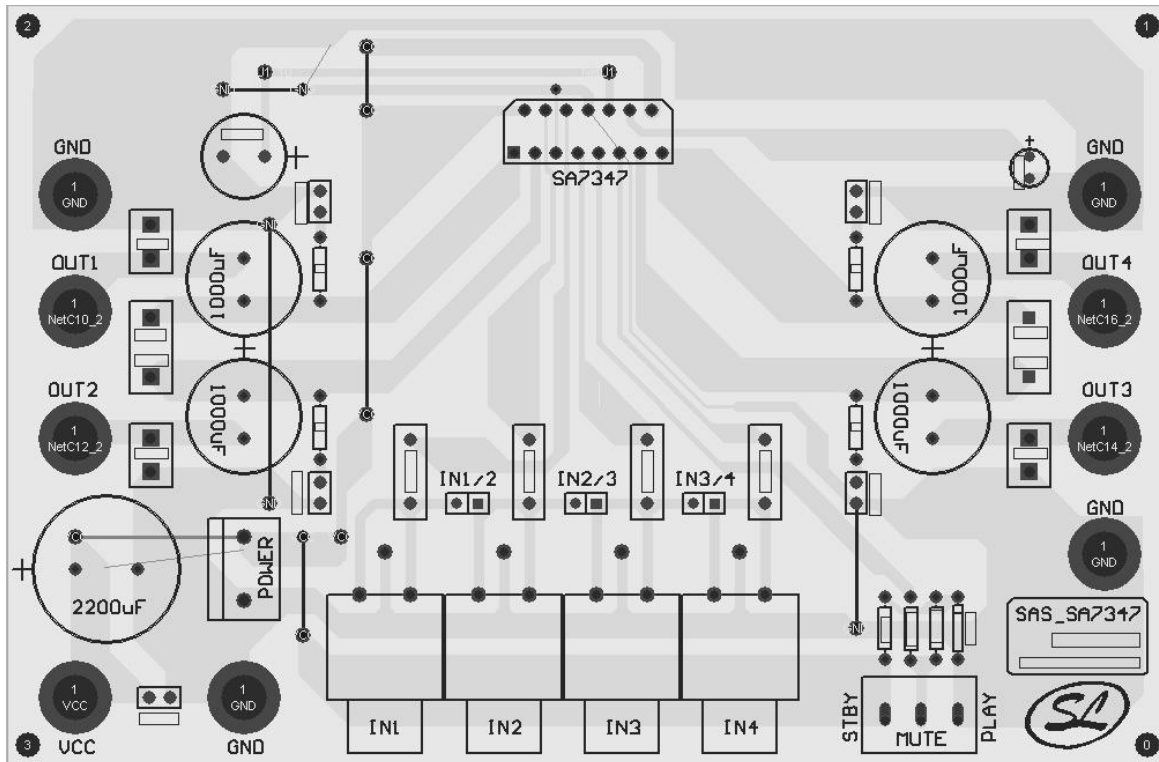

RECOMMENDED APPLICATION VALUE OF DEVICE

Next table shows the recommended value corresponding to the components in the typical application circuit.

COMPONENTS	RECOMMENDED VALUE	PURPOSE
CS1	1000µF	Supply voltage filtering and bypassing
CS2	100nF	
Cb1	22µF	Common input voltage decoupling
Cb2	150µF	Half supply voltage decoupling
Ci1	220nF	Input AC coupling capacitor(SE)
Ci2		
Ci3	470nF	Input AC coupling capacitor(BTL)
CO1	470µF	Output AC coupling capacitor
R1	51KΩ	STBY controller
R2	100KΩ	
R3	51KΩ	
Dz	7.5V	

PACKAGE OUTLINE

HSIP-15

UNIT: mm

