

### SWITCHING TYPE POWER SUPPLY APPLICATIONS.

#### FEATURES

- Low Profile Surface Mount Package.
- Low Power Loss, High Efficiency.
- For Use in Low Voltage, High Frequency inverters, Free Wheeling, and Polarity Protection Applications.

#### APPLICATION

- Switching Power Supply.
- DC/DC Converter.
- Home Appliances, Office Equipment.
- Telecommunication.

#### MAXIMUM RATING (Ta=25 °C)

CHARACTERISTIC	SYMBOL	RATING	UNIT
Maximum Repetitive Peak Reverse Voltage	$V_{RRM}$	40	V
Average Output Rectified Current	$I_O$	3	A
Peak One Cycle Surge Forward Current (Non-Repetitive 60Hz)	$I_{FS}$	100	A
Junction Temperature		-40 ~ 125	°C
Storage Temperature Range	$T_{stg}$	-40 ~ 125	°C

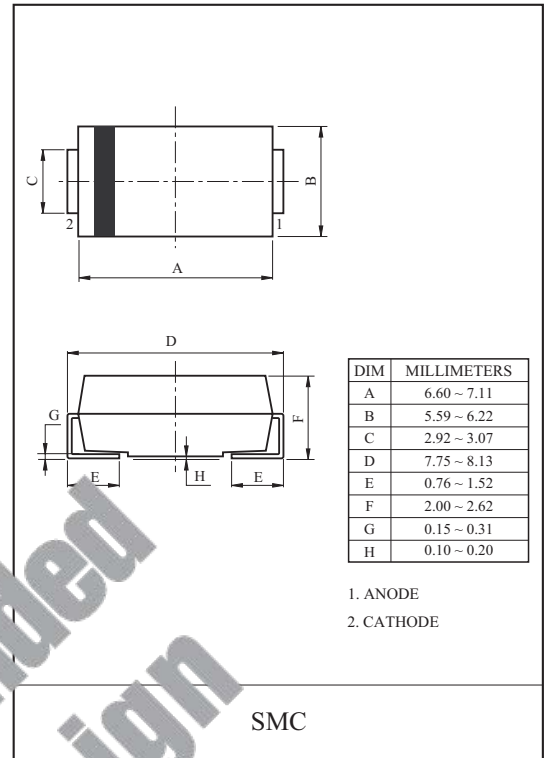

#### Marking

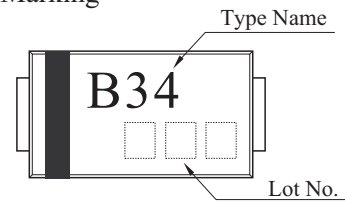

#### ELECTRICAL CHARACTERISTICS (Ta=25 °C)

CHARACTERISTIC	SYMBOL	TEST CONDITION	MIN.	TYP.	MAX.	UNIT
Peak Forward Voltage	$V_{FM}$	$I_{FM}=3A$	-	-	0.5	V
Repetitive Peak Reverse Current	$I_{RRM}$	$V_{RRM}=\text{Rated}, T_a=25$	-	-	0.5	mA
Total Capacitance	$C_T$	$V_R=4V, f=1MHz$	-	-	250	pF
Thermal Resistance	$R_{th(j-l)}$	Junction to lead	-	-	10	/W
	$R_{th(j-a)}$	Junction to ambient	-	-	50	/W

# SMCB34

$T_I - I_F$

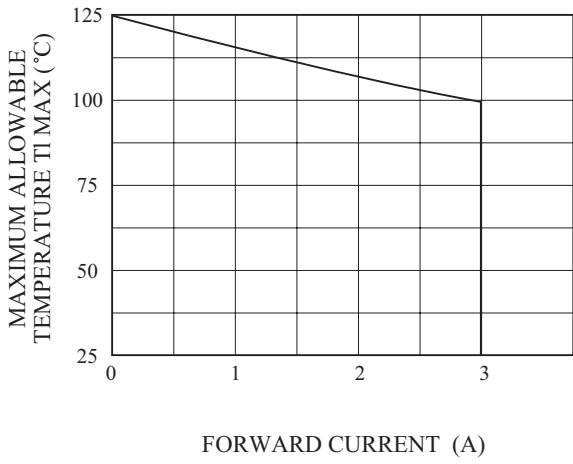

SURGE FORWARD CURRENT (NON - REPETITIVE)

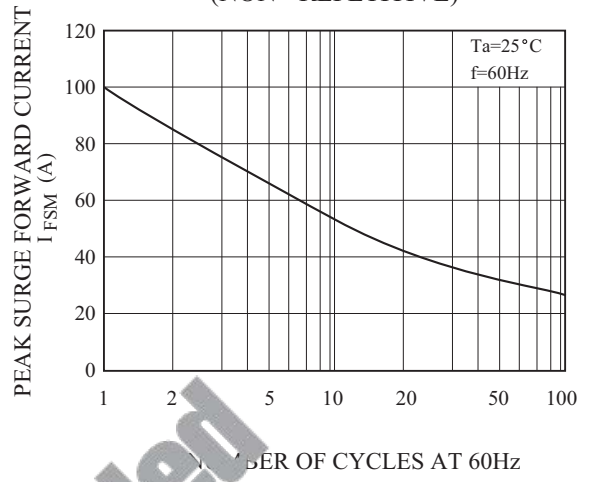

$I_F - V_F$

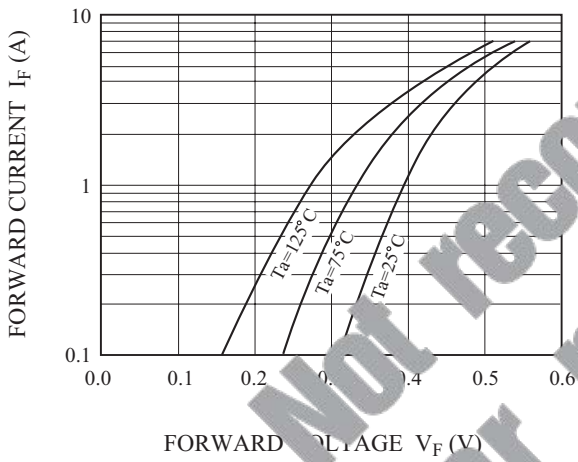

$I_R - V_R$

