

## Digital transistors (built-in resistors)

### PNP Silicon Surface Mount Transistor with Monolithic Bias Resistor Network

• **Applications**

Inverter, Interface, Driver

• **Features**

1) Built-in bias resistors enable the configuration of an inverter circuit without connecting external input resistors (see equivalent circuit).

2) The bias resistors consist of thin-film resistors with complete isolation to allow positive biasing of the input. They also have the advantage of almost completely eliminating parasitic effects.

3) Only the on/off conditions need to be set for operation, making the device design easy.

- We declare that the material of product compliance with RoHS requirements.

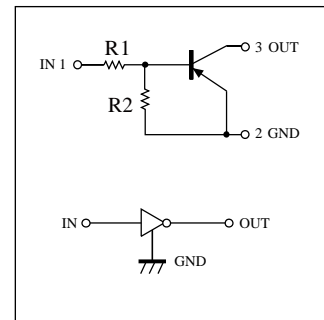
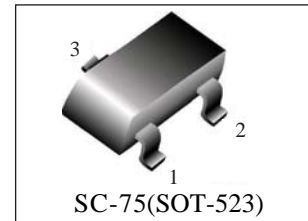

● **Absolute maximum ratings** (Ta= 25°C)

Parameter	Symbol	Limits	Unit
Supply voltage	V <sub>cc</sub>	-50	V
Input voltage	V <sub>i</sub>	-30 to +5	V
Output current	I <sub>o</sub>	-100	mA
	I <sub>c(Max.)</sub>	-100	
Power dissipation	P <sub>d</sub>	200	mW
Junction temperature	T <sub>j</sub>	150	°C
Storage temperature	T <sub>stg</sub>	-55 to +150	°C

**DEVICE MARKING AND RESISTOR VALUES**

Device	Marking	R1 (K)	R2 (K)	Shipping
DTA606E	37	4.7	47	3000/Tape & Reel

● **Electrical characteristics** (Ta=25°C)

Parameter	Symbol	Min.	Typ.	Max.	Unit	Conditions
Input voltage	V <sub>i(off)</sub>	-	-	-0.5	V	V <sub>cc</sub> =-5V, I <sub>o</sub> =-100μA
	V <sub>i(on)</sub>	-1.3	-	-		V <sub>o</sub> =-0.3V, I <sub>o</sub> =-5mA
Output voltage	V <sub>o(on)</sub>	-	-0.1	-0.3	V	I <sub>o</sub> /I <sub>i</sub> =-5mA/-0.25mA
Input current	I <sub>i</sub>	-	-	-1.8	mA	V <sub>i</sub> =-5V
Output current	I <sub>o(off)</sub>	-	-	-0.5	μA	V <sub>cc</sub> =-50V, V <sub>i</sub> =0V
DC current gain	G <sub>i</sub>	80	-	-	-	V <sub>o</sub> =-5V, I <sub>o</sub> =-10mA
Input resistance	R <sub>1</sub>	3.29	4.7	6.11	kΩ	-
Resistance ratio	R <sub>2</sub> /R <sub>1</sub>	8	10	12	-	-
Transition frequency	f <sub>t</sub> *	-	250	-	MHz	V <sub>CE</sub> =-10V, I <sub>E</sub> =5mA, f=100MHz

\* Characteristics of built-in transistor

## ●Electrical characteristic curves

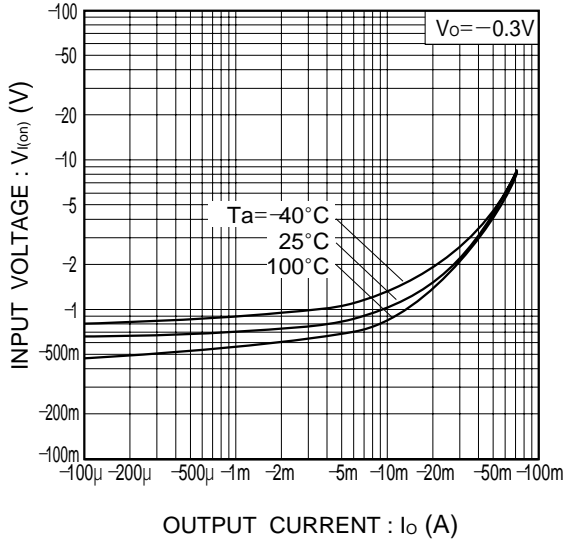

Fig.1 Input voltage vs. output current (ON characteristics)

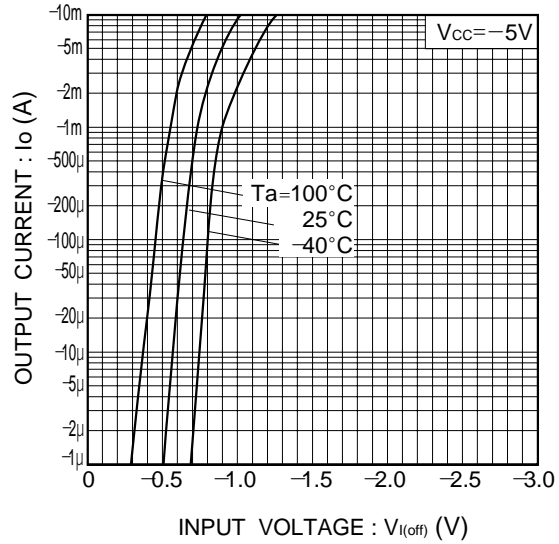

Fig.2 Output current vs. input voltage (OFF characteristics)

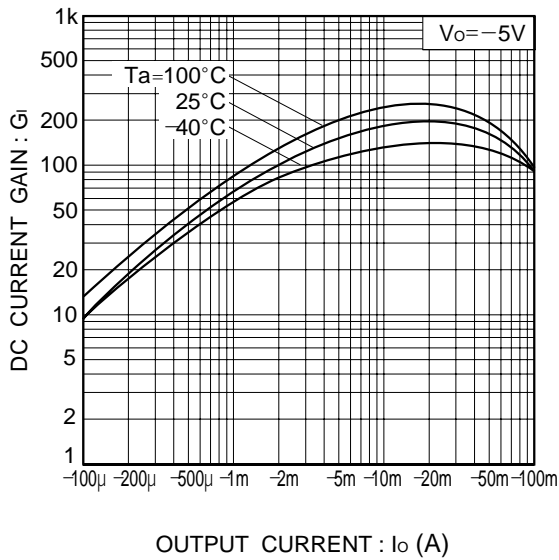

Fig.3 DC current gain vs. output current

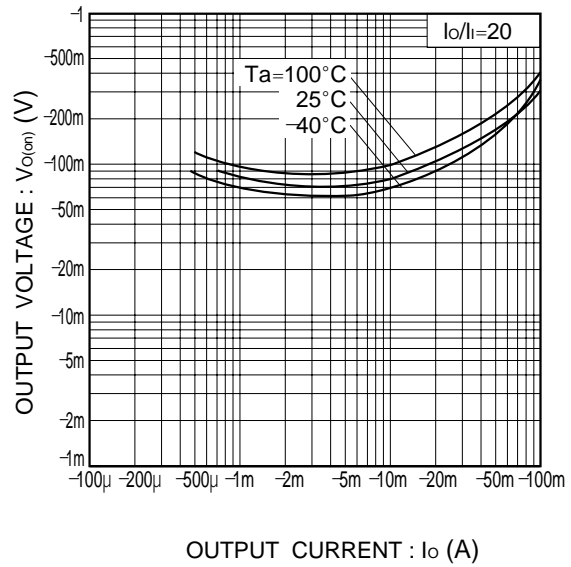
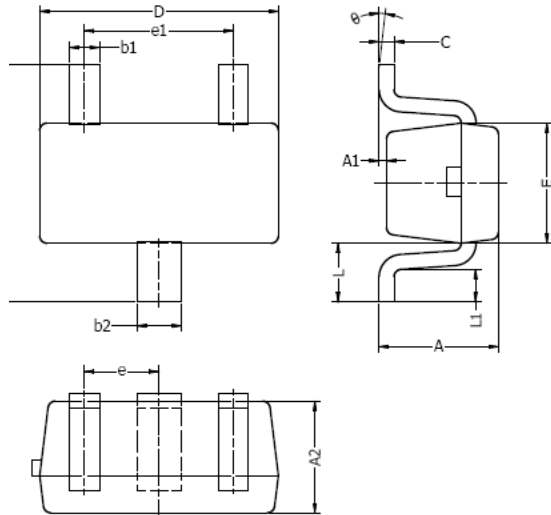

Fig.4 Output voltage vs. output current

## SOT-523(SC-75) OUTLINE AND DIMENSIONS



DIM	MILLIMETERS		INCHES	
	MIN	MAX	MIN	MAX
A	0.70	0.90	0.028	0.035
A1	0.00	0.10	0.000	0.004
A2	0.70	0.80	0.028	0.031
b1	0.15	0.25	0.006	0.010
b2	0.25	0.35	0.010	0.014
c	0.10	0.20	0.004	0.008
D	1.50	1.70	0.059	0.067
E	0.70	0.90	0.028	0.035
E1	1.45	1.75	0.057	0.069
e	0.50 TYP.		0.020 TYP.	
e1	0.90	1.10	0.035	0.043
L	0.40 REF.		0.016 REF.	
L1	0.10	0.30	0.004	0.012
$\theta$	0°	8°	0°	8°

### Typical Soldering Pattern:

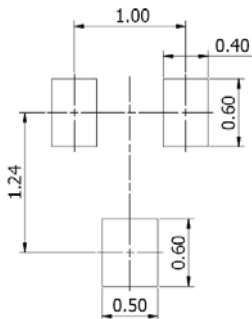

### NOTES:

1. Above package outline conforms to JEITA EAIJ ED-7500A SC-75.
2. Dimensions are exclusive of Burrs, Mold Flash & Tie Bar extrusions.