



U74LVC240

CMOS IC

OCTAL BUFFER/DRIVER WITH 3-STATE OUTPUTS

DESCRIPTION

The **U74LVC240** contains two 4-bit line drivers with separate output-enable(\overline{OE}) inputs. When \overline{OE} is low, the device passes data from the A to the Y. When \overline{OE} is high, the outputs are in the high-impedance state.

The **U74LVC240** can be used in a mixed 3.3V/5V system environment. This device has power-down protective circuit, preventing device destruction when it is powered down.

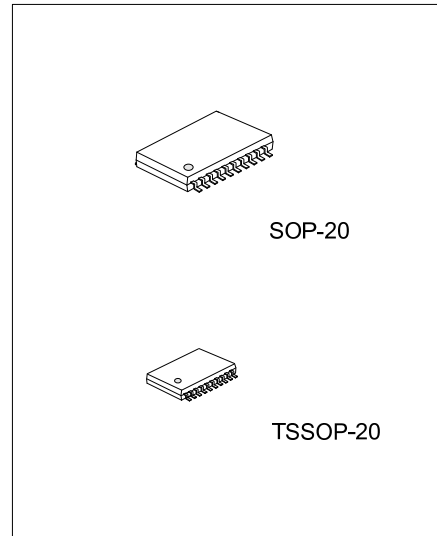

FEATURES

- * Operate From 1.65V to 3.6V
- * Input Accept Voltages to 5.5V
- * Partial-Power-Down Mode Operation
- * Max tpd is 5.9ns at 3.3V

ORDERING INFORMATION

Ordering Number		Package	Packing
Lead Free	Halogen Free		
U74LVC240L-S20-R	U74LVC240G-S20-R	SOP-20	Tape Reel
U74LVC240L-P20-R	U74LVC240G-P20-R	TSSOP-20	Tape Reel

<p>U74LVC240G-P20-T</p>	<p>(1) T: Tube, R: Tape Reel (2) P20: TSSOP-20, S20: SOP-20 (3) G: Halogen Free and Lead Free, L: Lead Free</p>
-------------------------	---

MARKING

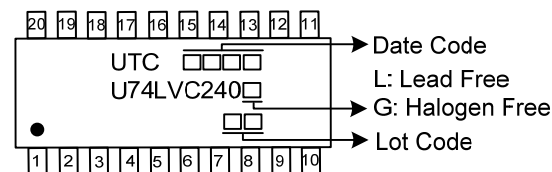

■ PIN CONFIGURATION

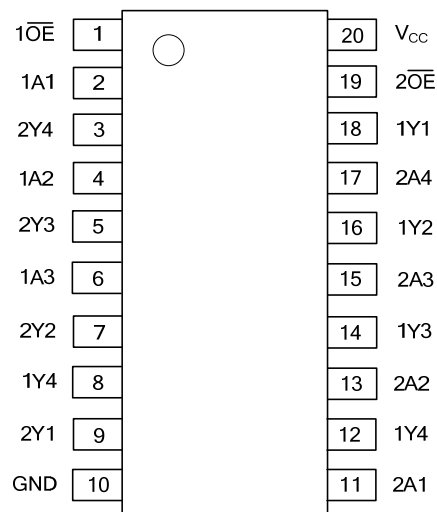

■ FUNCTION TABLE

INPUT		OUTPUT
\overline{OE}	A	Y
H	x	Z
L	H	L
L	L	H

■ LOGIC DIAGRAM (POSITIVE LOGIC)

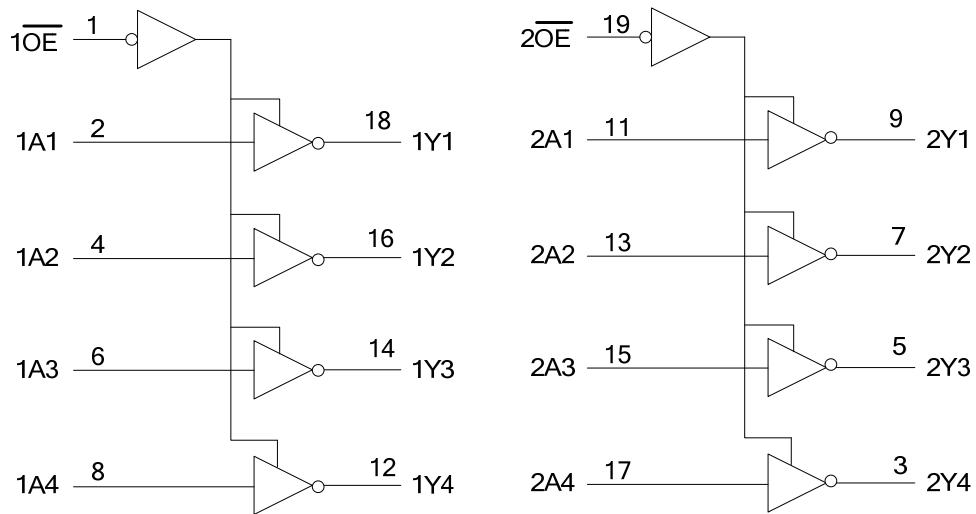

■ LOGIC SYMBOL

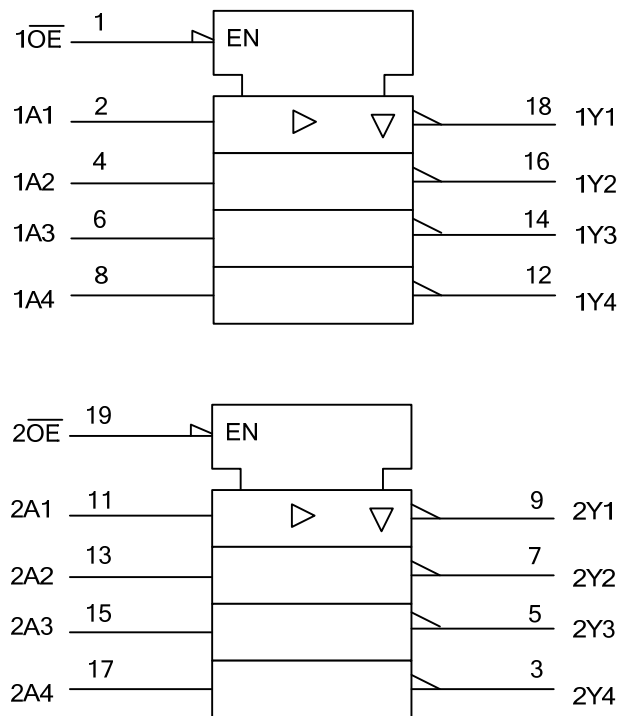

■ ABSOLUTE MAXIMUM RATING ($T_A = 25^\circ\text{C}$, unless otherwise specified)

PARAMETER	SYMBOL	RATINGS	UNIT
Supply Voltage	V_{CC}	-0.5 ~ 6.5	V
Input Voltage	V_{IN}	-0.5 ~ 6.5	V
Voltage applied to output in high-impedance or power-off state	V_{OUT}	-0.5 ~ 6.5	V
Voltage applied to output in high or low state		-0.5 ~ $V_{CC}+0.5$	
Input Clamp Current	I_{IK}	-50	mA
Output Clamp Current	I_{OK}	-50	mA
Output Current	I_{OUT}	± 50	mA
Vcc or GND Current	I_{CC}	± 100	mA
Storage Temperature	T_{STG}	-65 ~ +150	$^\circ\text{C}$

Notes: 1. Absolute maximum ratings are those values beyond which the device could be permanently damaged.

Absolute maximum ratings are stress ratings only and functional device operation is not implied.

2. The input and output voltage ratings may be exceeded if the input and output current ratings are observed.

■ RECOMMENDED OPERATING CONDITIONS ($T_A = 25^\circ\text{C}$, unless otherwise specified)

PARAMETER	SYMBOL	TEST CONDITIONS	MIN	TYP	MAX	UNIT
Supply Voltage	V_{CC}	Operating	1.65		3.6	V
		Data retention only	1.50			V
High-level input voltage	V_{IH}	$V_{CC}=1.65\text{V}\sim 1.95\text{V}$	$0.65 \times V_{CC}$			V
		$V_{CC}=2.3\text{V}\sim 2.7\text{V}$	1.7			V
		$V_{CC}=2.7\text{V}\sim 3.6\text{V}$	2			V
Low-level input voltage	V_{IL}	$V_{CC}=1.65\text{V}\sim 1.95\text{V}$			$0.35 \times V_{CC}$	V
		$V_{CC}=2.3\text{V}\sim 2.7\text{V}$			0.7	V
		$V_{CC}=2.7\text{V}\sim 3.6\text{V}$			0.8	V
Input voltage	V_{IN}		0		5.5	V
Output Voltage	V_{OUT}	High or low state	0		V_{CC}	V
		3state	0		5.5	V
High level output current	I_{OH}	$V_{CC}=1.65\text{V}$			-4	mA
		$V_{CC}=2.3\text{V}$			-8	mA
		$V_{CC}=2.7\text{V}$			-12	mA
		$V_{CC}=3\text{V}$			-24	mA
Low level output current	I_{OL}	$V_{CC}=1.65\text{V}$			4	mA
		$V_{CC}=2.3\text{V}$			8	mA
		$V_{CC}=2.7\text{V}$			12	mA
		$V_{CC}=3\text{V}$			24	mA
Input transition rise or fall rate	$\Delta t/\Delta v$		0		6	ns/V
Operating free-air temperature	T_A		-40		+125	$^\circ\text{C}$

■ ELECTRICAL CHARACTERISTICS (T_A =25°C, unless otherwise specified)

PARAMETER	SYMBOL	TEST CONDITIONS	MIN	TYP (Note 1)	MAX	UNIT
Output Voltage High-Level	V _{OH}	V _{CC} =1.65~3.6V, I _{OH} =-100uA	V _{CC} -0.2			V
		V _{CC} =1.65V, I _{OH} =-4mA	1.2			V
		V _{CC} =2.3V, I _{OH} =-8mA	1.7			V
		V _{CC} =2.7V, I _{OH} =-12mA	2.2			V
		V _{CC} =3.0V, I _{OH} =-12mA	2.4			V
		V _{CC} =3.0V, I _{OH} =-24mA	2.2			V
Output Voltage Low-Level	V _{OL}	V _{CC} =1.65~3.6V, I _{OL} =100uA			0.2	V
		V _{CC} =1.65V, I _{OL} =4mA			0.45	V
		V _{CC} =2.3V, I _{OL} =8mA			0.7	V
		V _{CC} =2.7V, I _{OL} =12mA			0.4	V
		V _{CC} =3.0V, I _{OL} =24mA			0.55	V
Input Leakage Current	I _{I(LEAK)}	V _I =5.5 V or GND, V _{CC} =3.6V			±5	μA
Power off Leakage Current	I _{off}	V _I or V _O =5.5V, V _{CC} =0V			±10	mA
Output OFF-State Current	I _{OZ}	V _O =0 ~ 5.5 V, V _{CC} =3.6V			±10	μA
Quiescent Supply Current (I _O =0)	I _{CC}	V _I =V _{CC} or GND, V _{CC} =3.6V			10	μA
		3.6V ≤ V _I ≤ 5.5V, V _{CC} =3.6V (Note 2)			10	μA
Additional quiescent supply current	ΔI _{CC}	One input at V _{CC} -0.6V, Other inputs at V _{CC} or GND, V _{CC} =2.7~3.6V			500	μA
Input Capacitance	C _{IN}	V _I =V _{CC} or GND, V _{CC} =3.3V		4		pF
Output Capacitance	C _{OUT}	V _O =V _{CC} or GND, V _{CC} =3.3V		5.5		pF

Notes: 1. All typical values are at V_{CC}=3.3V, T_A=25°C.

2. This applies in the disabled state only.

■ SWITCHING CHARACTERISTICS (T_A =25°C, unless otherwise specified)

PARAMETER	SYMBOL	CONDITIONS	MIN	TYP	MAX	UNIT
Propagation Delay Time Signal From input A to output Y	t _{PD}	V _{CC} =2.7V			7.5	ns
		V _{CC} =3.3 V ± 0.3 V	1.3		6.5	ns
Propagation Delay Time Signal From input \overline{OE} to output Y	t _{en}	V _{CC} =2.7V			9	ns
		V _{CC} =3.3 V ± 0.3 V	1.1		8	ns
Propagation Delay Time Signal From input \overline{OE} to output Y	t _{dis}	V _{CC} =2.7V			8	ns
		V _{CC} =3.3 V ± 0.3 V	1.4		7	ns
High-impedance state Current (Note)	t _{sk}	V _{CC} =3.3 V ± 0.3 V			1	ns

Note: Skew between any two outputs of the same package switching in the same direction

■ OPERATING CHARACTERISTICS (T_A =25°C, unless otherwise specified)

PARAMETER	SYMBOL	TEST CONDITIONS	MIN	TYP	MAX	UNIT
Power Dissipation Capacitance	C _{PD}	\overline{OE} =0, f=10MHZ, V _{CC} =3.3V		32		pF
		\overline{OE} =1, f=10MHZ, V _{CC} =3.3V		3		pF

■ TEST CIRCUIT AND WAVEFORMS

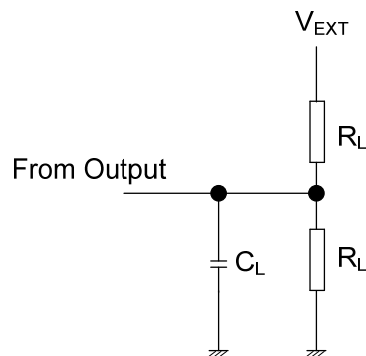

V_{CC}	V_I	t_r/t_f	V_M	V_{Δ}	C_L	R_L	V_{EXT}		
							T_{PLH}/T_{PHL}	T_{PZH}/T_{PHZ}	T_{PZL}/T_{PLZ}
2.7 V	2.7 V	$\leq 2.5\text{ns}$	6V	0.3V	50 pF	500 Ω	OPEN	GND	6 V
3.3V \pm 0.3V	2.7 V	$\leq 2.5\text{ns}$	6V	0.3V	50 pF	500 Ω	OPEN	GND	6 V

Fig-1 Load circuitry

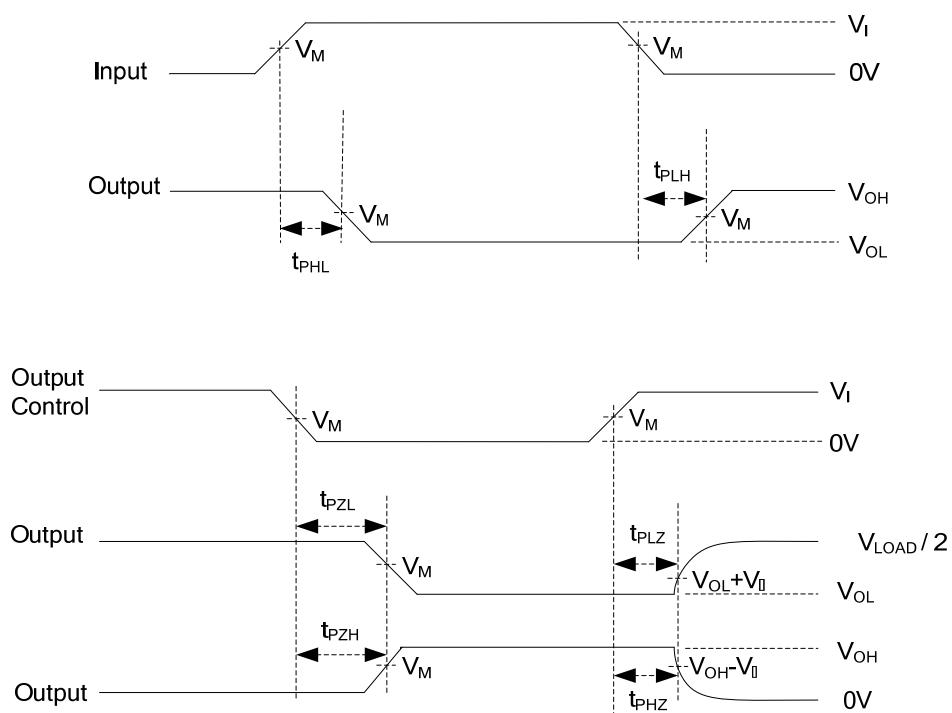

Fig-2 Propagation delay waves

UTC assumes no responsibility for equipment failures that result from using products at values that exceed, even momentarily, rated values (such as maximum ratings, operating condition ranges, or other parameters) listed in products specifications of any and all UTC products described or contained herein. UTC products are not designed for use in life support appliances, devices or systems where malfunction of these products can be reasonably expected to result in personal injury. Reproduction in whole or in part is prohibited without the prior written consent of the copyright owner. UTC reserves the right to make changes to information published in this document, including without limitation specifications and product descriptions, at any time and without notice. This document supersedes and replaces all information supplied prior to the publication hereof.