

Dual Operational Amplifier

LR358/LR2904

General Description

The LR358/LR2904 consists of two independent, high gain and internally frequency compensated operational amplifiers, it is specifically designed to operate from a single power supply. Operation from split power supply is also possible and the low power supply current drain is independent of the magnitude of the power supply voltages.

Features

- Internally Frequency Compensation
- Large Voltage Gain
- Low Input Bias Current
- Low Input Offset Voltage
- Large Output Voltage Swing

Ordering Information

Device	Package
LR358	DIP-8
LR358D	SOP-8
LR2904	DIP-8
LR2904D	SOP-8

Package

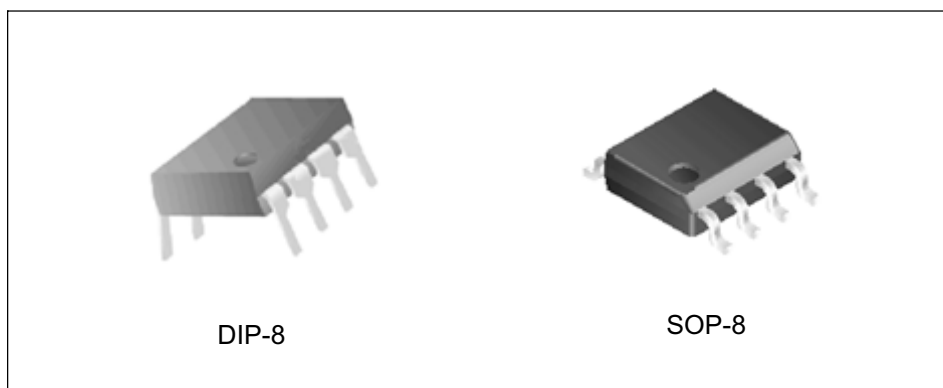

Figure 1. Package Types of LR358/LR2904

Pin Configuration

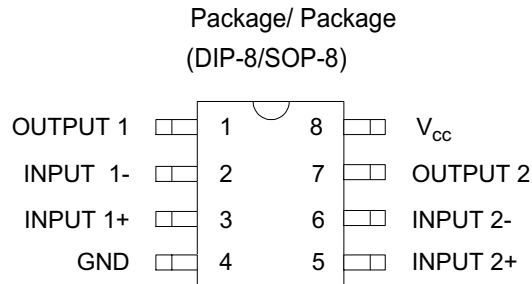

Figure 2. Pin Configuration of LR358/LR2904 (Top View)

Functional Block Diagram

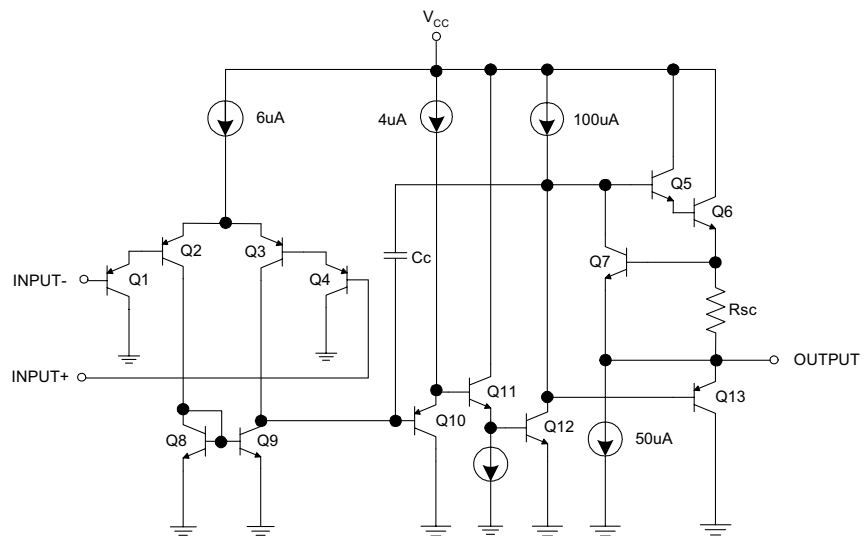

Figure 3. Functional Block Diagram of LR358/LR2904 Each Amplifier)

Absolute Maximum Ratings

Parameter		Value	Unit
Power Supply Voltage		32 ±16	V
Differential Input Voltage		32	V
Input Voltage		-0.3~32	V
Power Dissipation	DIP -8	550	mW
	SOP -8	530	
Output Short-Circuit to Ground ($V^+ \leq 15V$, $T_a = 25^\circ C$)		Continuous	
Input Current ($V_{IN} < -0.3V$)		50	mA
Operating Temperature Range LR358		-25~85	°C
Operating Temperature Range LR2904		-40~125	°C
Storage Temperature Range		-65~150	°C

Electrical Characteristics

Parameter	Test Conditions	Value			Unit	
		Min	Typ	Max		
Input Offset Voltage	$T_a = 25^\circ C$		2	5	mV	
Input Bias Current	$T_a = 25^\circ C$, $I_{IN(+)} I_{IN(-)}$, $V_{CM} = 0V$		45	150	nA	
Input Offset Current	$T_a = 25^\circ C$, $I_{IN(+)} - I_{IN(-)}$, $V_{CM} = 0V$		3	30	nA	
Supply Current	$V^+ = 30V$		1	2	mA	
	$V^+ = 5V$		0.5	1.2		
Large Signal Voltage Gain	$V^+ = 15V$, $T_a = 25^\circ C$, $R_L \geq 2k\Omega$	50	100		V/mV	
Common Mode Rejection Ratio	DC, $T_a = 25^\circ C$, $V_{CM} = 0 \sim V^+ - 1.5V$	70	85		dB	
Power Supply Rejection Ration	DC, $T_a = 25^\circ C$, $V^+ = 5 \sim 30V$	65	100		dB	
Output Current (Source)	$V_{IN(+)} = 1V, V_{IN(-)} = 0V, V^+ = 15V, V_o = 2V, T_a = 25^\circ C$	20	40		mA	
Output Current (Sink)	$V_{IN(-)} = 1V, V_{IN(+)} = 0V, V^+ = 15V, V_o = 2V, T_a = 25^\circ C$	10	20		mA	
	$V_{IN(-)} = 1V, V_{IN(+)} = 0V, V^+ = 15V, V_o = 2V$	5	8		mA	
Short Circuit to Ground	$V^+ = 15V, T_a = 25^\circ C$		40	60	mA	
Output Voltage Swing	V_{OH}	$V^+ = 30V$	$R_L = 2k\Omega$	26		V
			$R_L = 10k\Omega$	27	28	V
	V_{OL}	$V^+ = 5V, R_L = 10k\Omega$		5	20	mV

Typical Performance Characteristics

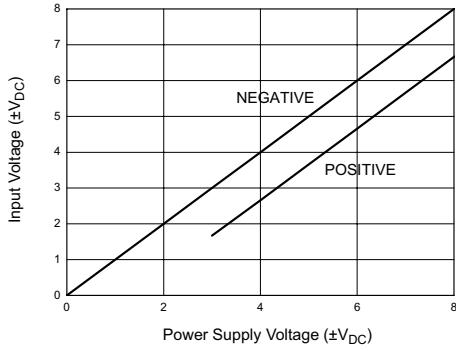

Figure 4. Input Voltage Range

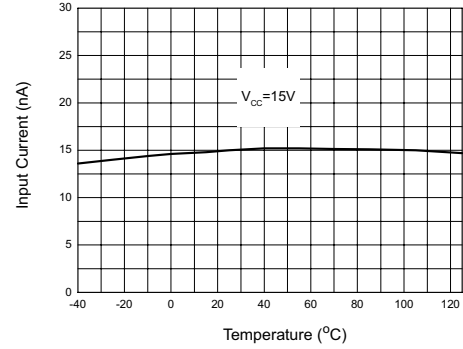

Figure 5. Input Current

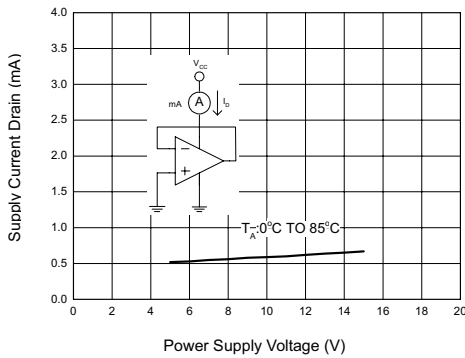

Figure 6. Supply Current

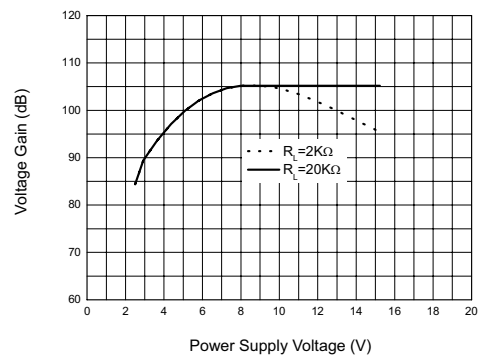

Figure 7. Voltage Gain

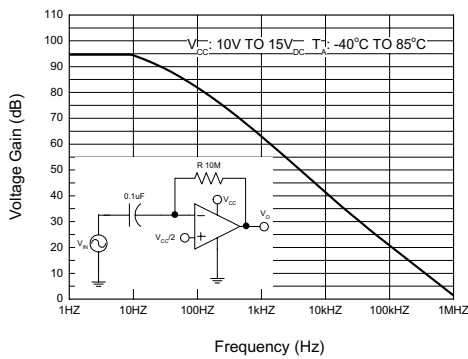

Figure 8. Open Loop Frequency Response

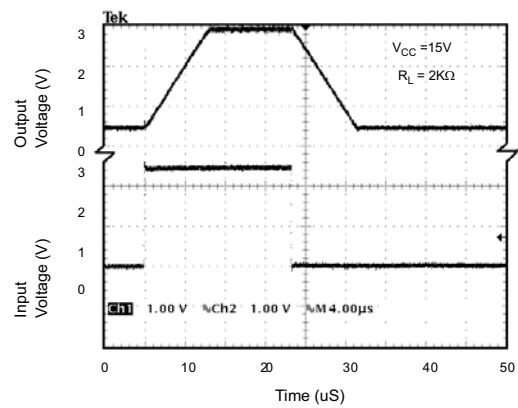

Figure 9. Voltage Follower Pulse Response

Typical Performance Characteristics (Continued)

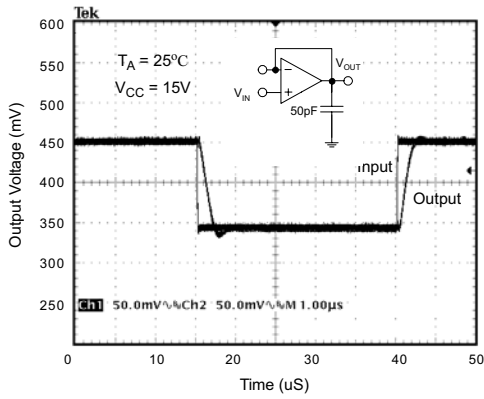

Figure 10. Voltage Follower Pulse Response (Small Signal)

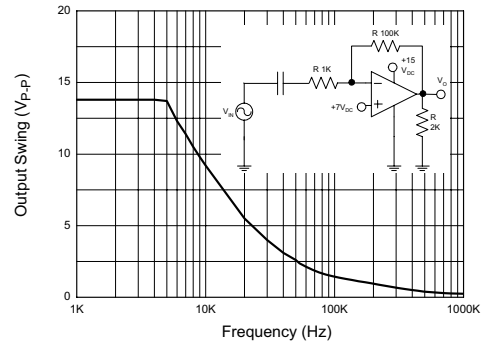

Figure 11. Large Signal Frequency Response

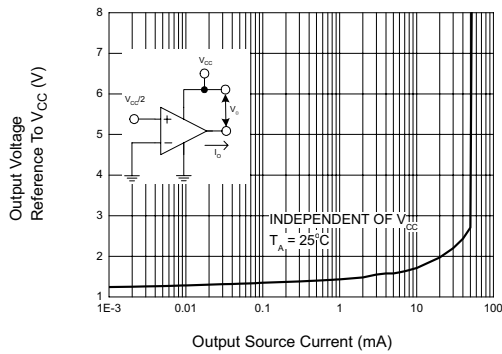

Figure 12. Output Characteristics Current Sourcing

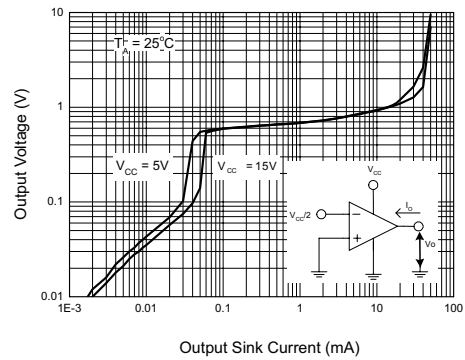

Figure 13. Output Characteristics Current Sinking

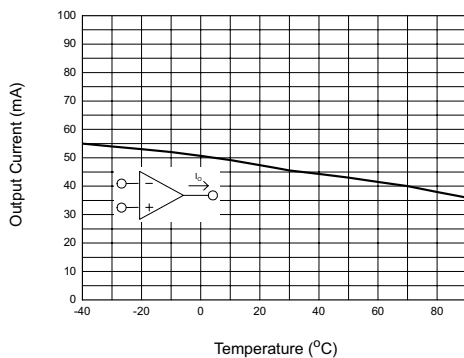

Figure 14. Current Limiting

Typical Application (Continued)

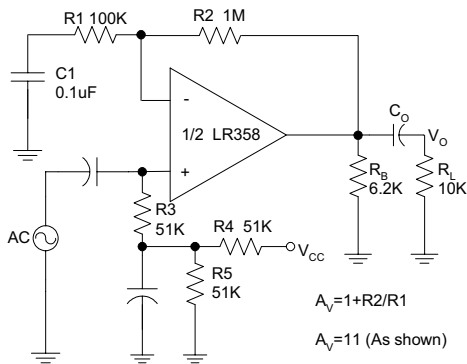

Figure 18. AC Coupled Non-Inverting Amplifier

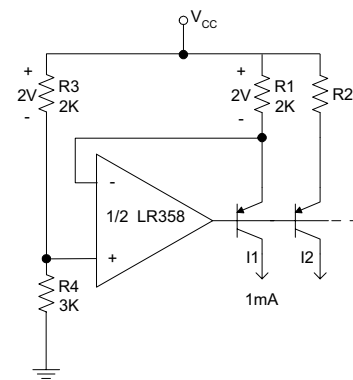

Figure 19. Fixed Current Sources

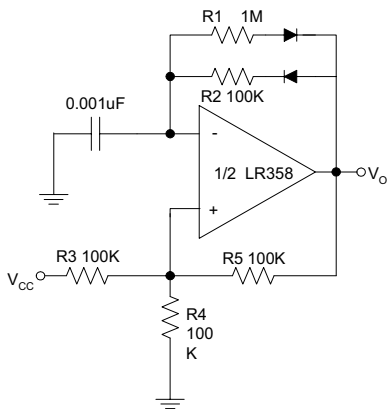

Figure 20. Pulse Generator

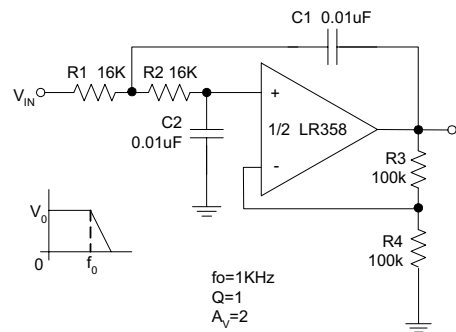
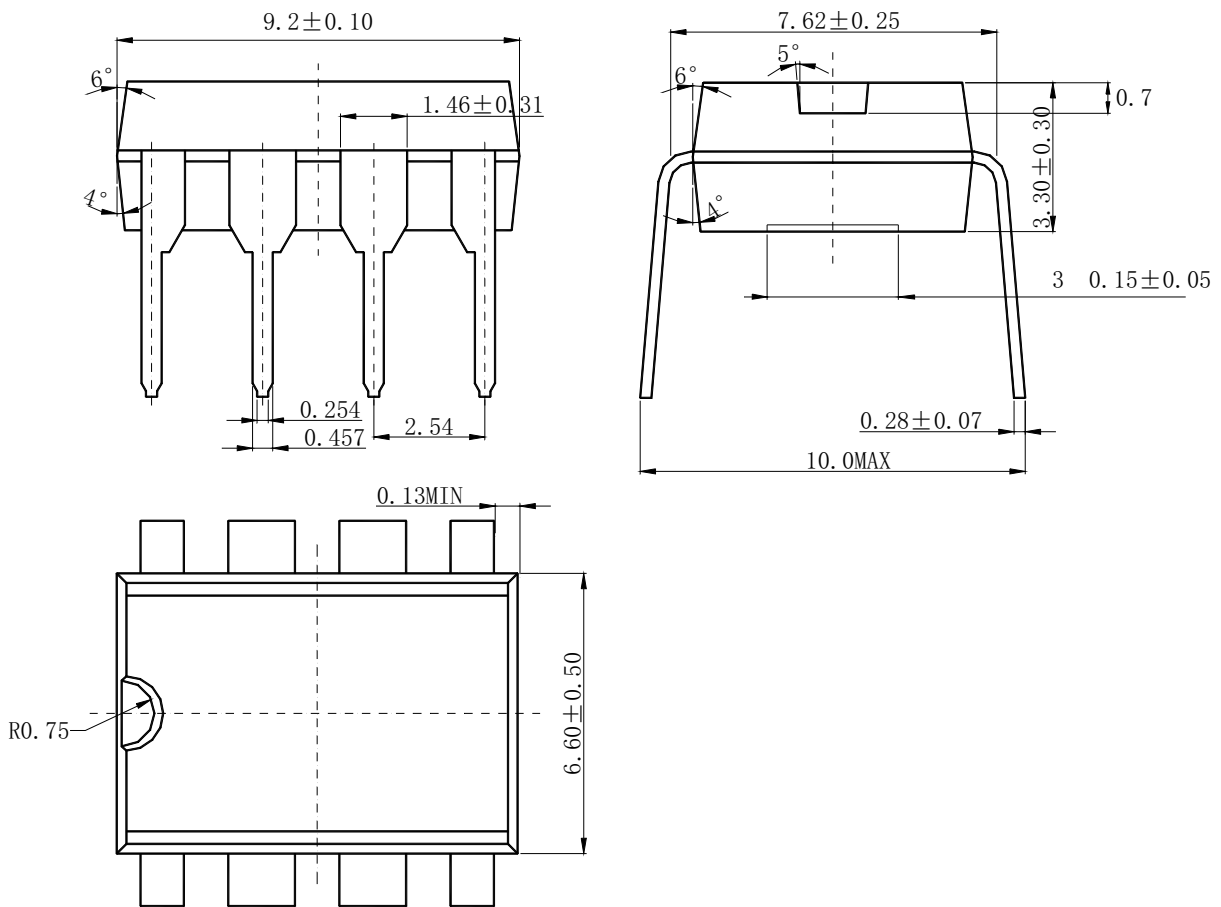

Figure 21. DC Coupled Low-Pass Active Filter

Mechanical Dimensions

DIP-8

Unit: mm



Mechanical Dimensions (Continued)

SOP-8

Unit: mm

