



Precision, Dual, High-Speed Analog Switches

MAX301/MAX303/MAX305

General Description

The MAX301/MAX303/MAX305 are precision, dual, high-speed analog switches. The single-pole single-throw (SPST) MAX301 and double-pole single-throw (DPST) MAX305 dualswitches are normally open (NO). The single-pole double-throw (SPDT) MAX303 has two NO and two normally closed (NC) poles. All three parts offer low on resistance (less than 35Ω), guaranteed to match to within 2Ω between channels and to remain flat over the full analog signal range ($\Delta 3_{max}$). They also offer low leakage (less than 250pA at +25°C and less than 6nA at +85°C) and fast switching (turn-on time less than 150ns and turn-off time less than 100ns).

The MAX301/MAX303/MAX305 are fabricated with Maxim's new improved silicon-gate process for high system accuracy. Design improvements guarantee extremely low charge injection (15pC) and low power consumption (35μW). A 44V maximum breakdown voltage allows rail-to-rail analog signal capability.

These monolithic switches operate with a single positive supply (+10V to +30V) or with split supplies ($\pm 4.5V$ to $\pm 20V$) while retaining CMOS-logic input compatibility and fast switching. CMOS inputs provide reduced input loading.

Applications

- Sample-and-Hold Circuits Military Radios
- Test Equipment Communication Systems
- Heads-Up Displays Battery-Operated Systems
- Guidance and Control PBX, PABX
- Systems

Features

- ◆ Low On-Resistance < 22Ω Typical (35Ω Max)
- ◆ Guaranteed Matched On-Resistance Between Channels < 2Ω
- ◆ Guaranteed Flat On-Resistance over Full Analog Signal Range $\Delta 3_{\Omega}$ Max
- ◆ Guaranteed Charge Injection < 15pC
- ◆ Guaranteed Off-Channel Leakage < 6nA at +85°C
- ◆ Single-Supply Operation (+10V to +30V)
Bipolar-Supply Operation ($\pm 4.5V$ to $\pm 20V$)
- ◆ TTL-/CMOS-Logic Compatible
- ◆ Rail-to-Rail Analog Signal Handling Capability

Ordering Information

PART	TEMP RANGE	PIN-PACKAGE	PKG CODE
MAX301CPE	0°C to +70°C	16 Plastic DIP	P16-1
MAX301CSE	0°C to +70°C	16 Narrow SO	S16-2
MAX301CJE	0°C to +70°C	16 CERDIP	J16-3
MAX301C/D	0°C to +70°C	Dice*	—
MAX301EPE	-40°C to +85°C	16 Plastic DIP	P16-1
MAX301ESE	-40°C to +85°C	16 Narrow SO	S16-2
MAX301EJE	-40°C to +85°C	16 CERDIP	J16-3
MAX301MJE	-55°C to +125°C	16 CERDIP**	J16-3
MAX301MLP	-55°C to +125°C	20LCC*	L20-3

Ordering Information continued on last page.

*Contact factory for dice specifications.

**Contact factory for package availability.

Pin Configurations/Block Diagrams/Truth Tables

TOP VIEW

MAX301

DIP/SO	
LOGIC	SWITCH
0	OFF
1	ON

LCC packages on last page.

MAX303

DIP/SO			
LOGIC	SWITCHES 1, 2	SWITCHES 3, 4	
0	OFF	ON	
1	ON	OFF	

SWITCHES SHOWN FOR LOGIC "0" INPUT

MAX305

DIP/SO	
LOGIC	SWITCH
0	OFF
1	ON



For pricing, delivery, and ordering information, please contact Maxim Direct at 1-888-629-4642, or visit Maxim's website at www.maxim-ic.com.

Precision, Dual, High-Speed Analog Switches

ABSOLUTE MAXIMUM RATINGS

Voltage Referenced to V-

V+	44V
GND	25V
V _L	(GND-0.3V) to (V+) +0.3V
NO ₋ , NC ₋ , IN ₋ , COM ₋	(V- - 2V) to (V+ + 2V) or 30mA,whichever occurs first
Continuous Current, COM ₋ , NO ₋ , NC ₋	30mA
Peak Current, COM ₋ , NO ₋ , NC ₋ (pulsed at 1ms, 10% duty cycle max)	100mA

Continuous Power Dissipation (T_A = +70°C) (Note 2)

16-Pin Plastic DIP (derate 10.53mW/°C above +70°C)	842mW
16-Pin Narrow SO (derate 8.70mW/°C above +70°C)	696mW
16-Pin CERDIP (derate 10.00mW/°C above +70°C)	800mW
20-Pin LCC (derate 9.09mW/°C above +70°C)	727mW

Operating Temperature Ranges:

MAX30_C_	0°C to +70°C
MAX30_E_	-40°C to +85°C
MAX30_M_	-55°C to +125°C

Storage Temperature Range

Lead Temperature (soldering, 10s)	+300°C
---	--------

Note 1: Signals on NO₋, NC₋, or COM₋ beyond V+ or V- are clamped by internal diodes. Limit forward current to maximum current rating. Stresses beyond those listed under "Absolute Maximum Ratings" may cause permanent damage to the device. These are stress ratings only, and functional operation of the device at these or any other conditions beyond those indicated in the operational sections of the specifications is not implied. Exposure to absolute maximum rating conditions for extended periods may affect device reliability.

ELECTRICAL CHARACTERISTICS

(V+ = 15V, V- = -15V, V_L = +5V, GND = 0V, V_{INH} = +2.4V, V_{INL} = +0.8V, T_A = T_{MIN} to T_{MAX}, unless otherwise noted.)

PARAMETER	SYMBOL	CONDITIONS	TEMP RANGE	MIN	TYP (Note 2)	MAX	UNITS	
SWITCH								
Analog-Signal Range	V _{ANA}	(Note 3)		V-		V+	V	
On-Resistance	R _{ON}	I _(NC or NO) = -10mA, V _{COM-} = ±10V V _{INH} = 2.4V, V _{INL} = 0.8V	T _A = +25°C	C, E	20	35	Ω	
			T _A = T _{MIN} to T _{MAX}	C, E		55		
				M		45		
				M				
On-Resistance Match Between Channels (Note 4)	R _{ON}	I _(NC or NO) = -10mA, V _{COM-} = ±10V V+ = 15V, V- = -15V	T _A = +25°C	C, E, M	0.5	2	Ω	
			T _A = T _{MIN} to T _{MAX}	C, E, M		3		
On-Resistance Flatness (Note 4)	R _{ON}	I _S = -10mA V _{COM-} = ±5V V+ = 15V, V- = -15V	T _A = +25°C	C, E, M		3	Ω	
			T _A = T _{MIN} to T _{MAX}	C, E, M		5		
NC or NO Off-Leakage Current	NC _(OFF) or NO _(OFF)	V _{COM-} = ±15.5V, V _{NC-} or V _{NO-} = ±15.5V, V+ = 16.5V, V- = -16.5V	T _A = +25°C	C, E	-0.50	-0.01	0.50	nA
			T _A = T _{MIN} to T _{MAX}	M	-0.25	-0.01	0.25	
				C, E	-6		6	
				M	-20		20	
COM Off-Leakage Current	COM _{OFF}	V _{COM-} = ±15.5V, V _{NC-} or V _{NO-} = ±15.5V, V+ = 16.5V, V- = -16.5V	T _A = +25°C	C, E	-0.50	-0.01	0.50	nA
			T _A = T _{MIN} to T _{MAX}	M	-0.25	-0.01	0.25	
				C, E	-6		6	
				M	-20		20	
COM On-Leakage Current	COM _{ON}	V _{COM-} = ±15.5V, V _{NC-} or V _{NO-} = ±15.5V, V+ = 16.5V, V- = -16.5V	T _A = +25°C	C, E	-1.0	-0.04	1.0	nA
			T _A = T _{MIN} to T _{MAX}	M	-0.4	-0.04	0.4	
				C, E	-20		20	
				M	-40.0		40.0	

Precision, Dual, High-Speed Analog Switches

MAX301/MAX303/MAX305

ELECTRICAL CHARACTERISTICS (continued)

(V+ = 15V, V- = -15V, VL = +5V, GND = 0V, VINH = +2.4V, VINL = +0.8V, TA = TMIN to TMAX, unless otherwise noted.)

PARAMETER	SYMBOL	CONDITIONS	MIN	TYP (Note 2)	MAX	UNITS	
INPUT							
Input Current with Input-Voltage High	I _{INH}	V _{INL} = 2.4V, all others = 0.8V	-1.000	0.005	1.000	μA	
Input Current with Input-Voltage Low	I _{INH}	V _{INL} = 0.8V, all others = 2.4V	-1.000	0.005	1.000	μA	
SUPPLY							
Power-Supply Range			±4.5		±20	V	
Positive Supply Current	I+	All channels on or off, V _{IN} = 0V or 5V, V+ = 16.5V, V- = -16.5V	T _A = +25°C	-1.00	0.01	1.00	μA
			T _A = T _{MIN} to T _{MAX}	-5.00		5.00	
Negative Supply Current	I-	All channels on or off, V _{IN} = 0V or 5V, V+ = 16.5V, V- = -16.5V	T _A = +25°C	-1.00	-0.01	1.00	μA
			T _A = T _{MIN} to T _{MAX}	-5.00		5.00	
Logic-Supply Current	I _L	All channels on or off, V _{IN} = 0V or 5V, V+ = 16.5V, V- = -16.5V	T _A = +25°C	-1.00	0.01	1.00	μA
			T _A = T _{MIN} to T _{MAX}	-5.00		5.00	
Ground Current	I _{GND}	All channels on or off, V _{IN} = 0V or 5V, V+ = 16.5V, V- = -16.5V	T _A = +25°C	-1.00	-0.01	1.00	μA
			T _A = T _{MIN} to T _{MAX}	-5.00		5.00	
DYNAMIC							
Turn-On Time	t _{ON}	Figure 1			100 150	ns	
Turn-Off Time	t _{OFF}	Figure 1			60 100	ns	
Break-Before-Make Time Delay (Note 3)	t _D	MAX303 only, Figure 2			10 20	ns	
Charge Injection (Note 3)	Q	C _L = 10nF, V _{GEN} = 0V, R _{GEN} = 0Ω, Figure 3			10 15	pC	
Off-Isolation (Note 5)	OIRR	R _L = 100Ω, C _L = 5pF, f = 1MHz, Figure 4			72	dB	
Crosstalk (Note 6)		R _L = 50Ω, C _L = 5pF, f = 1MHz, Figure 5			90	dB	
Off-Capacitance	C _{OF}	f = 1MHz, Figure 6			12	pF	
COM Off-Capacitance	C _{COM(OFF)}	f = 1MHz, Figure 6			12	pF	
Channel-On Capacitance	C _{COM(ON)}	f = 1MHz, Figure 7			39	pF	

Note 2: The algebraic convention, where the most negative value is a minimum and the most positive value a maximum, is used on this data sheet.

Note 3: Guaranteed by design.

Note 4: $\Delta R_{ON} = \Delta R_{ONMAX} - \Delta R_{ONMIN}$. On resistance match between channels and flatness are guaranteed only with specified voltages.

Note 5: See Figure 4. Off isolation = $20 \log_{10} V_{COM}/V_{NC}$ or V_{NO} . V_{COM} = output, V_{NC} or V_{NO} = input to off switch.

Note 6: Between any two switches. See Figure 5.

Precision, Dual, High-Speed Analog Switches

MAX301/MAX303/MAX305

Typical Operating Characteristics

($T_A = +25^\circ\text{C}$, unless otherwise noted).

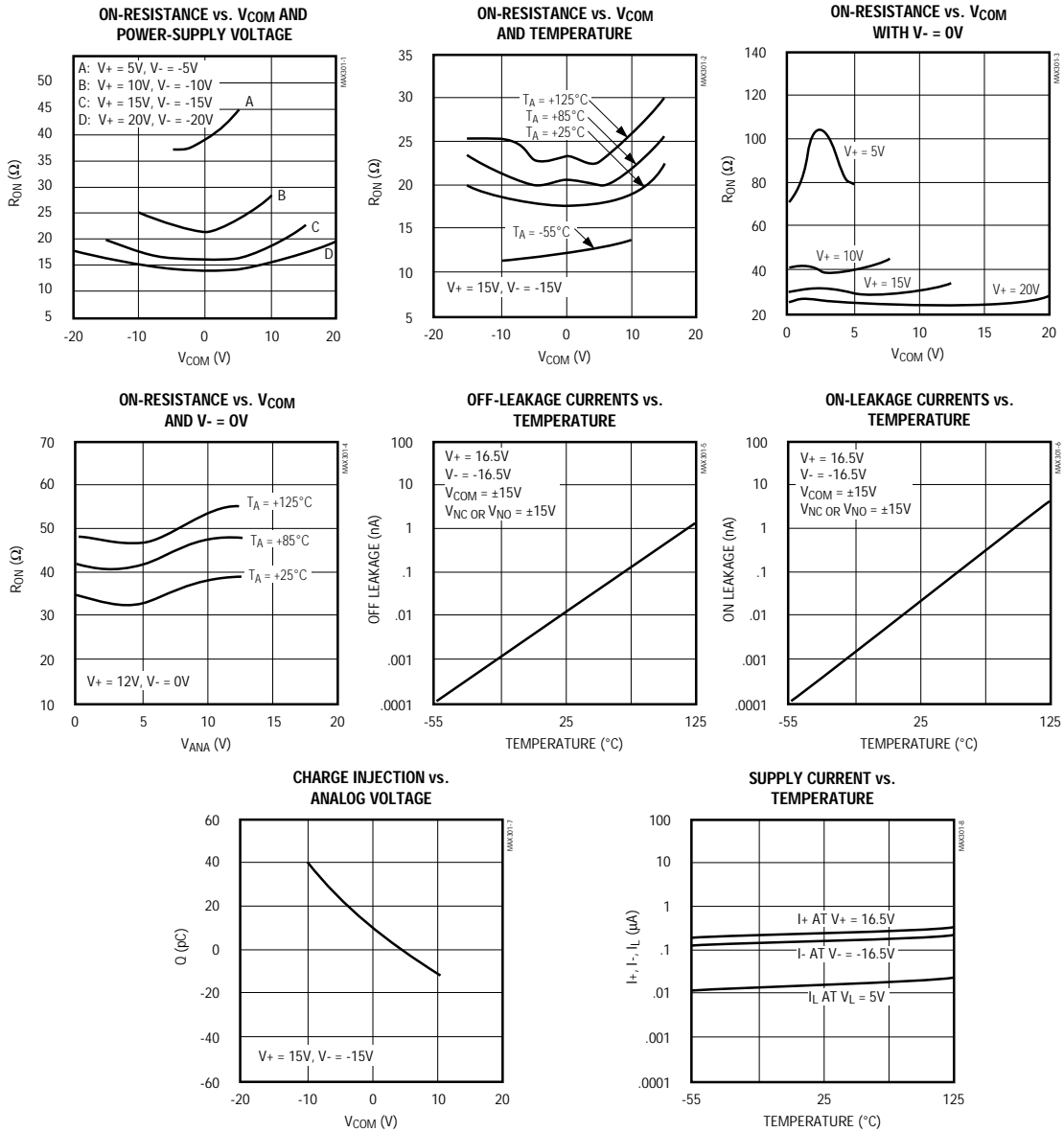

Precision, Dual, High-Speed Analog Switches

MAX301/MAX303/MAX305

Pin Descriptions

MAX301 PIN		NAME	FUNCTION
DIP/SO	LCC		
1, 8	2, 10	COM1, COM2	Drain (Analog Signal)
2-7	1, 3-9, 11, 16	N.C.	Not internally connected
9, 16	5, 7, 12, 20	NC1, NC2	Source (Analog Signal)
10, 15	13, 19	IN2, IN1	Digital Logic Inputs
11	14	V+	Positive Supply-Voltage Input—connected to substrate
12	15	V _L	Logic Supply-Voltage Input
13	17	GND	Ground
14	18	V-	Negative Supply Voltage Input
MAX303 PIN		NAME	FUNCTION
DIP/SO	LCC		
1, 8, 3, 6	2, 4, 8, 10	COM ₋	Drain (Analog Signal)
2-7	1, 3, 6, 9, 11, 16	N.C.	Not internally connected
11	14	V+	Positive Supply-Voltage Input—connected to substrate
12	15	V _L	Logic Supply-Voltage Input
13	17	GND	Ground
14	18	V-	Negative Supply Voltage Input
15, 10	19, 13	IN1, IN2	Digital Logic Inputs
16, 9, 5, 4	5, 7, 12, 20	NC ₋ , NO ₋	Source (Analog Signal)
MAX305 PIN		NAME	FUNCTION
DIP/SO	LCC		
1, 8, 3, 6	2, 4, 8, 10	COM ₋	Drain (Analog Signal)
2-7	1, 3, 6, 9, 11, 16	N.C.	Not internally connected
11	14	V+	Positive Supply-Voltage Input—connected to substrate
12	15	V _L	Logic Supply-Voltage Input
13	17	GND	Ground
14	18	V-	Negative Supply Voltage Input
15, 10	19, 13	IN1, IN2	Digital Logic Inputs
16, 9, 5, 4	5, 7, 12, 20	NO ₋	Source (Analog Signal)

Applications Information

Operation with Supply Voltages Other than ±15V

The MAX301/MAX303/MAX305 switches operate with ±4.5V to ±20V bipolar supplies and a +10V to +30V single supply. In either case, analog signals ranging from V₊ to V₋ can be switched. The *Typical Operating Characteristics* graphs show the typical on-resistance variation with analog signal and supply voltage. The usual on-resistance temperature coefficient is 0.5%/°C (typ).

Logic Inputs

The MAX301/MAX303/MAX305 operate with a single positive supply or with bipolar supplies. The devices maintain TTL compatibility with supplies anywhere in the ±4.5V to ±20V range as long as V_L = +5V. If V_L is connected to V₊ or another supply at voltages other than +5V, the devices will operate at CMOS-logic level inputs.

Overvoltage Protection

Proper power-supply sequencing is recommended for all CMOS devices. It is important not to exceed the absolute maximum ratings because stresses beyond the listed ratings may cause permanent damage to the devices. Always sequence V₊ on first, followed by V_L, V₋, and logic inputs. If power-supply sequencing is not possible, add two small signal diodes in series with the supply pins for overvoltage protection (Figure 1). Adding diodes reduces the analog signal range to 1V below V₊ and 1V below V₋, but low switch resistance and low leakage characteristics are unaffected. Device operation is unchanged, and the difference between V₊ to V₋ should not exceed +44V.

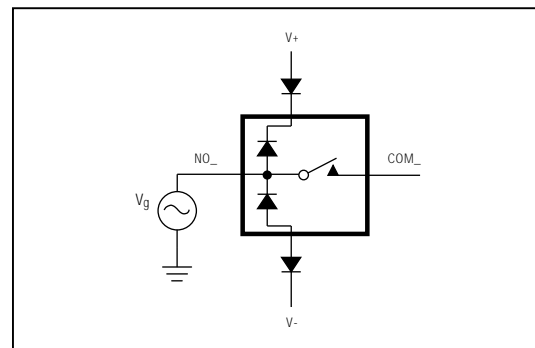

Figure 1. Overvoltage Protection Using Blocking Diodes

Precision, Dual, High-Speed Analog Switches

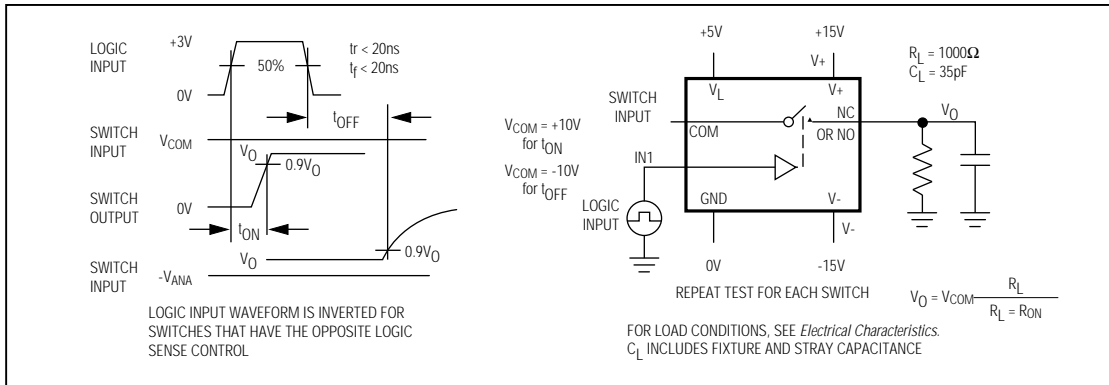

Figure 2. Switching-Time Test Circuit

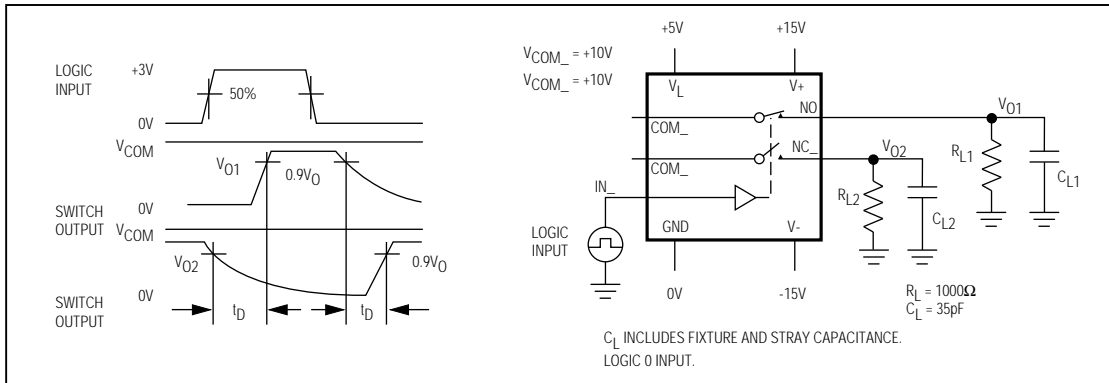

Figure 3. Break-Before-Make Test Circuit

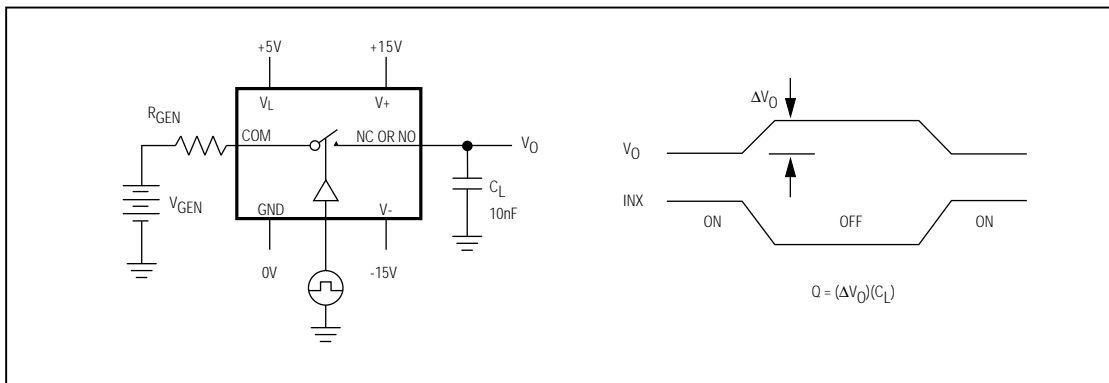

Figure 4. Charge-Injection Test Circuit

Precision, Dual, High-Speed Analog Switches

MAX301/MAX303/MAX305

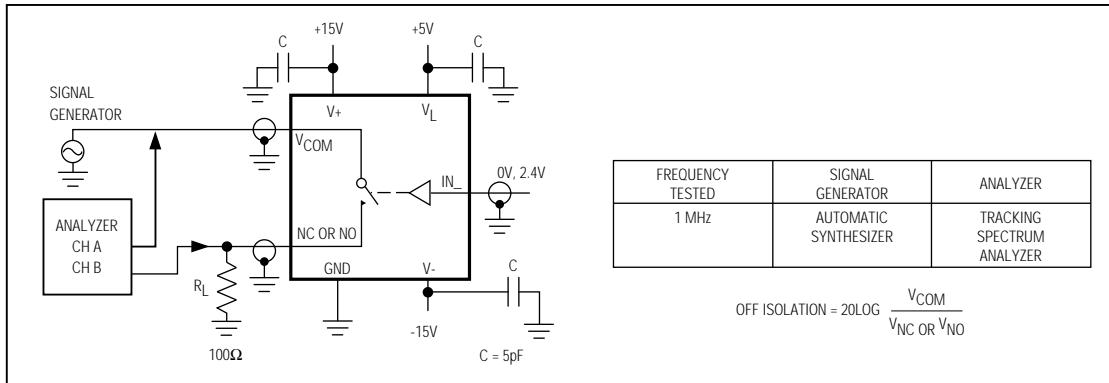

Figure 5. Off Isolation

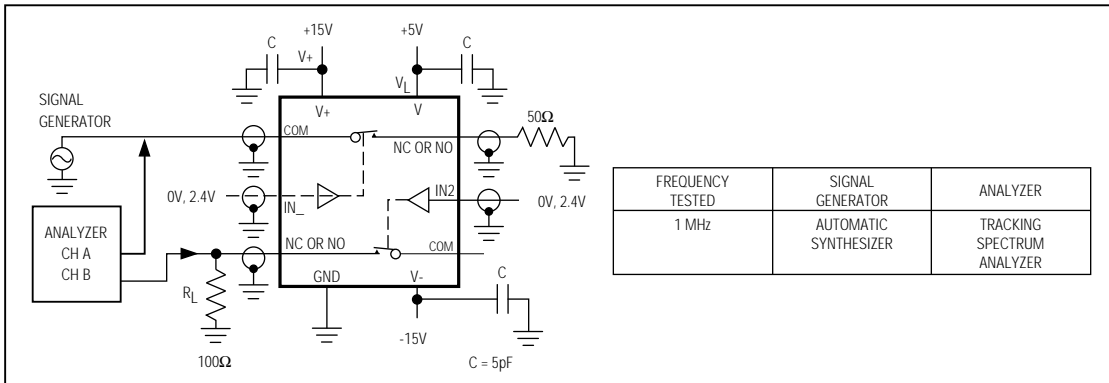

Figure 6. Crosstalk Test Circuit

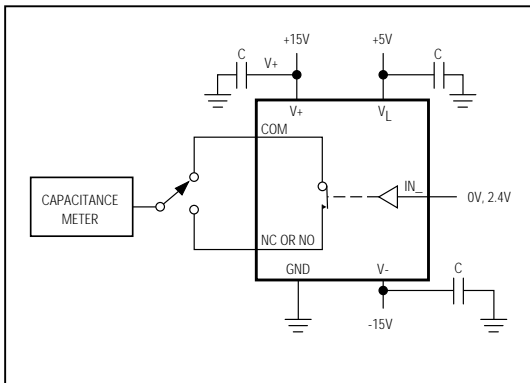

Figure 7. Channel On-Capacitance

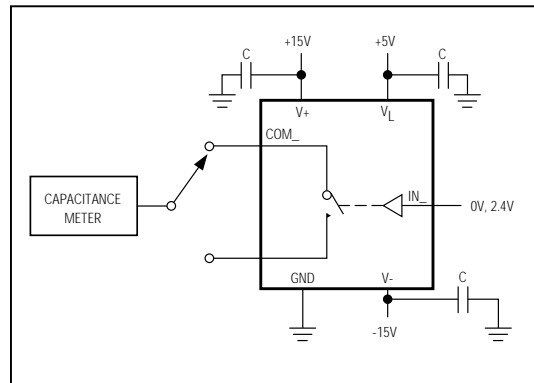

Figure 8. Channel Off-Capacitance

Precision, Dual, High-Speed Analog Switches

MAX301/MAX303/MAX305

Ordering Information (continued)

PART	TEMP RANGE	PIN-PACKAGE	PKG CODE
MAX303CPE	0°C to +70°C	16 Plastic DIP	P16-1
MAX303CSE	0°C to +70°C	16 Narrow SO	S16-2
MAX303CJE	0°C to +70°C	16 CERDIP	J16-3
MAX303C/D	0°C to +70°C	Dice*	—
MAX303EPE	-40°C to +85°C	16 Plastic DIP	P16-1
MAX303ESE	-40°C to +85°C	16 Narrow SO	S16-2
MAX303EJE	-40°C to +85°C	16 CERDIP	J16-3
MAX303MJE	-55°C to +125°C	16 CERDIP	J16-3
MAX303MLP	-55°C to +125°C	20LCC*	L20-3
MAX305CPE	0°C to +70°C	16 Plastic DIP	P16-1
MAX305CSE	0°C to +70°C	16 Narrow SO	S16-2
MAX305CJE	0°C to +70°C	16 CERDIP	J16-3
MAX305C/D	0°C to +70°C	Dice*	—
MAX305EPE	-40°C to +85°C	16 Plastic DIP	P16-1
MAX305ESE	-40°C to +85°C	16 Narrow SO	S16-2
MAX305EJE	-40°C to +85°C	16 CERDIP	J16-3
MAX305MJE	-55°C to +125°C	16 CERDIP	J16-3
MAX305MLP	-55°C to +125°C	20LCC*	L20-3

* Dice are tested at $T_A = +25^\circ\text{C}$ only.

** Contact factory for availability.

Pin Configurations (continued)

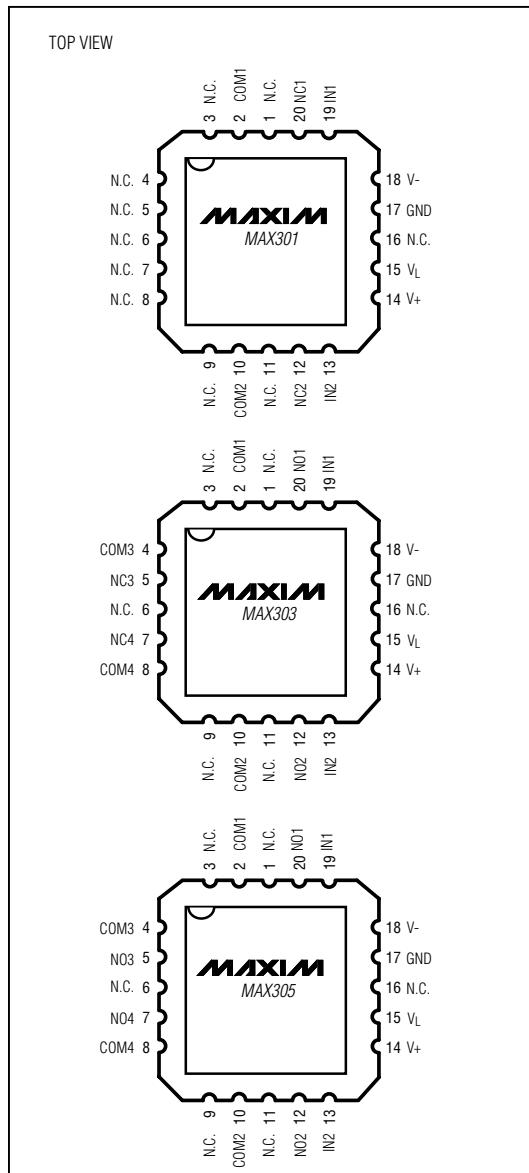

Revision History

Pages changed at Rev 1: 1, 7, 8

Maxim cannot assume responsibility for use of any circuitry other than circuitry entirely embodied in a Maxim product. No circuit patent licenses are implied. Maxim reserves the right to change the circuitry and specifications without notice at any time.

8 Maxim Integrated Products, 120 San Gabriel Drive, Sunnyvale, CA 94086 408-737-7600

© 2007 Maxim Integrated Products

MAXIM is a registered trademark of Maxim Integrated Products, Inc.