

# Amphenol-BSI Compact PCI Datasheet



## Amphenol-BSI cPCI Backplanes

Amphenol-BSI's cPCI high performance backplanes are available in both 3U & 6U form factors. All cPCI backplanes are compliant to VITA cPCI specifications. ABSI can customize the cPCI backplane against our customer's specific requirements.

## Amphenol-BSI CPCI backplane order configuration part number table.

The following configuration table provides the part numbering structure applicable to the full range of cPCI backplanes on offer from Amphenol-BSI. We can engage with you on any cPCI backplane requirement that you may have. Please contact us for further details.

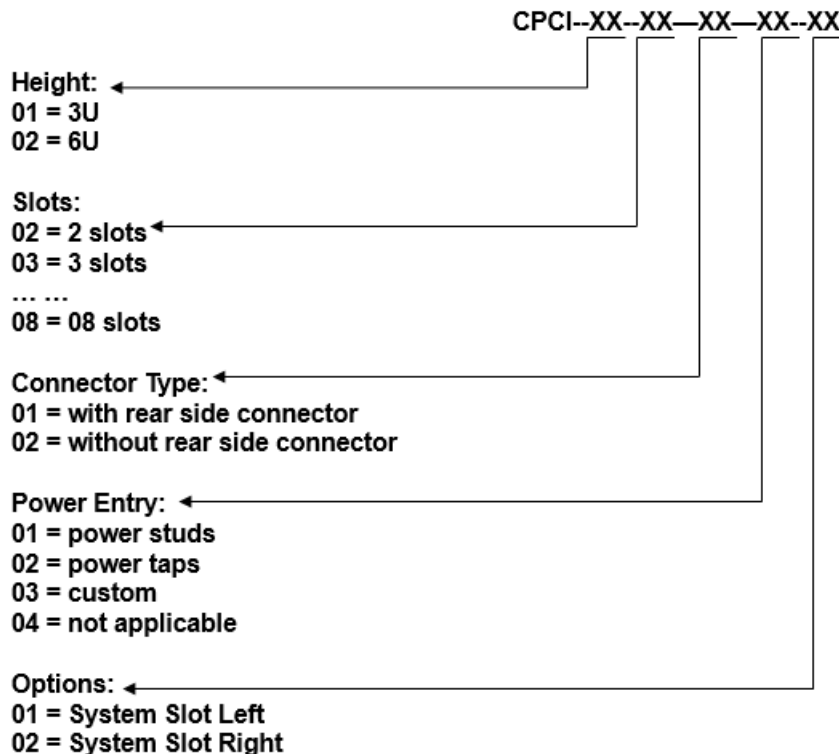

## Configuration part number example

CPCI-02-04-01-02-01 specifies a 6U 4 slot cPCI backplane, configured with RTM connectors and power taps for power entry. The system slot of CPCI-02-04-01-02-01 is at the left most slot.

# Amphenol ABSI Compact PCI Datasheet



## Description

cPCI [Compact Peripheral Component Interface] is electrically identical to the [PCI](#) specification. It uses the Euro ([VME](#)) card 3U/6U format with 2mm connectors. The cPCI bus uses 8, 16, 32, or 64 bit transfers at up to 264MBps. 64 bit PCI transfers may be used in either 3U or 6U size cards. 6U boards contain additional pins for user defined I/O.

cPCI supports live insertion support (Hot-Swap), and also supports two independent buses on the backplane (on different connectors)..

cPCI backplane uses hard metric 2.0mm connectors which are compliant to IEC 917 and IEC 61076-4-101. The maximum slot number is 8 slots. 33MHz bus frequency is available through 2 to 8 slots backplanes. A 66MHz bus frequency is only available on 2 to 5 slots backplanes.

cPCI defines 2 different backplane height 3U and 6U, with or without rear transfer module varieties.

cPCI signal are in all bus topology.

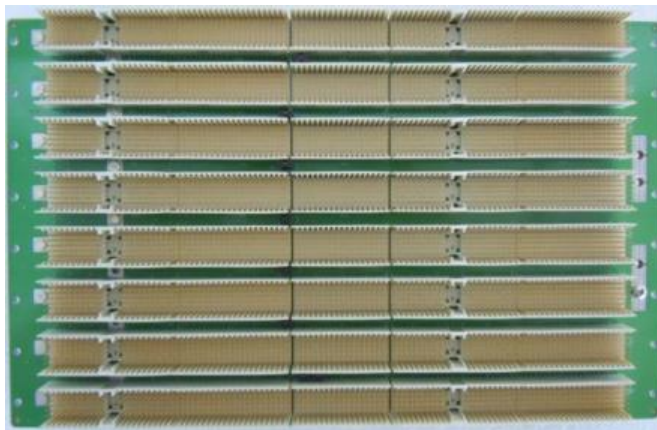

# Amphenol ABSI Compact PCI Datasheet



## Rear side connectors:

The cPCI backplane offers RTM options for all 3U and 6U backplanes. The backplane consists of a long tail pin connector. The picture below represents how a 3U card installs into the backplane slots.

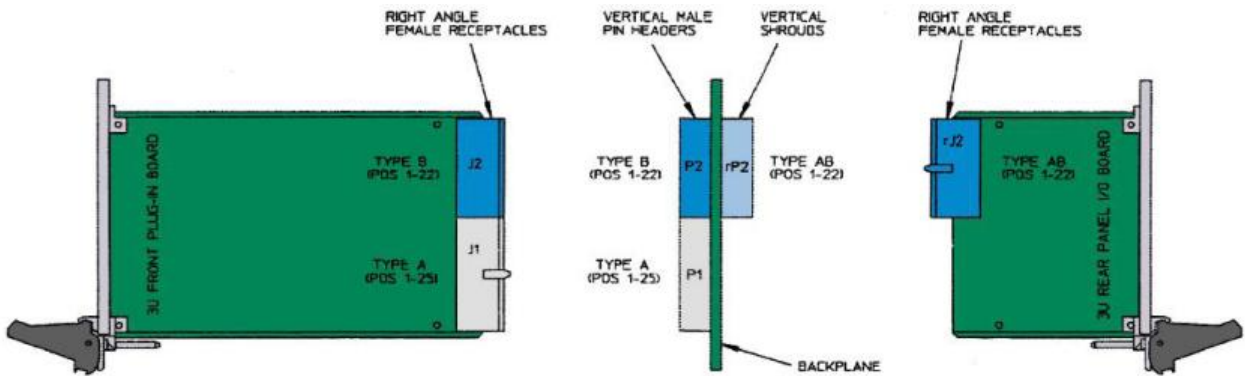

## System slot:

All Amphenol-BSI cPCI backplanes provides marking indication of the system slot and the peripheral slot. The system slot can be customized at the left most or right most of cPCI bus slot.

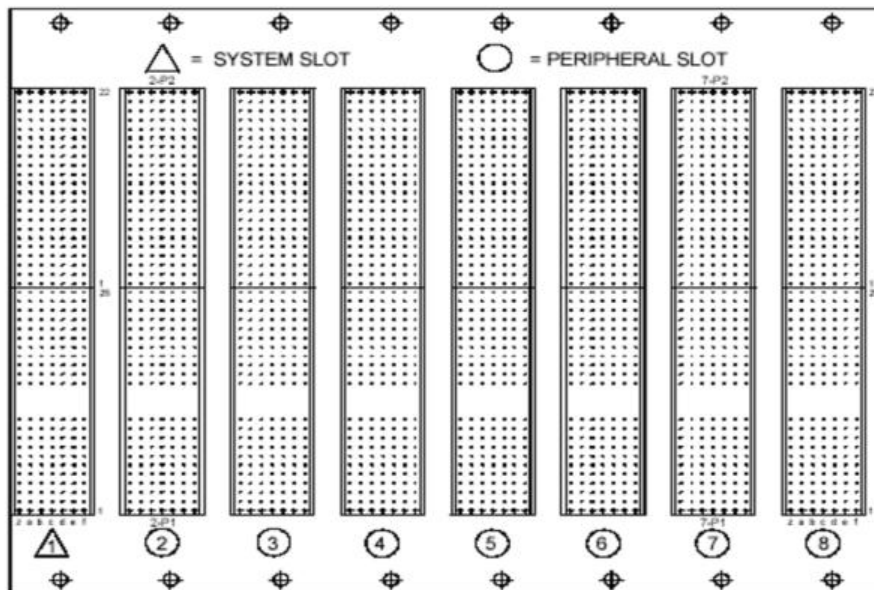

# Amphenol ABSI Compact PCI Datasheet



## Amphenol-BSI cPCI Features:

- Fits within standard 3U/6U Eurocard
- 4 HP slot pitch
- CompactPCI PICMG 2.0 R3.0 compliant
- Hot Swap per PICMG 2.1 R2.0 Spec
- Optional High Availability version
- 32/64 bit bus, 33/66MHz clock
- Left or Right hand system slot
- Rear I/O on P3, P4 & P5 connectors
- 2mm connectors per IEC1076-4-101
- Various power input options
- Connector for SMB-bus, Fans & Auxiliary signals
- Impedance controlled at 65Ω
- Ground guarding for minimal crosstalk
- Dedicated internal power-planes for optimized distribution
- Matched clock skew
- Systems function connector
- Material meets flammability UL94V-0
- RoHS and Halogen-Free

## PCB information:

- 10 layers board
- Slot pitch 0.8"
- Independent power and ground layers for power distribution
- Signal impedance Z0 SE 65 Ohms +/-10%
- FR4 material

# Amphenol ABSI Compact PCI Datasheet



## Connector Type:

The PICMG® standards for CompactPCI provide specifications for hard metric connectors. These shielded connectors have a pitch of 2 mm and are suitable for applications that require high contact density and reliability. Standardization ensures that the connectors are compatible with products from different manufacturers.

Features of cPCI connectors.

- wide selection of types
- modular connectors with a pitch of 2 mm
- 5 or 8 signal rows
- in lengths options
- available with or without shielding
- accessories such as shrouds and coding keys

Connectors are available from Amphenol AICC, ENRI, Harting, TE, ept, etc.



Male connectors for backplanes	Position
Type A Hot Swap	P1
Type A Hot Swap for Midplane	P1
Type B22	P2
Type B22 AB compatible	P2/P5
Type B22 AB compatible	P2/P5
Type B22 AB compatible	P2/P5
Type B19	P3
Type B19 AB compatible	P3
Type B19 AB compatible	P3
Type B19 AB compatible	P3
Type A for telephony	P4
Type A for telephony Midplane	P4
Type A	P4
Type A	P4
Type A	P4
Type B22 for telephony	P5
Type B22 for telephony, Row Z not loaded	P5
Type B22 for telephony, Row Z not loaded	P5

# Amphenol ABSI Compact PCI Datasheet



## Power entry solution

Amphenol-BSI cPCI backplanes have a few power entry solutions to meet our customer's configuration requirements. Choose between power tags, screws or studs as the power input. We also offer industry standard power entry options on cPCI backplanes to meet your power entry requirement.

## Power tags example ERNI 214787:

Press-fit power tags is an option on the cPCI backplane. Each power tap can carry 40A current.



## Power Studs example PEM KFH-632-8-ET

Use of press-fit studs is also an option on cPCI backplane. Each power tap can carry at least 30A current.



## Custom

Our customers can also specify a custom power entry solution that they will use.

# Amphenol ABSI Compact PCI Datasheet



## Amphenol-BSI cPCI Backplane Sizes

### 3U Dimension Table on 0.8" slot pitch,

Slot Numbers	Height in Inch	Height in mm	Length in Inch	Length in mm
2	5.067	128.7	2.360	59.96
3	5.067	128.7	3.160	80.28
4	5.067	128.7	3.960	100.60
5	5.067	128.7	4.760	120.92
6	5.067	128.7	5.560	141.24
7	5.067	128.7	6.360	161.56
8	5.067	128.7	7.160	181.88

### 6U Dimension Table 1.0" slot pitch:

Slot Numbers	Height in Inch	Height in mm	Length in Inch	Length in mm
2	10.317	262.05	2.360	59.96
3	10.317	262.05	3.160	80.28
4	10.317	262.05	3.960	100.60
5	10.317	262.05	4.760	120.92
6	10.317	262.05	5.560	141.24
7	10.317	262.05	6.360	161.56
8	10.317	262.05	7.160	181.88



# Amphenol ABSI Compact PCI Datasheet



## Amphenol-BSI

Amphenol-BSI is an industry leader of backplane and system solutions. Amphenol-BSI has been a leading designer and manufacture of backplanes for more than 30 years.

Amphenol-BSI deliver:

- Industry leading interconnect technology
- Advanced printed circuit capabilities and partnerships
- Innovative backplane system design and manufacturing
- Integrated design / applications engineering services
- Flexible, global support and supply chain management
- Most extensively tooled Backplane Supplier in the industry
- Industry leading Mechanical and SI test solutions
- Lowest cost solution on highest performance backplane