

**SURFACE MOUNT GPP  
TRANSIENT VOLTAGE SUPPRESSOR  
600 WATT PEAK POWER 5.0 WATTS STEADY STATE**

**FEATURES**

- \* Peak pulse power:600 W (10/1000  $\mu$ s),4 kW (8/20  $\mu$ s)
- \* Plastic package has underwriters laboratory
- \* Glass passivated chip construction
- \* 600 watt surge capability at 1ms
- \* Excellent clamping capability
- \* Low zener impedance
- \* Fast response time
- \* MSL:Level 1
- \* P/N suffix V means AEC-Q101 qualified, e.g:SMBJ5.0V
- \* P/N suffix V means Halogen-free

**MECHANICAL DATA**

- \* Epoxy: Device has UL flammability classification 94V-O
- \* UL file No.:E211196

Ratings at 25 °C ambient temperature unless otherwise specified.

**MAXIMUM RATINGS AND ELECTRICAL CHARACTERISTICS**

Ratings at 25 °C ambient temperature unless otherwise specified.



**DO-214AA**

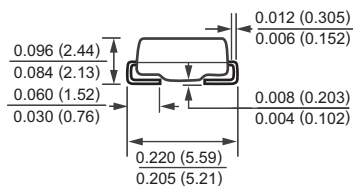
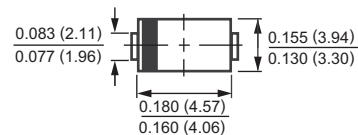

Dimensions in inches and (millimeters)

**DEVICES FOR BIPOLAR APPLICATIONS**

For Bidirectional use C or CA suffix for types SMBJ5.0 thru SMBJ550

Electrical characteristics apply in both direction

**MAXIMUM RATINGS** (At TA = 25°C unless otherwise noted)

RATINGS	SYMBOL	VALUE	UNITS
Peak Power Dissipation with a 10/1000uS (Note 1,2, Fig.1)	PPPM	Minimum 600	Watts
Peak Pulse Current with a 10/1000uS waveform ( Note 1, Fig.3 )	I <sub>PPM</sub>	SEE TABLE 1	Amps
Steady State Power Dissipation at TL = 75°C (Note 2)	P <sub>M(AV)</sub>	5.0	Watts
Peak Forward Surge Current 8.3mS single half sine-wave superimposed on rated load (JEDEC method) (Note 2,3) unidirectional only	I <sub>FSM</sub>	100	Amps
Typical Current Squared Time	I <sup>2</sup> t	41.5	A <sup>2</sup> Sec
Typical Thermal Resistance (Note 1)	R $\theta$ JA	55	°C/W
Typical Thermal Resistance (Note 1)	R $\theta$ JL	5	°C/W
Maximum Instantaneous Forward Voltage at 50A for unidirectional only (Note 3,4)	V <sub>F</sub>	SEE NOTE 5	Volts
Operating and Storage Temperature Range	T <sub>J</sub> , T <sub>STG</sub>	-55 to + 150	°C

- NOTES : 1. Non-repetitive current pulse, per Fig.3 and derated above TA = 25°C per Fig.2.  
 2. Mounted on 0.2 X 0.2" ( 5.0 X 5.0mm ) copper pad to each terminal.  
 3. Lead temperature at TL = 25°C  
 4. Measured on 8.3mS single half sine-wave duty cycle = 4 pulses per minute maximum.  
 5. V<sub>F</sub> = 3.5V on TFMBJ-5.0 thru TFMBJ-90 devices and V<sub>F</sub> = 5.0V on TFMBJ-100 thru TFMBJ-550 devices.  
 6. Thermal Resistance : Mounted on PCB.

2023-02/31  
REV:G

## RATING AND CHARACTERISTIC CURVES ( SMBJ5.0 THRU SMBJ550CA )



## RATING AND CHARACTERISTIC CURVES ( SMBJ5.0 THRU SMBJ550CA )

FIG. 7 - RELATIVE VARIATION OF THERMAL IMPEDANCE  
JUNCTION TO AMBIENT VERSUS PULSE DURATION

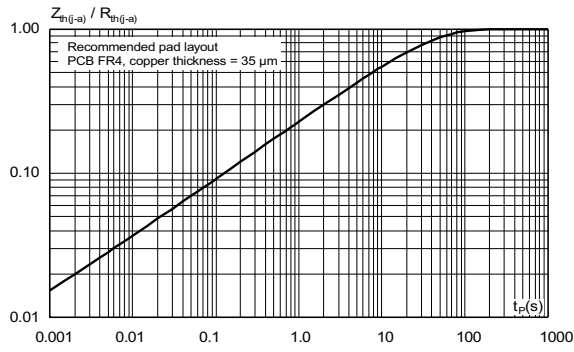

## TRANSIENT VOLTAGE SUPPRESSORS

600W SERIES TVS DIODES / DO-214AA ( CASE 3 ) 600W

Rectron Industry No.	Rectron House No.	Breakdown Voltage			Reverse Stand off Voltage VWM (Volts)	Maximum Reverse Leakage at VWM ID(uA)	Maximum Peak Pulse Current IPPM (Amps)	Maximum Clamping Voltage at IPPM VC (Volts)
		VBR (Volts)		@IT (mA)				
		MIN.	MAX.					
SMBJ5.0	TFMBJ5.0	6.40	7.82	10	5.0	800.0	62.5	9.6
SMBJ5.0A	TFMBJ5.0A	6.40	7.07	10	5.0	800.0	65.2	9.2
SMBJ6.0	TFMBJ6.0	6.67	8.15	10	6.0	800.0	52.6	11.4
SMBJ6.0A	TFMBJ6.0A	6.67	7.37	10	6.0	800.0	58.3	10.3
SMBJ6.5	TFMBJ6.5	7.22	8.82	10	6.5	500.0	48.8	12.3
SMBJ6.5A	TFMBJ6.5A	7.22	7.98	10	6.5	500.0	53.6	11.2
SMBJ7.0	TFMBJ7.0	7.78	9.51	10	7.0	200.0	45.1	13.3
SMBJ7.0A	TFMBJ7.0A	7.78	8.60	10	7.0	200.0	50.0	12.0
SMBJ7.5	TFMBJ7.5	8.33	10.2	1.0	7.5	100.0	42.0	14.3
SMBJ7.5A	TFMBJ7.5A	8.33	9.21	1.0	7.5	100.0	46.5	12.9
SMBJ8.0	TFMBJ8.0	8.89	10.9	1.0	8.0	50.0	40.0	15.0
SMBJ8.0A	TFMBJ8.0A	8.89	9.83	1.0	8.0	50.0	44.1	13.6
SMBJ8.5	TFMBJ8.5	9.44	11.5	1.0	8.5	20.0	37.7	15.9
SMBJ8.5A	TFMBJ8.5A	9.44	10.4	1.0	8.5	20.0	41.7	14.4
SMBJ9.0	TFMBJ9.0	10.0	12.2	1.0	9.0	10.0	35.5	16.9
SMBJ9.0A	TFMBJ9.0A	10.0	11.1	1.0	9.0	10.0	39.0	15.4
SMBJ10	TFMBJ10	11.1	13.6	1.0	10.0	5.0	31.9	18.8
SMBJ10A	TFMBJ10A	11.1	12.3	1.0	10.0	5.0	35.3	17.0
SMBJ11	TFMBJ11	12.2	14.9	1.0	11.0	1.0	29.9	20.1
SMBJ11A	TFMBJ11A	12.2	13.5	1.0	11.0	1.0	33.0	18.2
SMBJ12	TFMBJ12	13.3	16.3	1.0	12.0	1.0	27.3	22.0
SMBJ12A	TFMBJ12A	13.3	14.7	1.0	12.0	1.0	30.2	19.9
SMBJ13	TFMBJ13	14.4	17.6	1.0	13.0	1.0	25.2	23.8
SMBJ13A	TFMBJ13A	14.4	15.9	1.0	13.0	1.0	27.9	21.5
SMBJ14	TFMBJ14	15.6	19.1	1.0	14.0	1.0	23.3	25.8
SMBJ14A	TFMBJ14A	15.6	17.2	1.0	14.0	1.0	25.9	23.2
SMBJ15	TFMBJ15	16.7	20.4	1.0	15.0	1.0	22.3	26.9
SMBJ15A	TFMBJ15A	16.7	18.5	1.0	15.0	1.0	24.6	24.4
SMBJ16	TFMBJ16	17.8	21.8	1.0	16.0	1.0	20.8	28.8
SMBJ16A	TFMBJ16A	17.8	19.7	1.0	16.0	1.0	23.1	26.0
SMBJ17	TFMBJ17	18.9	23.1	1.0	17.0	1.0	19.7	30.5
SMBJ17A	TFMBJ17A	18.9	20.9	1.0	17.0	1.0	21.7	27.6
SMBJ18	TFMBJ18	20.0	24.4	1.0	18.0	1.0	18.6	32.2
SMBJ18A	TFMBJ18A	20.0	22.1	1.0	18.0	1.0	20.5	29.2
SMBJ20	TFMBJ20	22.2	27.1	1.0	20.0	1.0	16.8	35.8
SMBJ20A	TFMBJ20A	22.2	24.5	1.0	20.0	1.0	18.5	32.4
SMBJ22	TFMBJ22	24.4	29.8	1.0	22.0	1.0	15.2	39.4
SMBJ22A	TFMBJ22A	24.4	26.9	1.0	22.0	1.0	16.9	35.5
SMBJ24	TFMBJ24	26.7	32.6	1.0	24.0	1.0	14.0	43.0
SMBJ24A	TFMBJ24A	26.7	29.5	1.0	24.0	1.0	15.4	38.9
SMBJ26	TFMBJ26	28.9	35.3	1.0	26.0	1.0	12.9	46.6
SMBJ26A	TFMBJ26A	28.9	31.9	1.0	26.0	1.0	14.3	42.1
SMBJ28	TFMBJ28	31.1	38.0	1.0	28.0	1.0	12.0	50.0
SMBJ28A	TFMBJ28A	31.1	34.4	1.0	28.0	1.0	13.2	45.4
SMBJ30	TFMBJ30	33.3	40.7	1.0	30.0	1.0	11.2	53.5
SMBJ30A	TFMBJ30A	33.3	36.8	1.0	30.0	1.0	12.4	48.4
SMBJ33	TFMBJ33	36.7	44.9	1.0	33.0	1.0	10.2	59.0
SMBJ33A	TFMBJ33A	36.7	40.6	1.0	33.0	1.0	11.3	53.3
SMBJ36	TFMBJ36	40.0	48.9	1.0	36.0	1.0	9.3	64.3
SMBJ36A	TFMBJ36A	40.0	44.2	1.0	36.0	1.0	10.3	58.1



## TRANSIENT VOLTAGE SUPPRESSORS

600W SERIES TVS DIODES / DO-214AA ( CASE 3 ) 600W

Rectron Industry No.	Rectron House No.	Breakdown Voltage			Reverse Stand off Voltage VWM (Volts)	Maximum Reverse Leakage at VWM ID(uA)	Maximum Peak Pulse Current IPPM (Amps)	Maximum Clamping Voltage at IPPM VC (Volts)
		VBR (Volts)		@IT (mA)				
		MIN.	MAX.					
SMBJ40	TFMBJ40	44.4	54.3	1.0	40	1.0	8.4	71.4
SMBJ40A	TFMBJ40A	44.4	49.1	1.0	40	1.0	9.3	64.5
SMBJ43	TFMBJ43	47.8	58.4	1.0	43	1.0	7.8	76.7
SMBJ43A	TFMBJ43A	47.8	52.8	1.0	43	1.0	8.6	69.4
SMBJ45	TFMBJ45	50.0	61.1	1.0	45	1.0	7.5	80.3
SMBJ45A	TFMBJ45A	50.0	55.3	1.0	45	1.0	8.3	72.7
SMBJ48	TFMBJ48	53.3	65.1	1.0	48	1.0	7.0	85.5
SMBJ48A	TFMBJ48A	53.3	58.9	1.0	48	1.0	7.8	77.4
SMBJ51	TFMBJ51	56.7	69.3	1.0	51	1.0	6.6	91.1
SMBJ51A	TFMBJ51A	56.7	62.7	1.0	51	1.0	7.3	82.4
SMBJ54	TFMBJ54	60.0	73.3	1.0	54	1.0	6.2	96.3
SMBJ54A	TFMBJ54A	60.0	66.3	1.0	54	1.0	6.9	87.1
SMBJ58	TFMBJ58	64.4	78.7	1.0	58	1.0	5.8	103
SMBJ58A	TFMBJ58A	64.4	71.2	1.0	58	1.0	6.4	93.6
SMBJ60	TFMBJ60	66.7	81.5	1.0	60	1.0	5.6	107
SMBJ60A	TFMBJ60A	66.7	73.7	1.0	60	1.0	6.2	96.8
SMBJ64	TFMBJ64	71.1	86.9	1.0	64	1.0	5.3	114
SMBJ64A	TFMBJ64A	71.1	78.6	1.0	64	1.0	5.8	103
SMBJ70	TFMBJ70	77.8	95.1	1.0	70	1.0	4.8	125
SMBJ70A	TFMBJ70A	77.8	86.0	1.0	70	1.0	5.3	113
SMBJ75	TFMBJ75	83.3	102	1.0	75	1.0	4.5	134
SMBJ75A	TFMBJ75A	83.3	92.1	1.0	75	1.0	5.0	121
SMBJ78	TFMBJ78	86.7	106	1.0	78	1.0	4.3	139
SMBJ78A	TFMBJ78A	86.7	95.8	1.0	78	1.0	4.8	126
SMBJ85	TFMBJ85	94.4	115	1.0	85	1.0	4.0	151
SMBJ85A	TFMBJ85A	94.4	104	1.0	85	1.0	4.4	137
SMBJ90	TFMBJ90	100	122	1.0	90	1.0	3.8	160
SMBJ90A	TFMBJ90A	100	111	1.0	90	1.0	4.1	146
SMBJ100	TFMBJ100	111	136	1.0	100	1.0	3.4	179
SMBJ100A	TFMBJ100A	111	123	1.0	100	1.0	3.7	162
SMBJ110	TFMBJ110	122	149	1.0	110	1.0	3.1	196
SMBJ110A	TFMBJ110A	122	135	1.0	110	1.0	3.4	177
SMBJ120	TFMBJ120	133	163	1.0	120	1.0	2.8	214
SMBJ120A	TFMBJ120A	133	147	1.0	120	1.0	3.1	193
SMBJ130	TFMBJ130	144	176	1.0	130	1.0	2.6	231
SMBJ130A	TFMBJ130A	144	159	1.0	130	1.0	2.9	209
SMBJ150	TFMBJ150	167	204	1.0	150	1.0	2.2	268
SMBJ150A	TFMBJ150A	167	185	1.0	150	1.0	2.5	243
SMBJ160	TFMBJ160	178	218	1.0	160	1.0	2.1	287
SMBJ160A	TFMBJ160A	178	197	1.0	160	1.0	2.3	259
SMBJ170	TFMBJ170	189	231	1.0	170	1.0	2.0	304
SMBJ170A	TFMBJ170A	189	209	1.0	170	1.0	2.2	275

- Notes :
1. VBR measured after IT applied for 300ms. IT = square pulse or equivalent.
  2. For bidirectional use C or CA suffixs for all types (ex. SMBJ5.0C,SMBJ170CA) electrical characteristics apply in both directions.
  3. For bidirectional types having VWM of 10 volts and less, the ID limit is doubled.
  4. All devices UL listed file# E211196.



## TRANSIENT VOLTAGE SUPPRESSORS

600W SERIES TVS DIODES / DO-214AA ( CASE 3 ) 600W

Rectron Industry No.	Rectron House No.	Breakdown Voltage			Reverse Stand off Voltage $V_{WM}$ (Volts)	Maximum Reverse Leakage at $V_{WM}$ $I_D$ ( $\mu$ A)	Maximum Peak Pulse Current IPPM (Amps)	Maximum Clamping Voltage at IPPM $V_C$ (Volts)
		$V_{BR}$ (Volts)		$@I_T$ (mA)				
		MIN.	MAX.					
SMBJ180A	TFMBJ180A	201	222	1.0	180	1.0	292	
SMBJ190A	TFMBJ190A	209	243	1.0	190	1.0	308	
SMBJ200A	TFMBJ200A	224	247	1.0	200	1.0	324	
SMBJ210A	TFMBJ210A	231	268	1.0	210	1.0	340	
SMBJ220A	TFMBJ220A	246	272	1.0	220	1.0	358	
SMBJ250A	TFMBJ250A	279	309	1.0	250	1.0	405	
SMBJ300A	TFMBJ300A	335	371	1.0	300	1.0	486	
SMBJ350A	TFMBJ350A	391	432	1.0	350	1.0	567	
SMBJ400A	TFMBJ400A	447	494	1.0	400	1.0	648	
SMBJ440A	TFMBJ440A	492	543	1.0	440	1.0	713	
SMBJ480A	TFMBJ480A	536	593	1.0	480	1.0	750	
SMBJ520A	TFMBJ520A	578	640	1.0	520	1.0	762	
SMBJ550A	TFMBJ550A	615	680	1.0	550	1.0	860	

- Notes :
1.  $V_{BR}$  measured after  $I_T$  applied for 300ms.  $I_T$  = square pulse or equivalent.
  2. For bidirectional use C or CA suffixs for all types (ex. SMBJ5.0C,SMBJ170CA) electrical characteristics apply in both directions.
  3. For bidirectional types having  $V_{WM}$  of 10 volts and less, the  $I_D$  limit is doubled.
  4. All devices UL listed file# E211196.



### Mounting Pad Layout



Dimensions in inches and (millimeters)



# REEL TAPING SPECIFICATIONS FOR SURFACE MOUNT DEVICES-FLAT MELF ( SMA/SMB/SMC )



Fig.: Configuration of FLAT MELF TAPING  
( SMA/SMB/SMC )

ITEM	SYMBOL	DO214AC (SMA) mm(inch)	DO214AA (SMB) mm(inch)	DO214AB (SMC) mm(inch)
Carrier width	A	2.6 ± 0.15 (.102 ± .006)	3.65 ± 0.1 (.144 ± .004)	6.0 ± 0.1 (.236 ± .004)
Carrier length	B	5.15 ± 0.15 (.203 ± .006)	5.69 ± 0.1 (.224 ± .004)	8.30 ± 0.1 (.327 ± .004)
Carrier depth	C	2.3 ± 0.15 (.091 ± .006)	2.67 ± 0.1 (.105 ± .004)	2.5 ± 0.1 (.098 ± .004)
Sprocket hole	d	1.5 ± 0.1 (.059 ± .004)	1.5 ± 0.1 (.059 ± .004)	1.5 ± 0.1 (.059 ± .004)
Reel outside diameter	D	178 ± 2.0 (7.0 ± .079)	178 ± 2.0 (7.0 ± .079)	178 ± 2.0 (7.0 ± .079)
Reel inner diameter	D1	50 Min.	50 Min.	50 Min.
Feed hole diameter	D2	13 ± 0.5 (.512 ± .020)	13 ± 0.5 (.512 ± .020)	13 ± 0.5 (.512 ± .020)
Sprocket hole position	E	1.5 ± 0.1 (.059 ± .004)	1.5 ± 0.1 (.059 ± .004)	1.5 ± 0.1 (.059 ± .004)
Punch hole position	F	5.65 ± 0.05 (.222 ± .002)	5.65 ± 0.05 (.222 ± .002)	7.65 ± 0.05 (.301 ± .002)
Punch hole pitch	P	4.0 ± 0.1 (.157 ± .004)	8.0 ± 0.1 (.315 ± .004)	8.0 ± 0.1 (.315 ± .004)
Sprocket hole pitch	P0	4.0 ± 0.1 (.157 ± .004)	4.0 ± 0.1 (.157 ± .004)	4.0 ± 0.1 (.157 ± .004)
Embossment center	P1	2.0 ± 0.1 (.079 ± .004)	2.0 ± 0.1 (.079 ± .004)	4.0 ± 0.1 (.157 ± .004)
Total tape thickness	T	0.30 ± .05 (.012 ± .002)	0.6 Max.	0.6 Max.
Tape width	W	12.0 ± 0.2 (.472 ± .008)	12.0 ± 0.2 (.472 ± .008)	16.0 ± 0.2 (.630 ± .008)
Reel width	W1	16.8 ± 2.0 (.661 ± .079)	16.8 ± 2.0 (.661 ± .079)	24.0 ± 2.0 (.945 ± .079)

Notes: 1.Devices are packed in accordance with EIA standard RS-481-A and specification given above.  
2.Available on 7 inch ( 1500 ct. ) or 13 inch ( 5000 ct. ) diameter reels.



## PACKAGING OF DIODE AND BRIDGE RECTIFIERS

### REEL PACK

PACKAGE	PACKING CODE	EA PER REEL	EA PER INNER BOX	COMPONENT SPACE (mm)	TAPE SPACE (mm)	REEL DIA (mm)	CARTON SIZE (mm)	EA PER CARTON	GROSS WEIGHT(Kg)
SMB	-W/-T	3,000	6,000	---	---	330	360*355*360	48,000	13.90



## Attachment information about SMBJXXX

### 1. Internal Circuit



### 2. Marking on the body

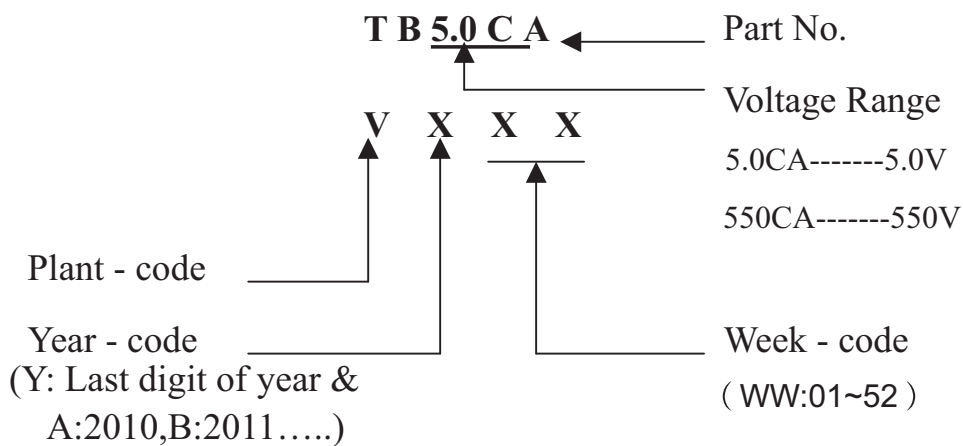
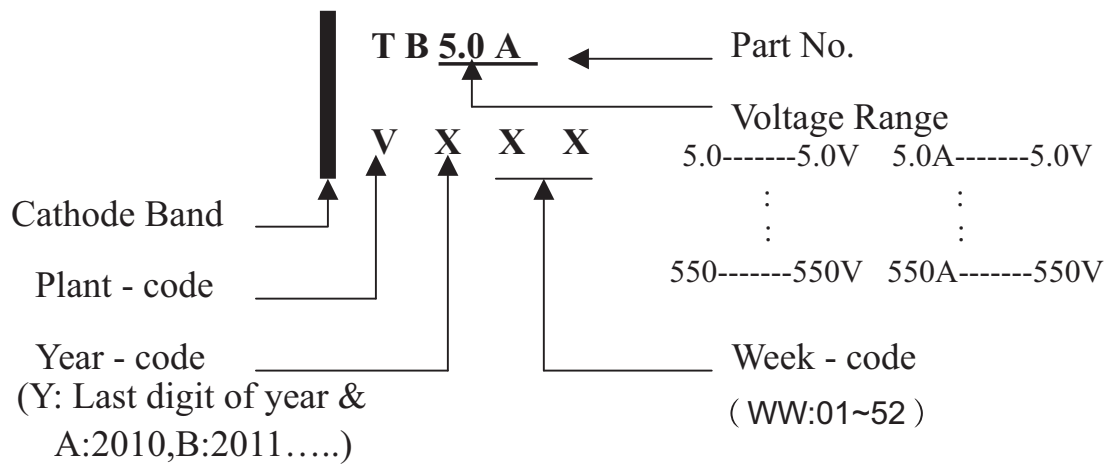

## DISCLAIMER NOTICE

Rectron Inc reserves the right to make changes without notice to any product specification herein, to make corrections, modifications, enhancements or other changes. Rectron Inc or anyone on its behalf assumes no responsibility or liability for any errors or inaccuracies. Data sheet specifications and its information contained are intended to provide a product description only. "Typical" parameters which may be included on RECTRON data sheets and/ or specifications can and do vary in different applications and actual performance may vary over time. Rectron Inc does not assume any liability arising out of the application or use of any product or circuit.

Rectron products are not designed, intended or authorized for use in medical, life-saving implant or other applications intended for life-sustaining or other related applications where a failure or malfunction of component or circuitry may directly or indirectly cause injury or threaten a life without expressed written approval of Rectron Inc. Customers using or selling Rectron components for use in such applications do so at their own risk and shall agree to fully indemnify Rectron Inc and its subsidiaries harmless against all claims, damages and expenditures.

