



LM2791

Current Regulated Switched Capacitor LED Driver with Analog Brightness Control

General Description

The LM2791 is a CMOS charge-pump voltage doubler and regulator that provides two regulated current sources. The LM2791 is designed to drive two white (or blue) LEDs with matched currents (within $\pm 0.3\%$) to produce balanced light sources for display backlights. They accept an input voltage range from 3V to 5.8V and maintain a constant current determined by an external set resistor.

The LM2791 delivers up to 36mA of load current to accommodate two high forward voltage (typically white) LEDs. The switching frequency is 450kHz (min.) to keep the conducted noise spectrum away from sensitive frequencies within portable RF devices.

In the LM2791, brightness is controlled by applying a voltage between GND and 3.0V to the BRGT pin. The LM2791 is available in active high or low shutdown versions. The shutdown pin reduces the operating current to 1 μ A (max.).

The LM2791 is available in a 10 pin leadless leadframe (LLP) CSP package.

Features

- Output matching of $\pm 0.3\%$
- Drives up to two LED's
- 3V to 5.8V Input Voltage
- Up to 36mA output current
- Soft start limits inrush current
- Analog brightness control
- Separate shutdown input
- Very small solution size - no inductor
- 0.7mA typical operating current
- 1 μ A (max.) shutdown current
- 450kHz switching frequency (min.)
- Linear regulation generates predictable noise spectrum
- LLP-10 package: 3mm X 3mm X 0.8mm

Applications

- White LED Display Backlights
- White LED Keypad Backlights
- 1-Cell Li-Ion battery-operated equipment including PDAs, hand-held PCs, cellular phones
- Flat Panel Display

Basic Application Circuit

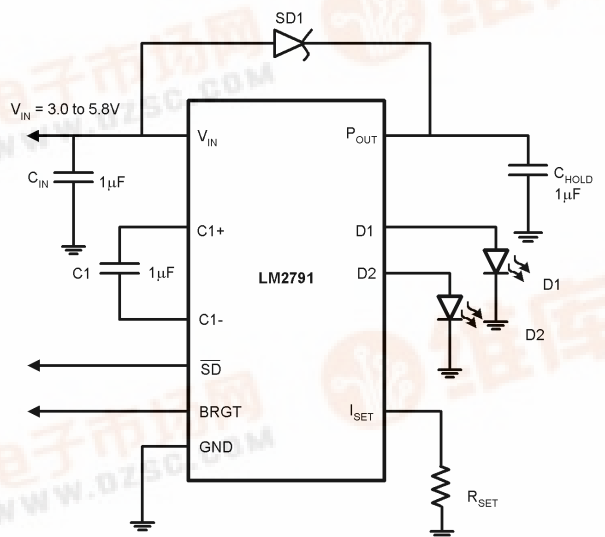

20018301

LM2791 Current Regulated Switched Capacitor LED Driver with Analog Brightness Control



Connection Diagram

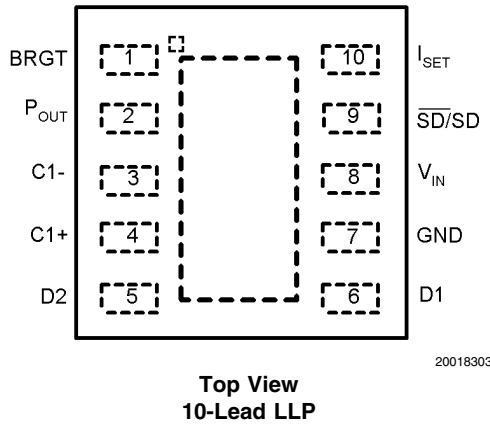

Ordering Information

Order Number	Shutdown Polarity	NSC Package Drawing	Package Marking	Supplied As
LM2791LD-L	Active Low	LLP-10	SNB	1000 Units, Tape and Reel
LM2791LDX-L	Active Low	LLP-10	SNB	4500 Units, Tape and Reel
LM2791LD-H	Active High	LLP-10	SLB	1000 Units, Tape and Reel
LM2791LDX-H	Active High	LLP-10	SLB	4500 Units, Tape and Reel

Pin Description

Pin	Name	Function
1	BRGT	Variable voltage input controls output current.
2	P _{OUT}	Charge pump output.
3	C1-	Connect this pin to the negative terminal of C1.
4	C1+	Connect this pin to the positive terminal of C1.
5	D2	Current source outputs. Connect directly to LED.
6	D1	Current source outputs. Connect directly to LED.
7	GND	Power supply ground input.
8	V _{IN}	Power supply voltage input.
9	SD/ $\overline{\text{SD}}$	Shutdown input. Device operation is inhibited when pin is asserted.
10	I _{SET}	Current Sense Input. Connect resistor to ground to set constant current through LED.

Block Diagram

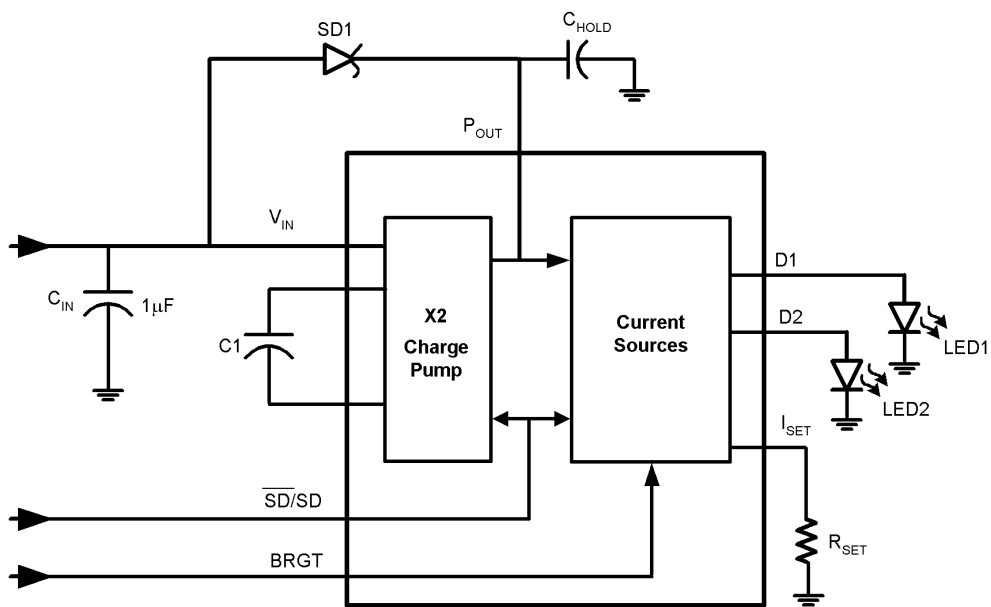

20018302

Absolute Maximum Ratings (Note 1)

If Military/Aerospace specified devices are required, please contact the National Semiconductor Sales Office/ Distributors for availability and specifications.

V_{IN}	-0.3 to 6V
BRGT, SD	-0.3 to ($V_{IN} + 0.2V$)
Power Dissipation (Note 2)	400 mW
T_{JMAX} (Note 2)	150°C
θ_{JA} (Note 7)	55°C/W
Storage Temperature	-65°C to +100°C
Lead Temp. (Soldering, 5 sec.)	260°C

ESD Rating

Human Body Model

2KV

Machine Model

200V

Operating Conditions

Input Voltage (V_{IN})	3.0V to 5.8V
BRGT	0 to 3.0V
Ambient Temperature (T_A)	-30°C to +85°C
Junction Temperature (T_J)	-30°C to +100°C

Electrical Characteristics

Limits in standard typeface are for $T_J = 25^\circ\text{C}$ and limits in **boldface type** apply over the full **Operating Temperature Range**. Unless otherwise specified, $C_1 = C_{IN} = C_{HOLD} = 1 \mu\text{F}$, $V_{IN} = 3.6V$, $V_{DIODE} = 3.6V$, $R_{SET} = 332\Omega$, BRGT pin = 0V.

Symbol	Parameter	Conditions	Min	Typ	Max	Units
I_{DX}	Diode Current at ID1,2	$V_{IN} = 3V$, $R_{SET} = 270\Omega$	16.5	18		mA
	Available Current at Output Dx	$V_{IN} = 3V$		14.5		
		$V_{IN} = 3.3V$	12.8	15.1	17.7	
		$V_{IN} = 3.6V$	13.3	15.7	18.4	
		$V_{IN} = 4.4V$		16.8		
I_{DX}	Load Regulation at Output Dx	$V_{IN} = 3.6V$ $V_{DX} = 3.0V$ $V_{DX} = 4.0V$		16 15.4		mA
I_{DX}	Line Regulation of Dx Output Current	$3.3V \leq V_{IN} \leq 4.4V$ $V_{DX} = 3.6V$		15.7		mA
$I_{D-MATCH}$	Current Matching Between Any Two Outputs	$3.0V \leq V_{IN} \leq 4.4V$ $V_{D1}, V_{D2} = 3.6V$		0.3		%
I_Q	Quiescent Supply Current	$3.0V \leq V_{IN} \leq 4.4V$, Active, No Load Current		0.7	2	mA
I_{SD}	Shutdown Supply Current	$3.0V \leq V_{IN} \leq 5.5V$, Shutdown at 85°C		0.1 0.3	1	μA
V_{IH}	SD Input Logic High	$3.0V \leq V_{IN} \leq 5.5V$, (Note 5)	$0.8V_{IN}$			V
V_{IL}	SD Input Logic Low	$3.0V \leq V_{IN} \leq 5.5V$, (Note 5)			$0.2V_{IN}$	V
$I_{LEAK-SD}$	SD Input Leakage Current	$0V \leq V_{SD} \leq V_{IN}$		0.1		μA
R_{BRGT}	BRGT Input Resistance			250		k Ω
I_{SET}	I_{SET} Pin Output Current			$I_{DX}/25$		mA
f_{SW}	Switching Frequency (Note 4)	$3.0V \leq V_{IN} \leq 4.4V$	450	650	850	kHz
t_{START}	Startup Time (Note 6)	$I_{DX} = 90\%$ steady state		10		μs

Note 1: Absolute maximum ratings indicate limits beyond which damage to the device may occur. Electrical specifications do not apply when operating the device beyond its rated operating conditions.

Note 2: D1 and D2 may be shorted to GND without damage. P_{OUT} may be shorted to GND for 1sec without damage.

Note 3: In the test circuit, all capacitors are 1.0 μF , 0.3 Ω maximum ESR capacitors. Capacitors with higher ESR will increase output resistance, reduce output voltage and efficiency.

Note 4: The output switches operate at one half of the oscillator frequency, $f_{OSC} = 2f_{SW}$.

Note 5: The interanl thresholds of the shutdown bar are set at about 40% of V_{IN} .

Note 6: This electrical specification is guaranteed by design.

Note 7: For more information regarding the LLP package, please refer to National Semiconductor Application note AN1187

Typical Performance Characteristics Unless otherwise specified, $C_1 = C_{IN}$, $C_{HOLD} = 1\mu F$, $V_{IN} = 3.6V$, $V_{DIODE} = 3.6V$, BRGT pin = 0V, $R_{SET} = 330\Omega$

Supply Current at No Load

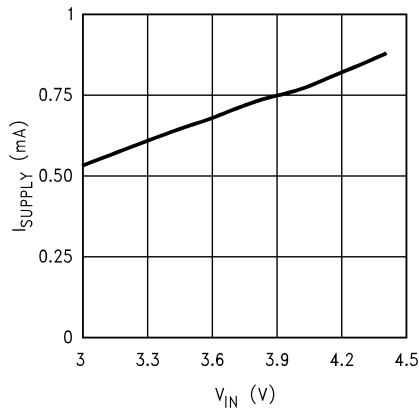

20018305

Supply Current vs Supply Voltage

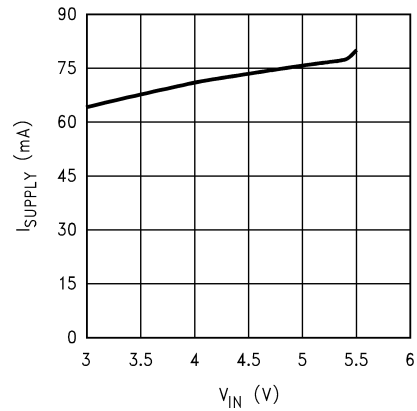

20018312

SD-Threshold

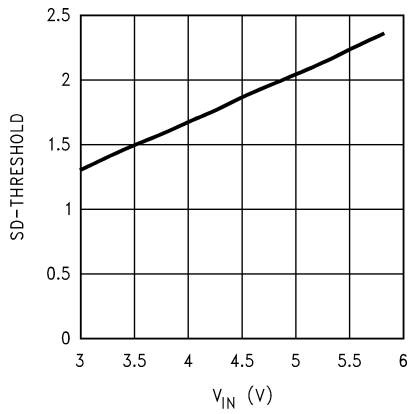

20018308

I_{DIODE} vs V_{DIODE}

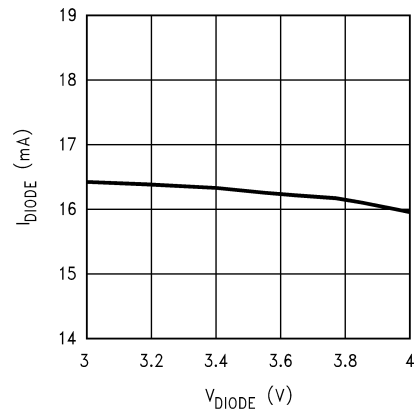

20018310

Diode Current vs. Temperature

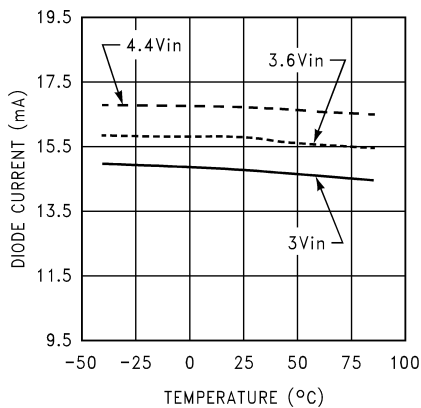

20018320

I_{DIODE} vs R_{Set}

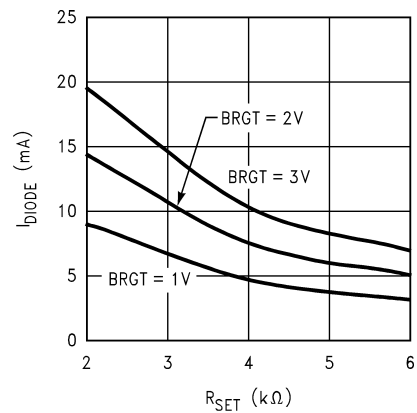

20018311

Typical Performance Characteristics Unless otherwise specified, $C_1 = C_{IN}$, $C_{HOLD} = 1\mu F$, $V_{IN} = 3.6V$, $V_{DIODE} = 3.6V$, BRGT pin = 0V, $R_{SET} = 330\Omega$ (Continued)

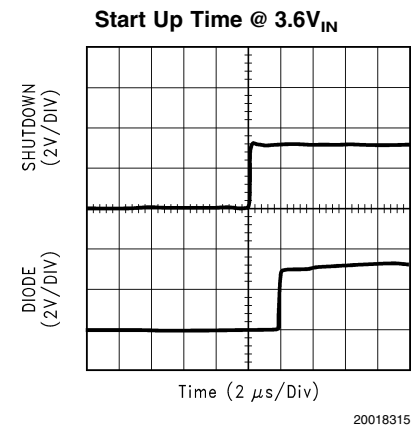
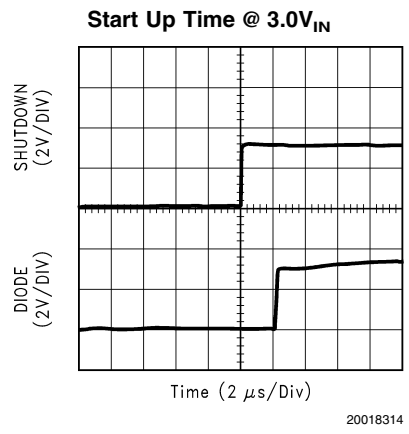
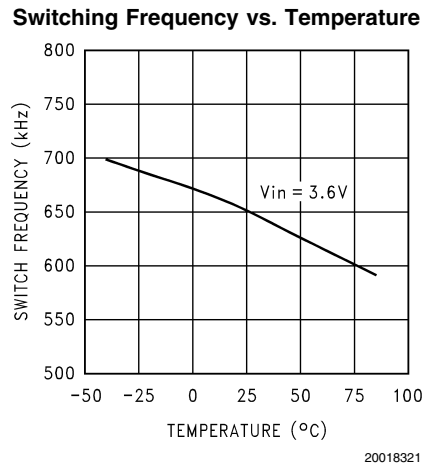
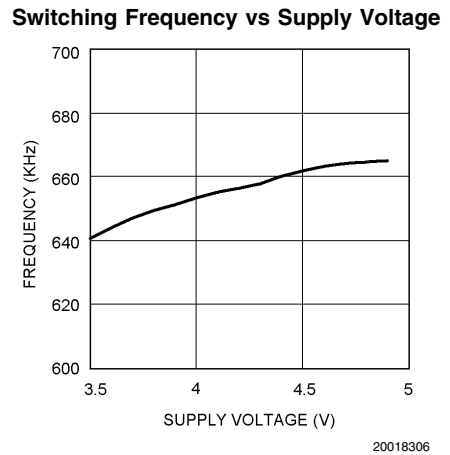
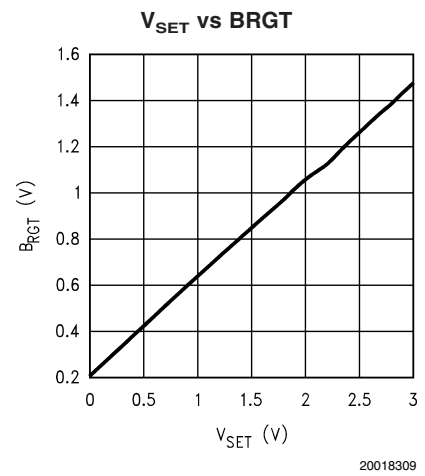
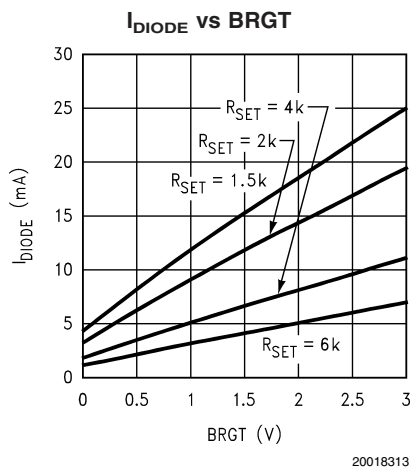

Typical Performance Characteristics Unless otherwise specified, $C_1 = C_{IN}$, $C_{HOLD} = 1\mu F$, $V_{IN} = 3.6V$, $V_{DIODE} = 3.6V$, BRGT pin = 0V, $R_{SET} = 330\Omega$ (Continued)

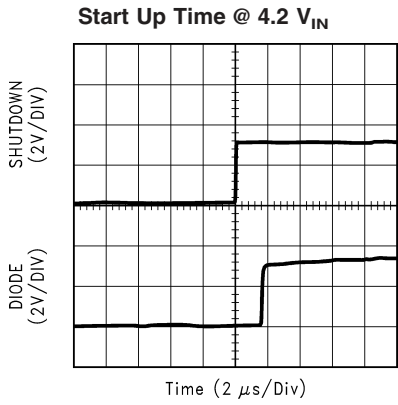

Circuit Description

The LM2791 provides two matched current sources for driving high forward voltage drop LEDs from Li-Ion battery sources. The device has on-chip current regulators which are composed of current mirrors with a 25 to 1 ratio. The mirrors control the LED current without using current limiting resistors in the LED current path. The device can drive up to a total of 36mA through the LEDs.

The LED brightness can be controlled by both analog and or digital methods. The digital technique uses a PWM (Pulse Width Modulation) signal applied to the shutdown input. The analog technique applies an analog voltage to the brightness (BRGT) pin (see Application Information sections). For lowest cost, the LM2791 can be used for constant brightness by grounding BRGT and enabling the shutdown pin.

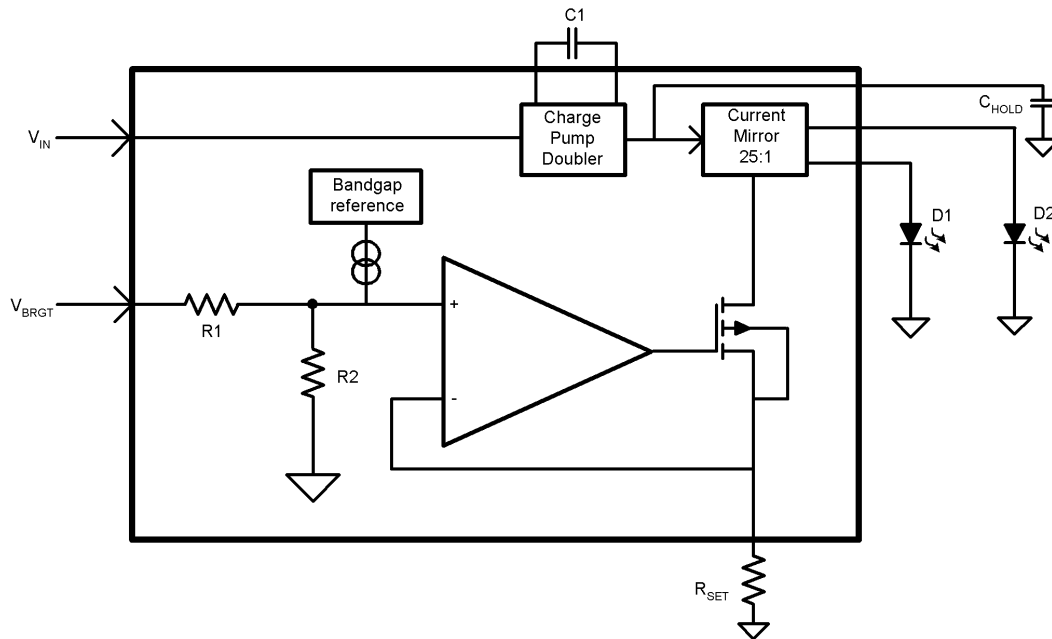

20018304

FIGURE 1.

Application Information

SOFT START

LM2791 includes a soft start function to reduce the inrush currents and high peak current during power up of the device. Soft start is implemented internally by ramping the bandgap more slowly than the applied voltage. This is done by holding the bandgap in shutdown for a short time. During soft start, the switch resistances limit the inrush current used to charge the flying and hold capacitors.

SHUTDOWN MODE

A shutdown pin (SD or /SD) is available to disable the LM2791 and reduce the quiescent current to 1 μ A maximum. The LM2791 is available with both senses of shutdown polarity.

During normal operation mode of the '-L' options, an active high logic signal to the $\overline{\text{SD}}$ pin or tying the $\overline{\text{SD}}$ pin to V_{IN} , will enable the device. Pulling $\overline{\text{SD}}$ low or connecting SD to ground will disable the device.

During normal operation mode of the '-H' options, an active low logic signal to the SD pin or tying the SD pin to GND, will enable the device. Pulling SD high or connecting SD to V_{IN} will disable the device.

CAPACITOR SELECTION

Low equivalent series resistance (ESR) capacitors such as X5R or X7R are recommended to be used for C_{IN} , C1, C2, and C_{HOLD} for best performance. Ceramic capacitors with less than or equal to 0.3 ohms ESR value are recommended for this application. Table 1 below lists suggested capacitor suppliers for the typical application circuit.

TABLE 1. Low ESR Capacitor Manufactures

Manufacturer	Contact	website
TDK	(847) 803 6100	www.component.tdk.com
MuRata	(800) 831 9172	www.murata.com
Taiyo Yuden	(800) 348 2496	www.t-yuden.com

SCHOTTKY DIODE SELECTION

A schottky diode (D1) must be used between V_{IN} and P_{OUT} for proper operation. During start-up, the low voltage drop across this diode is used to charge C_{OUT} and start the oscillator. It is necessary to protect the device from

Application Information (Continued)

turning-on its own parasitic diode and potentially latching-up. As a result, it is important to select a schottky diode that will carry at least 200mA or higher current to charge the output capacitor during start-up. A schottky diode like 1N5817 can be used for most applications or a surface mount diode such as BAT54-series and MA2J704 used to reduce the circuit size. *Table 2* below lists suggested schottky diode manufactures.

TABLE 2. Diode Manufactures

Manufacturer	Contact	Schottky Diodes
ON Semiconductor	(800) 344 3860	www.onsemi.com
Phillips Semiconductors	(800) 234 7381	www.philipssemiconduc tor.com
Panasonic Semiconductor	(408) 945 5622	www.panasonic.com

LED SELECTION

The LM2791 is designed to drive LEDs with a forward voltage of about 3.0V to 4.0V or higher. The typical and maximum V_F depends highly on the manufacturer and their technology. *Table 3* lists two suggested manufactures and example part numbers. Each supplier makes many LEDs that work well with the LM2791. The LEDs suggested below are in a surface mount package and TOPLED or SIDEVIEW configuration with a maximum forward current of 20mA. These diodes also come in SIDELED or SIDEVIEW configuration and various chromaticity groups. For applications that demand color and brightness matching, care must be taken to select LEDs from the same chromaticity group. Forward current matching is assured over the LED process variations due to the constant current output of the LM2791. For best fit selection for an application, consult the manufacturer for detailed information.

TABLE 3. White LED Selection:

Component	Manufacture	Contact
LWT673/LWT67C	Osram	www.osram-os.com
NSCW100/ NSCW215	Nichia	www.nichia.com

I_{SET} PIN

An external resistor, R_{SET} , sets the mirror current that is required to provide a constant current through the LEDs. The current through R_{SET} and the LED is set by the internal

current mirror circuitry with a ratio of 25:1. The currents through each LED are matched within 0.3%. R_{SET} should be chosen not to exceed the maximum current delivery capability of the device. *Table 4* shows a list of R_{SET} values when maximum BRGT = 0V is applied. For other BRGT voltages, R_{SET} can be calculated using this formula:

$$R_{SET} = (((BRGT * 0.42) + V_{OFFSET}) / (I_{LED}) * 25$$

TABLE 4. R_{SET} Selections (when BRGT pin = 0V)

I_{LED} per LED	* R_{SET}
15mA	330 Ω
10mA	500 Ω
5mA	1K

* Use 1% resistor for R_{SET}

Calculation of LED Current When Grounding BRGT:

$$V_{IN} = 3.6V$$

$$V_{OFFSET} = 200mV(\text{Reference Voltage})$$

$$R_{SET} = 330\Omega$$

$$I_{LED} = (V_{OFFSET} / R_{SET}) * 25$$

$$I_{LED} = (200mV / 330) * 25 = 15mA$$

BRGT PIN

The BRGT pin can be used to smoothly vary the brightness of the White LEDs. In the LM2791, current on BRGT is connected to an internal resistor divider which gives a factor 0.42 and summed with an offset voltage from the internal bandgap (200mV). This voltage is fed to the operational amplifier that controls the current through the mirror resistor R_{SET} . The nominal range on BRGT is 0V to 3V. Care must be taken to prevent voltages on BRGT that cause LED current to exceed 36mA. Although this will not cause damage to the IC, it will not meet the guaranteed specifications listed in the Electrical Characteristics.

Table 5 shows the current through each LED for the LM2791 with various BRGT and R_{SET} values.

Calculation of LED Current When BRGT Pin > 0:

$$R_{SET} = 2000\Omega$$

$$BRGT = 2.5V$$

$$V_{OFFSET} = 200mV(\text{Reference Voltage})$$

$$I_{LED} = (((BRGT * 0.42) + V_{OFFSET}) / R_{SET}) * 25$$

$$I_{LED} = (((2.5 * 0.42) + 0.20) / 2000) * 25 = 15.6mA$$

TABLE 5. LED Current When Using BRGT Input (Values Highlighted in Boldface exceeded maximum current range of the device if both LEDs are in use)

R_{SET} (Ω)	1000 Ω	1500 Ω	2000 Ω	2500 Ω
BRGT (V)	I_{LED} (mA)	I_{LED} (mA)	I_{LED} (mA)	I_{LED} (mA)
0.5	10.25	6.84	5.10	4.1
1.0	15.5	10.3	7.75	6.2
1.5	20.75	13.8	10.37	8.3
2.0	26	17.3	13.00	10.4
2.5	31.25	20.80	15.6	12.5
3.0	36.5	24.3	18.3	14.6

Application Information (Continued)

BRIGHTNESS CONTROL USING PWM

Brightness control can be implemented by pulsing a signal at the SD pin. The recommended signal should be between 100Hz to 1kHz. If the operating PWM frequency is much less than 100Hz, flicker may be seen in the LEDs. Likewise, if frequency is much higher, brightness in the LEDs will not be linear. When a PWM signal is used to drive the SD pin of the LM2791, connect BRGT pin to a maximum of GND. R_{SET} value is selected using the above I_{SET} equation as if BRGT pin is used. The brightness is controlled by increasing and decreasing the duty cycle of the PWM. Zero duty cycle will turn off the brightness and a 50% duty cycle waveform produces an average current of 7.5mA if R_{SET} is set to produce a maximum LED current of 15mA. So the LED current varies linearly with the duty cycle.

PARALLEL Dx OUTPUTS FOR INCREASED CURRENT DRIVE

Outputs D1 and D2 may be connected together to drive a single LED. In such a configuration, two parallel current sources of equal value drive the single LED. R_{SET} and V_{BRGT} should be chosen so that the current through each of the outputs is programmed to 50% of the total desired LED current. For example, if 30mA is the desired drive current for the single LED, R_{SET} and V_{BRGT} should be selected so that the current through each of the outputs is 15mA. Connecting the outputs in parallel does not affect internal operation of the LM2791 and has no impact on the Electrical Characteristics and limits previously presented. The available Dx output current, maximum Dx voltage, and all other specifications provided in the Electrical Characteristics table apply to this parallel output configuration, just as they do to the standard 2-LED application circuit.

THERMAL PROTECTION

The LM2791 has internal thermal protection circuitry to disable the charge pump if the junction temperature exceeds 150°C. This feature will protect the device from damage due to excessive power dissipation. The device will recover and operate normally when the junction temperature falls below the maximum operating junction temperature of 100°C. It is important to have good thermal conduction with a proper layout to reduce thermal resistance.

POWER EFFICIENCY

An ideal power efficiency for a voltage doubler switched capacitor converter is given as the output voltage of the doubler over twice the input voltage as follows:

$$\text{Efficiency} = (V_{DIODE} * I_{DIODE}) / (V_{IN} * I_{DIODE} * \text{Gain}) = V_{DIODE} / 2V_{IN}$$

In the case of the LM2791, a more accurate efficiency calculation can be applied as the given formula below.

$$\text{Efficiency} = ((V_{D1} * I_{D1}) + (V_{D2} * I_{D2})) / (I_{SUPPLY} * V_{IN})$$

It is clear that the efficiency will depend on the supply voltage in the above equation. As such, the lower the supply voltage, the higher the efficiency.

POWER DISSIPATION

The maximum allowable power dissipation that this package is capable of handling can be determined as follows:

$$P_{DMax} = (T_{JMax} - T_A) / \theta_{JA}$$

where T_{JMax} is the maximum junction temperature, T_A is the ambient temperature, and θ_{JA} is the junction-to-ambient thermal resistance of the specified package.

The actual power dissipation of the device can be calculated using this equation:

$$P_{Dissipation} = (2V_{IN} - V_{DIODE}) * I_{LOAD}$$

As an example, if V_{IN} in the target application is 4.2V, $V_{DIODE} = 3.0V$ and worst case current consumption is 32mA (16mA for each diode).

$$P_{Dissipation} = ((2 * 4.2) - 3.0) * 0.032 = 173mW$$

Power dissipation must be less than that allowed by the package. Please refer to the Absolute Maximum Rating of the LM2791.

PCB LAYOUT CONSIDERATIONS

The LLP is a leadframe based Chip Scale Package (CSP) with very good thermal properties. This package has an exposed DAP (die attach pad) at the center of the package measuring 2.0mm x 1.2mm. The main advantage of this exposed DAP is to offer lower thermal resistance when it is soldered to the thermal land on the PCB. For PCB layout, National highly recommends a 1:1 ratio between the package and the PCB thermal land. To further enhance thermal conductivity, the PCB thermal land may include vias to a ground plane. For more detailed instructions on mounting LLP packages, please refer to National Semiconductor Application Note AN-1187.

Physical Dimensions inches (millimeters) unless otherwise noted

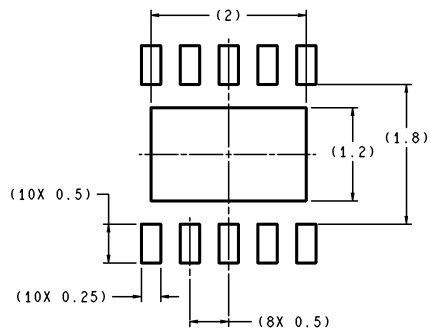

RECOMMENDED LAND PATTERN
1:1 RATION WITH PKG SOLDER PADS

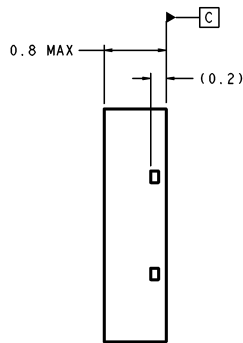
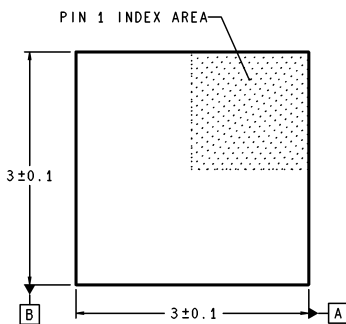

DIMENSIONS ARE IN MILLIMETERS

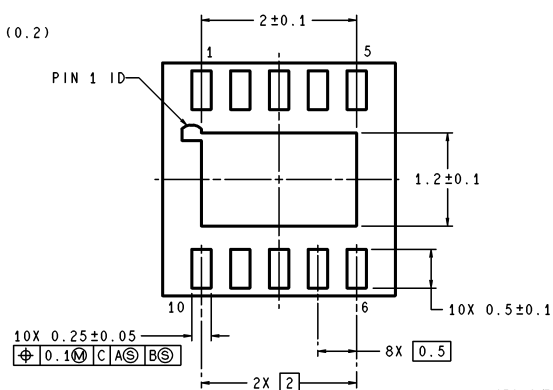

LDA10A (Rev A)

LLP-10 Pin Package (LDA)
For Ordering, Refer to Ordering Information Table
NS Package Number LDA10A

LIFE SUPPORT POLICY

NATIONAL'S PRODUCTS ARE NOT AUTHORIZED FOR USE AS CRITICAL COMPONENTS IN LIFE SUPPORT DEVICES OR SYSTEMS WITHOUT THE EXPRESS WRITTEN APPROVAL OF THE PRESIDENT AND GENERAL COUNSEL OF NATIONAL SEMICONDUCTOR CORPORATION. As used herein:

1. Life support devices or systems are devices or systems which, (a) are intended for surgical implant into the body, or (b) support or sustain life, and whose failure to perform when properly used in accordance with instructions for use provided in the labeling, can be reasonably expected to result in a significant injury to the user.
2. A critical component is any component of a life support device or system whose failure to perform can be reasonably expected to cause the failure of the life support device or system, or to affect its safety or effectiveness.



National Semiconductor Corporation
Americas
Email: support@nsc.com

www.national.com

National Semiconductor Europe

Fax: +49 (0) 180-530 85 86
Email: europe.support@nsc.com
Deutsch Tel: +49 (0) 69 9508 6208
English Tel: +44 (0) 870 24 0 2171
Français Tel: +33 (0) 1 41 91 8790

National Semiconductor Asia Pacific Customer Response Group

Tel: 65-2544466
Fax: 65-2504466
Email: ap.support@nsc.com

National Semiconductor Japan Ltd.

Tel: 81-3-5639-7560
Fax: 81-3-5639-7507